

DRAWING NO:
255250A63I2BAAAA

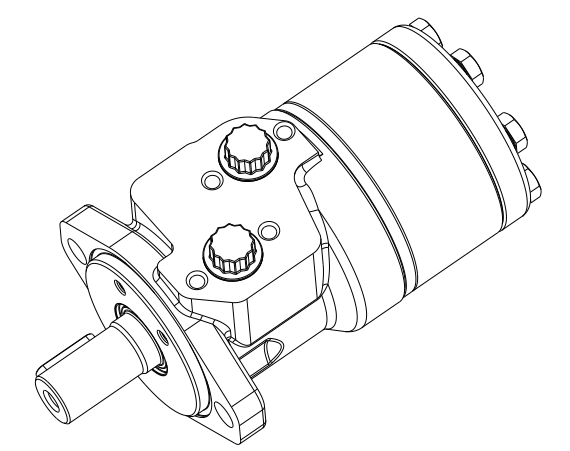

MODEL SPECIFICATIONS

| | |
|---|---------------------|
| Displacement - cm ³ [in ³] | 250 [15.3] |
| Max. Speed - rpm | |
| Continuous | 250 |
| Intermittent | 300 |
| Max. Flow - lpm [gpm] | |
| Continuous | 61 [16] |
| Intermittent | 76 [20] |
| Max. Torque - Nm [lb-in] | |
| Continuous | 561 [4965] |
| Intermittent | 624 [5522] |
| Max. Pressure - bar [psi] | |
| Continuous | 172 [2500] |
| Intermittent | 207 [3000] |
| peak | 224 [3250] |
| Check Valve | Yes |
| Intermittent operation | 10% of every minute |
| Peak operation | 1% of every minute |

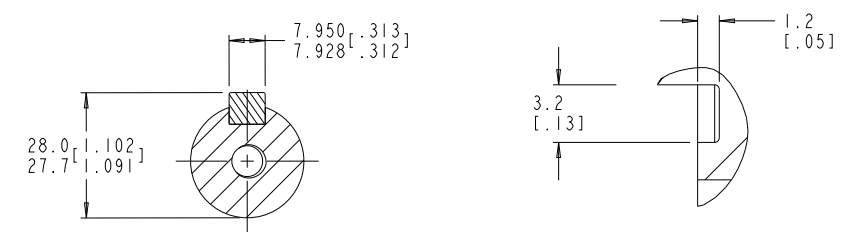
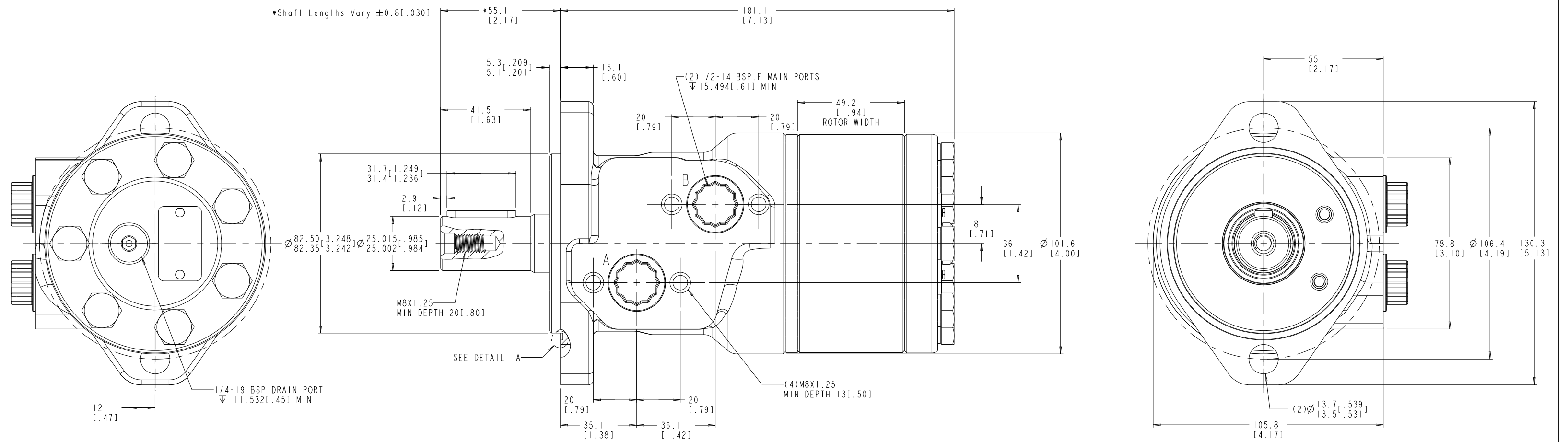