

KRV RELIEF VALVES

KRV series modular relief valves can control flow for positive direction pass oil port. Flow can be adjusted by handle. It passes to check valve for reverse flow.

Technical characteristics

Size	6	10	16
Max. Flow (L/min)	35	70	120
Max. W.P (Mpa)	31.5		
Working fluid	mineral oil ; phosphate-ester		
Fluid temperature (°C)	-20~70		
Viscosity (mm ² /s)	12~380		

Ordering code

KRV-06-P-1-3

Modular relief Valve

NOMINAL SIZE: 06 Cetop 3 10 Cetop 5 16 cetop 7

P P Pipeline relief **A** A Pipeline relief

B B Pipeline relief **W** AB Pipeline relief

Adjustment type: 1:rotatory knob 2: sleeve with exagon

Setting pressure 5 to 50Mpa 1 to 10Mpa 2 to 20Mpa 3 to 31.5Mpa

Code symbol

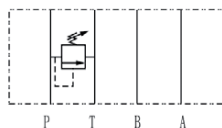

KRV-P

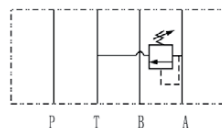

KRV-A

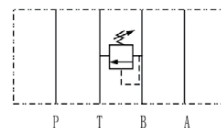

KRV-B

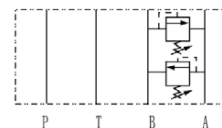

KRV-W

KRV RELIEF VALVES

Dimensions

KRV-06-A

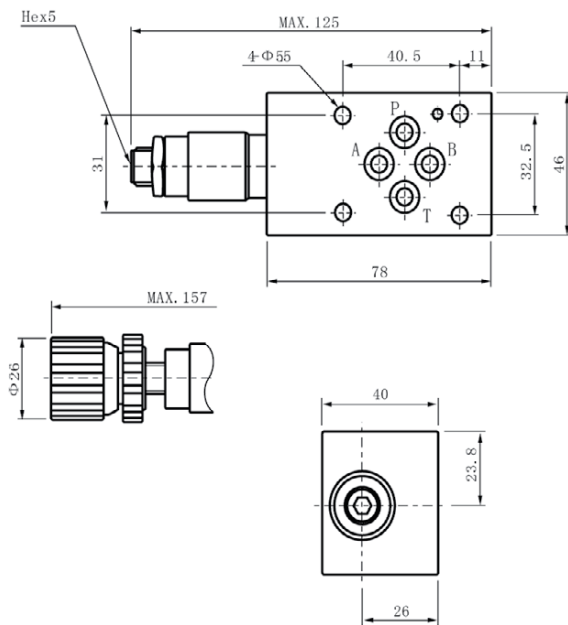

KRV-06-B/P

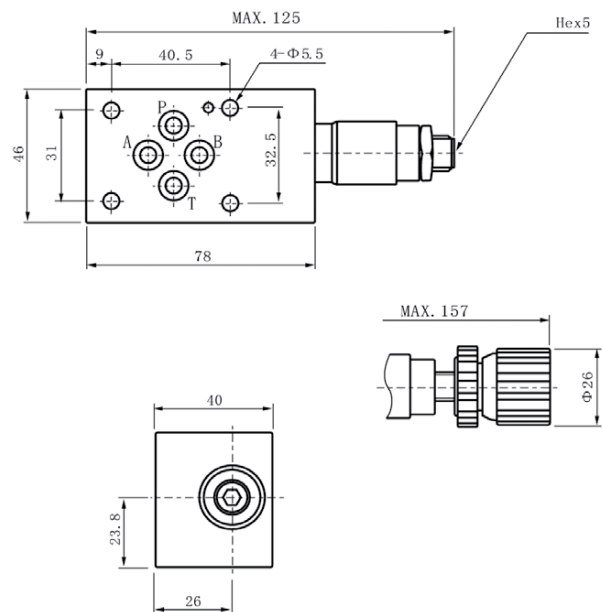

KRV-06-W

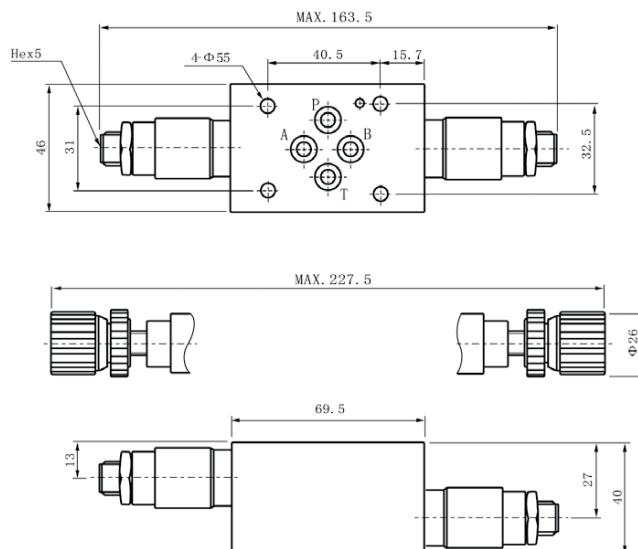

KRV-10-A

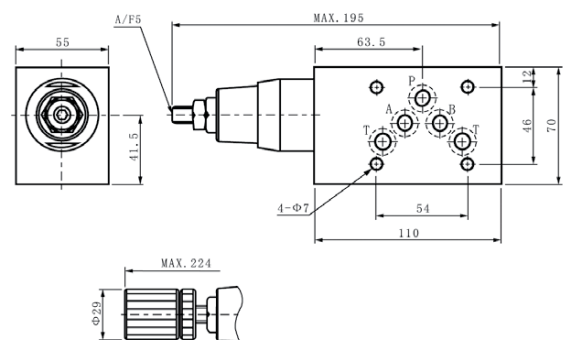

KRV RELIEF VALVES

Dimensions

KRV-10-B/P

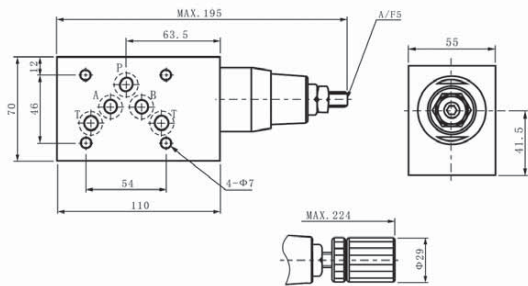

KRV-10-W

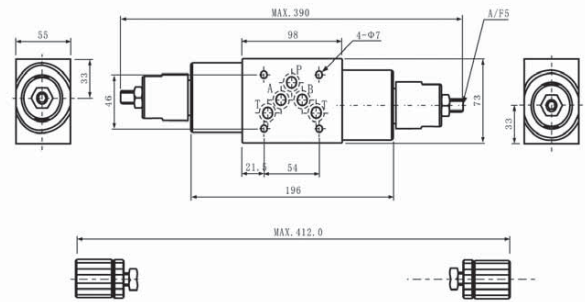

KRV-16-P

