

# ANELLO DI ESTRAZIONE E CENTRAGGIO POMPA CENTERING AND EXTRACTION RING

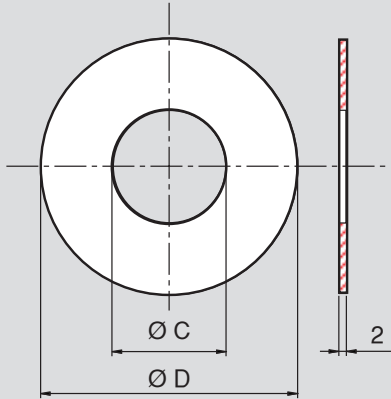

LANTERNA BELL HOUSING	ANELLO DI CENTRAGGIO CENTERING RING	DIMENSIONI DIMENSIONS		POMPA / PUMP
		Ø D	Ø C	
140 M - 160 M 200 M - 250 M	A1 254	67,5	25,4	1CA - 1UN
	A1 300	67,5	30	1MA
	A1 365	67,5	36,5	2UN
200 C - 250 C 300 M	A2 365	88	36,5	2UN
	A2 508	88	50,8	25T - 3MA - 3TS - 3UN
	A2 600	88	60	35M
	A2 603	88	60,3	35G - 35U
	A3 508	110	50,8	25T - 3MA - 3TS - 3UN
350 M	A3 600	110	60	35M
	A3 603	110	60,3	35G - 35U
	A3 635	110	63,5	4UN - 4TS - 4MA

## PIEDINI - FOOT FLANGE

Fig. A

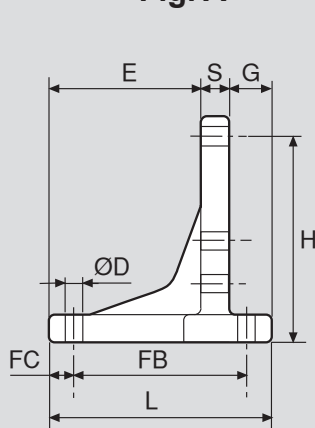
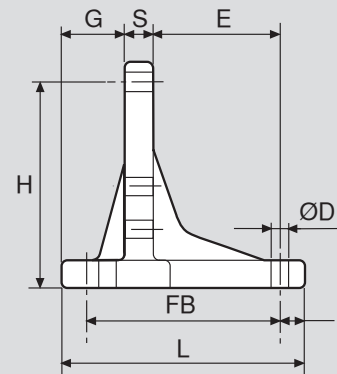
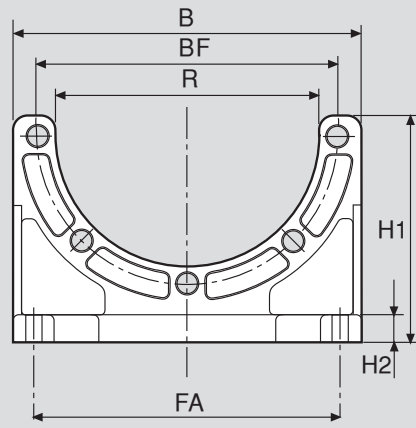

Fig. B



GRANDEZZA MOTORE MOTOR SIZE	PIEDINO FOOT FLANGE	FIG.	DIMENSIONI / DIMENSIONS														LANTERNA BELL HOUSING
			B	BF	R	FA	FB	FC	L	D	E	S	G	H	H1	H2	
71	BB 160	A	160	130	115	135	80	10	100	9	68	12	20	100	112	12	160
80 - 90	BB 200	A	200	165	140	176	103	13	128	11	88	15	25	123	138	15	200
100 - 112	BB 250	A	250	215	190	220	130	15	159	13	109	20	30	150	165	20	250
132	BB 300	A	300	265	240	265	160	18	190	13	135	20	35	180	198	20	300
160 - 180	BB 350	B	350	300	270	310	250	20	290	17	190	30	70	215	240	30	350