

Description

- Two-speed hand pump in oxidized aluminum.

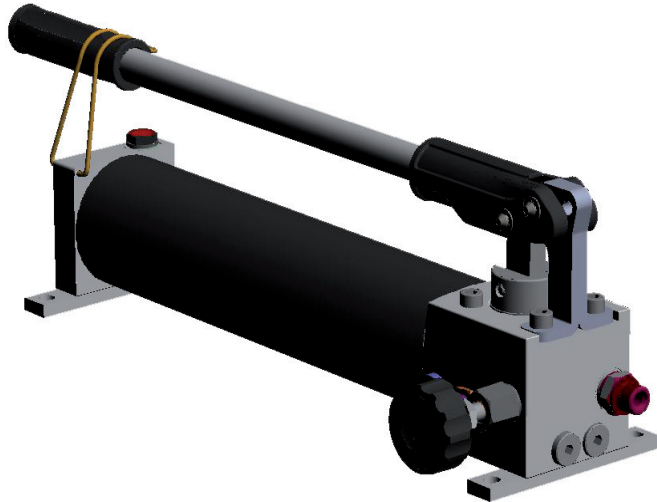

Data Sheet

- 1) Tank 1,2L
- 2) Filler Plug
- 3) Release Handknob
- 4) Pressure Port 3/8"Gas bspp
- 5) Relief Valve
- 6) Gauge port

Lever L 430mm

Dimensions LxWxH 175 x 480 x 164 mm

Oil Mobil Nuto H32

