

Valvola overcentre doppio effetto modulare – luce 6  
 Double effect overcentre valve, sandwich mounting – NG6

mod. OVC-DE-F-C3

Corpo in alluminio  
 Aluminium body

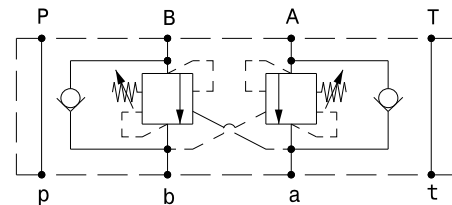
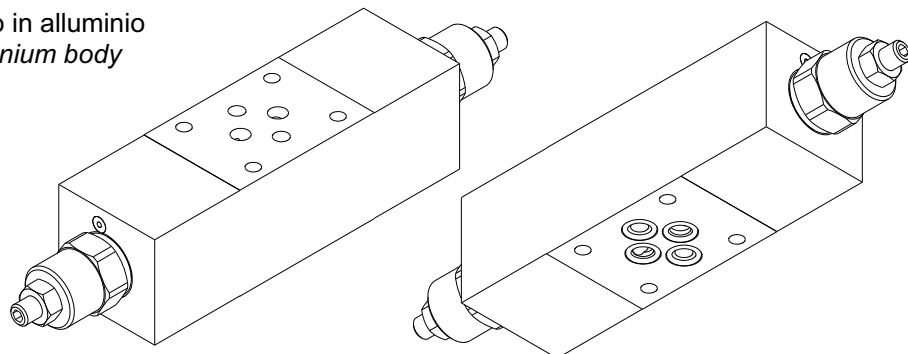

Portata massima Maximum flow	35 l/min
Pressione massima Maximum pressure	350 bar
Rapporto di pilotaggio standard Standard pilot ratio	4,25:1
Rapporto di pilotaggio a richiesta Pilot ratio upon request	3:1 8:1 10:1

<b>Taratura Setting</b>	La valvola deve essere tarata almeno 1.3 volte la massima pressione indotta dal carico The valve must be set at least 1.3 times maximum load induced pressure		
Codice Code	Taratura standard Standard setting bar (Q=5 l/min)	Campo di taratura Adj. Pressure range bar	Colore molla Spring color
01	100	20÷200	Bianco White
02	280	50÷350	Nero Black

Regolazioni Adjustments

- 	C 	D 
Vite esterna esagono incassato Leakproof hex socket screw	Piombatura Sealing cap	Cappellotto Cap

Dati e tarature ottenuti usando olio con viscosità 30 cSt a 50°C Performaces and calibrations are carried out by using hydraulic oil with 30 cSt viscosity at 50°C	
Viscosità consigliate Recommended viscosity	10 + 420 cSt
Temperatura di lavoro Working temperature	-20 + +90 °C
Filtrazione assoluta Absolute filtration	25 µ

Sigla di ordinazione / Ordering code

OVC-DE-F-C3 — 02 — -

Modello  
Type

Codice Taratura  
Setting code  
01, 02

Codice regolazione  
Adjustment code  
-, C, D

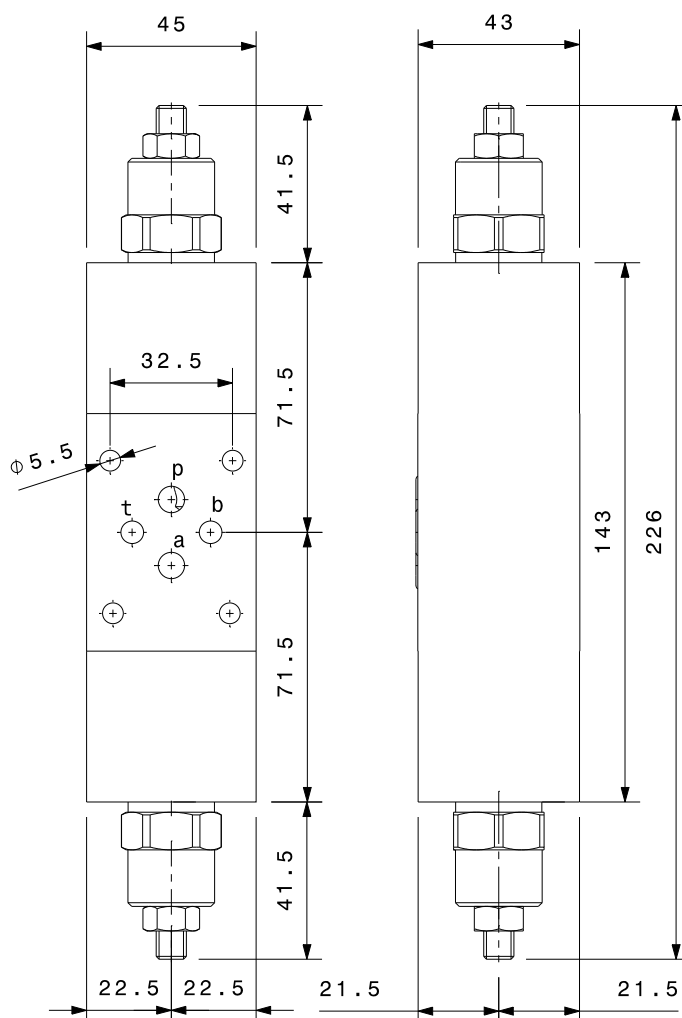

I dati non sono impegnativi, CBF si riserva di apportare modifiche senza preavviso.  
 The specifications are not binding, CBF reserves the right to introduce modifications without notice.