

Folding hydraulic crutch

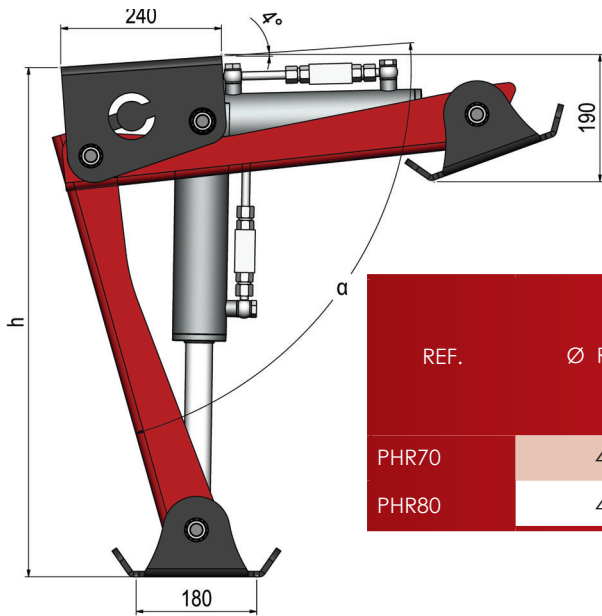

REF.	Ø ROD	BORE	STROKE Z	INLET THREAD	WEIGHT (kg)
PHR70	40	70	200	3/8"G	31,2
PHR80	40	80	200	3/8"G	33,3

CHARACTERISTICS

- Hydraulic crutch with double acting cylinder
- Use: stabilizer for trailer front shaft
- Maximum pressure: 200 bar
- Maximum speed: 0.5 m/s
- Temperature: -30° a 90°
- Mineral hydraulic oil
- Finishing: Black primer

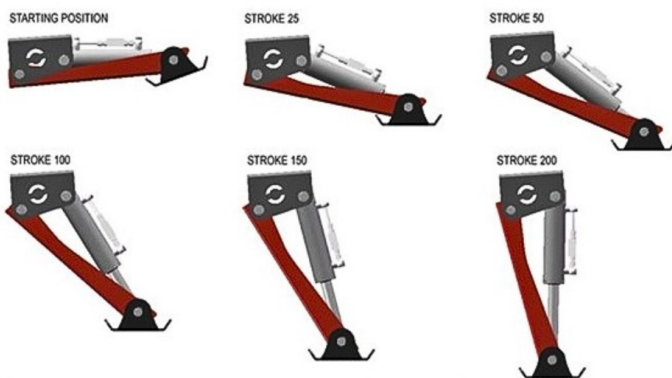

POSITION	α	HEIGHT	LOAD PHR70	LOAD PHR80
STARTING	1°	180	-	-
STROKE 25	16°	352	3500	4500
STROKE 50	27°	459	5000	6600
STROKE 100	45°	586	6800	8800
STROKE 150	62°	695	7500	9800
STROKE 200	78°	759	7600	10000

RECOMMENDATIONS

- Check the oil cleanness (pollution), grease frequently, check that there are no obstacles blocking the free movement of parts
- Do not Weld on the cylinder. To weld on any other component, please take pieces apart first
- In case of long-term storage under severe weather conditions, the rod must be fully retracted and greased