



## FAH SERIES

In line spin-on type filters

Inline filters with spin-on cartridge, suitable for use on return or low pressure line.

Available with or without bypass, indicator port is a standard option to fit a visual or electrical indicator.



### HOUSING

tested according to NFPA T3.10.17, ISO12829, ISO3968

**PRESSURE:** Max operating 14 bar for FAH-A15x - FAHD-A15x  
Max operating 17 bar for FAH-A14x  
Burst: 20 bar for FAH-A15x - FAHD-A15x  
Burst: 28 bar for FAH-A14x

**CONNECTIONS:** G 3/4" ÷ G 1 1/2"  
SAE Flange 1 1/2" 3000 psi

**MATERIALS:** Head: aluminium alloy  
Bowl: painted steel  
Seal: NBR

**BYPASS VALVE:** 3,5 bar

### ELEMENT

tested according to ISO 11170, 2941, 2942, 2943, 3724, 3968, 16889, 16908, 23181

**FILTER MEDIA:** Inorganic microfiber:  
G03 - G06 - G10 - G25 - G40 - GW03 -  
GW06 - GW10 - GW25  
Paper:  
C10 - C25 - CW25  
Wire mesh:  
T60 - T125

**COLLAPSE PRESSURE:** 5 bar

**TEMPERATURE RANGE:** from -30 °C to +100 °C

**FLUID COMPATIBILITY:** Full with HH-HL-HM-HV  
HETG-HEES (acc. to ISO 6743/4).  
For use with other fluid please  
contact Filtrec Customer Service  
(info@filtrec.it).

## OVERALL DIMENSIONS

### FAH - A14x

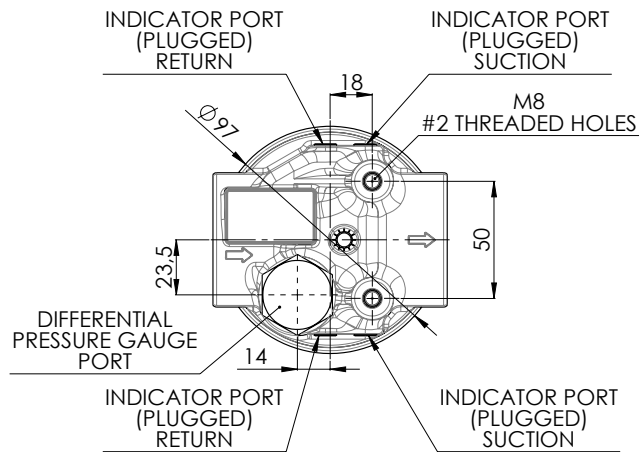
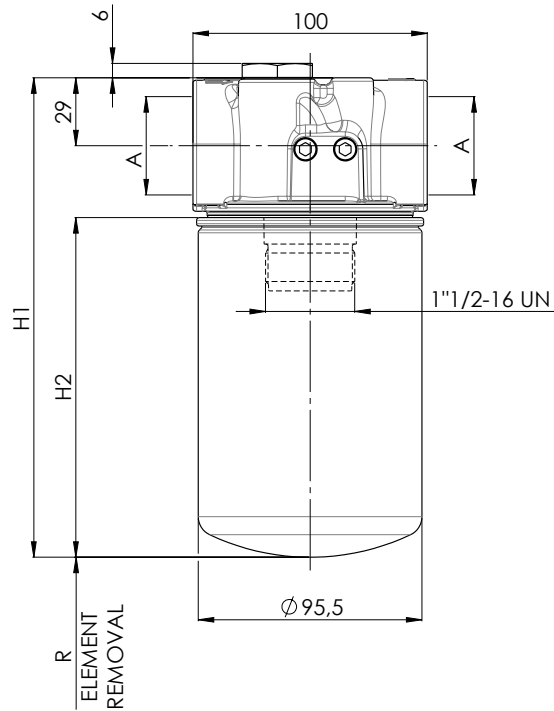

## NOMINAL SIZE

CODE	A	H1	H2	R	WEIGHT
FAH - A140	G 3/4"	205	145	20	1,2 Kg
FAH - A142	G 1"	270	210		1,4 Kg
	G 1 1/4"				

## OVERALL DIMENSIONS

### FAH - A15x

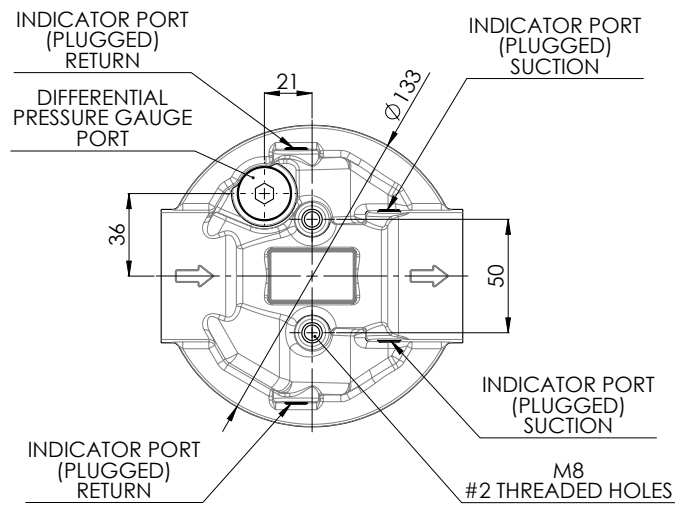
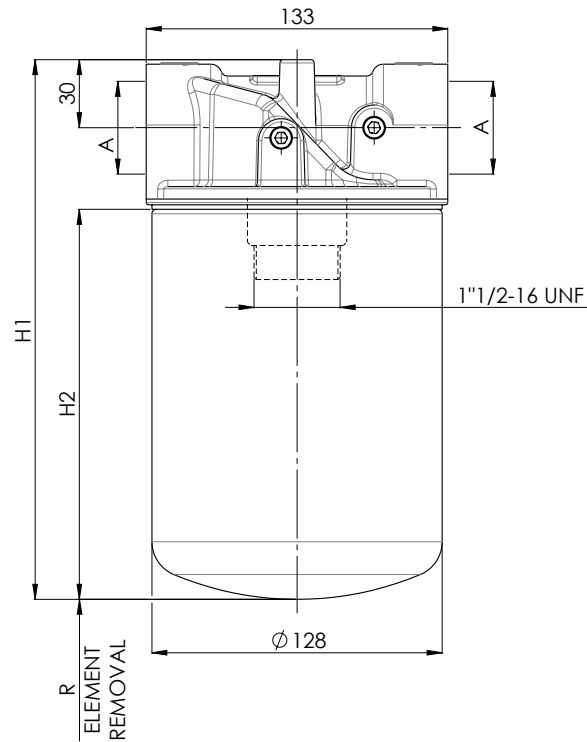

## NOMINAL SIZE

CODE	A	H1	H2	R	WEIGHT
FAH - A150	G 1 1/4"	238	172	40	2 Kg
FAH - A152		398	266		2,3 Kg

## OVERALL DIMENSIONS

### FAHD - A15x

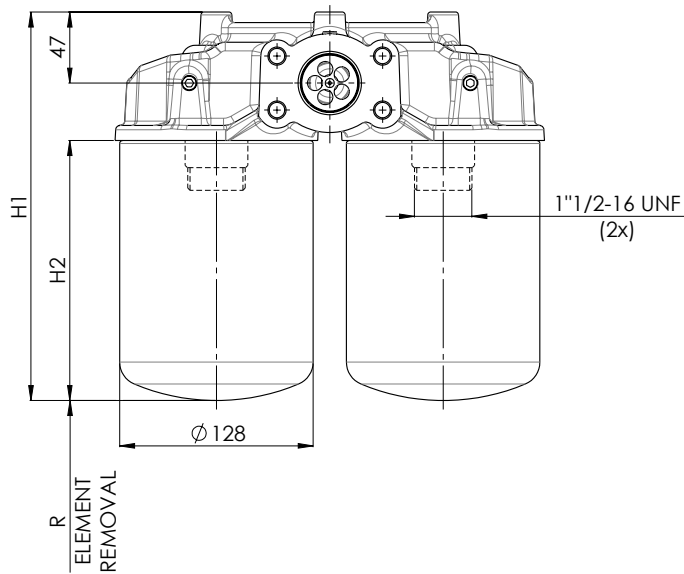

DETAIL FOR CONNECTION B6F7M

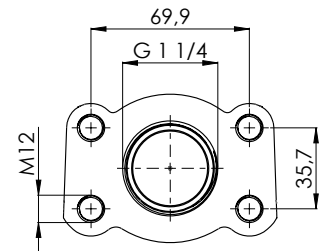

G1 1/4 + 1 1/2" SAE J518-3000 - M12

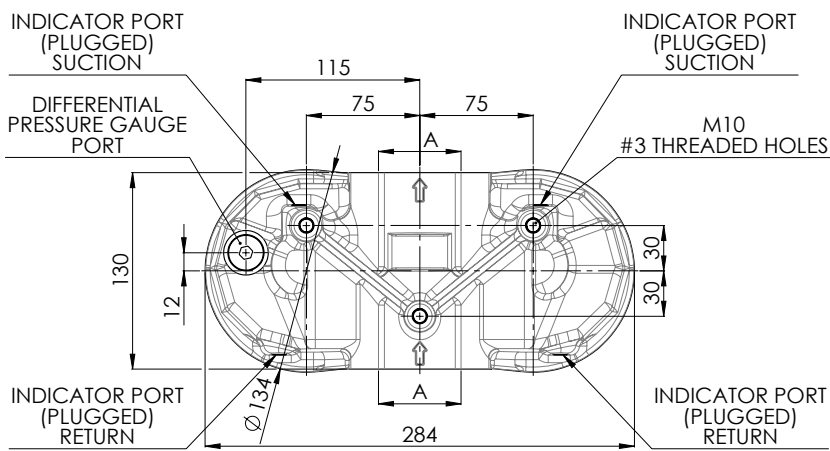

## NOMINAL SIZE

CODE	A	H1	H2	R	WEIGHT
FAHD - A150	G 1 1/2	257	172	40	6,4 Kg
FAHD - A152	G1 1/4" + 1 1/2" SAE J518-3000 - M12	351	266		7 Kg

## ORDERING INFORMATION

	1.	2.	3.	4.	5.	6.	7.	8.	9.	10.	11.
	<b>FAH</b>	<b>A1</b>	<b>50</b>	<b>G25</b>	<b>B</b>	<b>B6</b>	<b>D</b>	<b>S</b>	<b>000</b>	<b>S</b>	<b>0</b>
SPARE ELEMENT		<b>A1</b>	<b>50</b>	<b>G25</b>							

1. FILTER SERIES	FAH	
	FAHD	
2. FILTER ELEMENT SERIES	A1	
3. FILTER SIZE	40-42	only for FAH
	50-52	
4. FILTER MEDIA	000	no element
	G03	glassfiber $\beta_{5\mu\text{m(c)}} > 1.000$
	G06	glassfiber $\beta_{7\mu\text{m(c)}} > 1.000$
	G10	glassfiber $\beta_{12\mu\text{m(c)}} > 1.000$
	G25	glassfiber $\beta_{22\mu\text{m(c)}} > 1.000$
	G40	glassfiber $\beta_{35\mu\text{m(c)}} > 1.000$
	GW03	glassfiber $\beta_{5\mu\text{m(c)}} > 1.000$ + water absorbent
	GW06	glassfiber $\beta_{7\mu\text{m(c)}} > 1.000$ + water absorbent
	GW10	glassfiber $\beta_{12\mu\text{m(c)}} > 1.000$ + water absorbent
	GW25	glassfiber $\beta_{22\mu\text{m(c)}} > 1.000$ + water absorbent
	C10	paper $\beta_{10\mu\text{m(c)}} > 2$
	C25	paper $\beta_{25\mu\text{m(c)}} > 2$
	CW25	paper $\beta_{25\mu\text{m(c)}} > 2$ + water absorbent
	T60	wire mesh 60 $\mu\text{m}$
T125	wire mesh 125 $\mu\text{m}$	
5. SEALS	B	NBR ommitted for spare elements
6. CONNECTIONS	B4	G 3/4" for size 40-42 only
	B5	G 1"
	B6	G 1 1/4"
	B7	G 1 1/2"
	B6F7M	G 1 1/4" or 1 1/2" SAE J518-3000 psi - M12 for FAHD-50-52 only
7. BYPASS VALVE	0	no bypass on request only for size 40-42
	D	3,5 bar
8. INDICATOR PORT	S	differential with metal plug
	W	differential with plastic plug
9. COMPULSORY FIELD	000	filtrec standard
10. CORROSION PROTECTION	S	standard
11. OPTIONS	0	standard

## ACCESSORIES

The accessories must be ordered separately

### INDICATOR

For other options see clogging indicators catalogue

MPC	pressure gauge 0÷10 bar setting 3 bar	
MRC	pressure gauge 0÷10 bar setting 3 bar	
PDC	pressure switch 2 bar SPDT	
VE02	differential visual-electric 2,7 bar	
V02	differential visual 2,7bar	for size 40-42 only
E02	differential electric 2,7bar	
E02L	differential electric 2,7bar + LC24*	
Z34	differential visual 2,7 bar	for size 50-52 only
Z35	differential electric 2,7 bar SPST	
LC24	LED connector for pressure switch	
P01	metal plug for indicator port - NBR	for size 40-42 only
P02	metal plug for indicator port - NBR	for size 50-52 only

### PLUG

## HYDRAULIC SYMBOLS

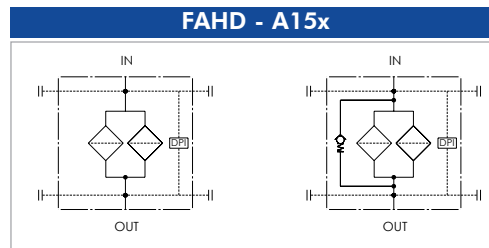
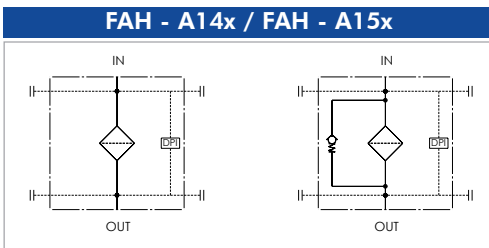

## PRESSURE DROP ( $\Delta p$ ) INFORMATION FOR FILTER SIZING

The total Delta P through a filter assembly is given from Housing  $\Delta p$  + Element  $\Delta p$ . This ideally should not exceed 0,5 bar for return application (it should never exceed 1/3 of the set value of the by-pass valve).

N.B. All the reported data have been obtained at our laboratory, according to specification ISO3968 with mineral oil having 32 cSt viscosity and density 0,875 Kg/dm<sup>3</sup>.

## HOUSING PRESSURE DROP

The housing  $\Delta p$  is given by the curve of the considered model and port, in correspondence of the flow rate value.

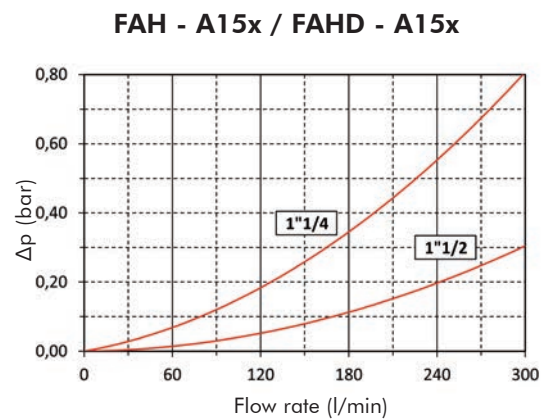
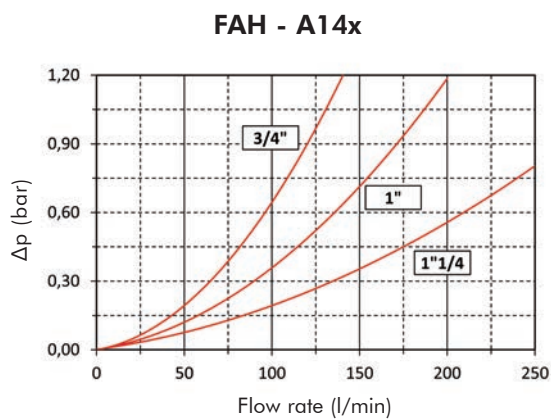

## ELEMENT PRESSURE DROP

The element  $\Delta p$  (bar) is given by the flow rate (l/min) multiplied by the factor in the table here below corresponding to the selected media and divided by 1000. If the oil has a viscosity  $V_x$  different than 32 cSt a corrective factor  $V_x/32$  must be applied.

Example: 120 l/min with A150G25 and oil viscosity 46 cSt:  $(120 \times 1,41)/1000 \times (46/32) = 0,24$  bar

Example: 120 l/min with (\*1) 2x A150G25 and oil viscosity 46 cSt:  $(120 \times 0,71)/1000 \times (46/32) = 0,12$  bar

	G03	G06	G10	G25	G40	GW03	GW06	GW10	GW25	C10	C25	CW25	T60	T125
<b>A140</b>	6,92	6,39	3,83	2,98	1,99	19,52	18,02	10,81	8,41	2,02	1,81	5,11	0,96	0,64
<b>A142</b>	4,47	4,16	3,54	1,66	1,03	12,61	11,73	9,97	4,69	1,66	0,94	2,64	0,52	0,26
<b>A150</b>	4,98	4,22	2,68	1,41	0,72	14,03	11,89	7,55	3,99	0,77	0,65	1,85	0,31	0,26
<b>A152</b>	3,16	2,30	1,72	0,86	0,45	8,91	6,48	4,86	2,43	0,52	0,40	1,14	0,20	0,17
<b>(*1) 2 x A150</b>	2,49	2,11	1,34	0,71	0,36	7,02	5,95	3,77	1,99	0,38	0,33	0,92	0,15	0,13
<b>(*2) 2 x A152</b>	1,58	1,15	0,86	0,43	0,22	4,45	3,24	2,43	1,21	0,26	0,20	0,57	0,10	0,08

(\*1) values for FAHD-A150 (\*2) values for FAHD-A152. These sizes are fitting 2 cartridges each

## EXAMPLE OF TOTAL $\Delta p$ CALCULATION

FAHA150G25BB6DS000S0 with 120 l/min and oil 46 cSt:

Housing  $\Delta p$  0,19 bar + element  $\Delta p$  0,24 bar  $(120 \times 1,41)/1000 \times (46/32) =$  Total assembly  $\Delta p$  0,43 bar.

FAHDA150G25BB7DS000S0 with 120 l/min and oil 46 cSt:

Housing  $\Delta p$  0,05 bar + element  $\Delta p$  0,12 bar  $(120 \times 0,71)/1000 \times (46/32) =$  Total assembly  $\Delta p$  0,17 bar

## BYPASS VALVE PRESSURE DROP

The bypass valve  $\Delta p$  is given by the curve of the considered model and setting, in correspondence of the flow rate value.

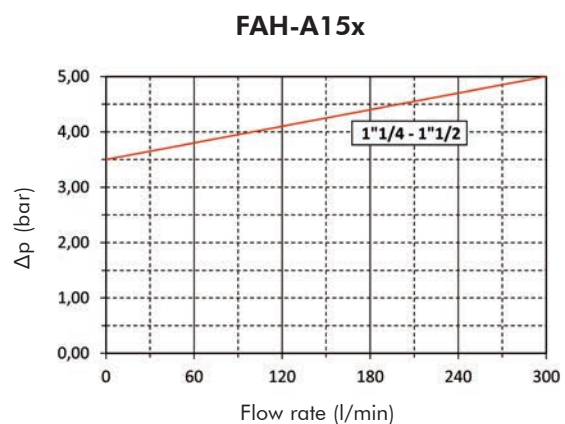
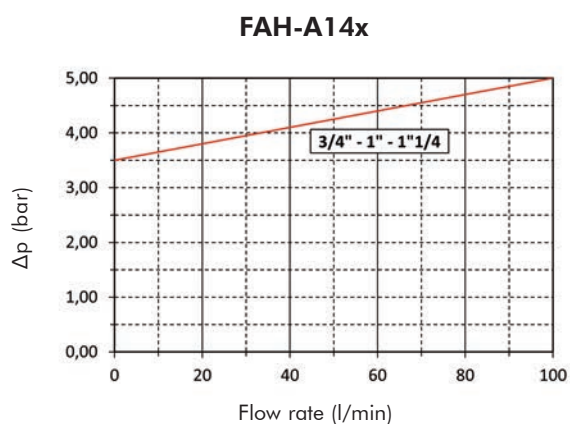



## USER TIPS

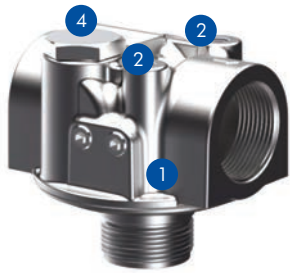

- 1 FILTER HEAD
- 2 FIXING HOLES
- 3 FILTER CARTRIDGE
- 4 IDENTIFICATION LABEL



### CARTRIDGE TIGHTENING TORQUE

All models	3/4 turn
------------	----------

### INDICATOR TIGHTENING TORQUE

Differential pressure gauge	50 Nm
-----------------------------	-------



## WARNING

-  Make sure that Personal Protective Equipment (PPE) is worn during installation and maintenance operation.

## DISPOSAL OF FILTER ELEMENT

-  The used filter elements and the filter parts dirty of oil are classified as "Dangerous waste material": they must be disposed according to the local laws by authorized Companies.



## INSTALLATION

-  1. the IN and OUT ports must be connected to the hoses in the correct flow direction (an arrow shows on the filter head (1))
- 2. the filter housing should be preferably mounted with the cartridge (3) downward
- 3. secure to the frame the filter head (1) using the threaded fixing holes (2)
- 4. verify that no tension is present on the filter after mounting
- 5. enough space must be available for filter element cartridge replacement
- 6. the visual clogging indicator must be in a easily viewable position
- 7. when a electrical indicator is used, make sure that it is properly wired
-  8. never run the system with no filter element fitted
- 9. keep in stock a spare FILTREC filter element for timely replacement when required

## OPERATION

-  1. the filter must work within the operating conditions of pressure, temperature and compatibility given in the first page of this data sheet
- 2. the filter element must be replaced as soon as the clogging indicator signals at working temperature (in cold start conditions, oil temperature lower than 30°C, a false alarm can be given due to oil viscosity)
- 3. If no clogging indicator is mounted, replace the element according to the system manufacturer's recommendations

## MAINTENANCE

-  1. make sure that the system is switched off and there is no residual pressure in the filter
- 2. unscrew the filter cartridge (3) by turning it anti-clockwise and remove it
- 3. fit a new FILTREC cartridge element (3), verifying the part number, particularly concerning the micron rating
- 4. ensure that the head mounting face is clean
-  5. lubricate the gasket of the replacement cartridge and the thread prior to assembly
- 7. spin on the new cartridge until it reaches the mounting face and tighten for 3/4 turn.

