



FDD040 SERIES

Duplex low pressure filters

Sizes 630 to 1000 according to DIN 24550

Inline filters for operating pressure up to 40 bar, flow rate up to 1000 l/min.

Duplex construction for uninterrupted service. Change over valve on upstream side, ergonomic switch-over handle with safety lock and pressure compensation.



HOUSING

tested according to NFPA T3.10.5.1, ISO 10771, ISO 3968

PRESSURE: max operating 40 bar

CONNECTIONS: SAE Flange 2 1/2" 3000 psi

MATERIALS: Filter body: painted carbon steel
Filter head: painted cast iron
Filter bowl: painted cast iron
Seals: NBR

BYPASS VALVE: 3,5 bar

ELEMENT

tested according to ISO 11170, 2941, 2942, 2943, 3724, 3968, 16889, 16908, 23181

FILTER MEDIA: glassfiber G01 - G03 - G06 - G10 - G15 G25

COLLAPSE PRESSURE: 20 bar
210 bar

TEMPERATURE RANGE: -30°C +100°C

FLUID COMPATIBILITY: Full with HH-HL-HM-HV HETG-HEES (acc. to ISO 6743/4).
For use with other fluid please contact Filtrec Customer Service (info@filtrec.it).

OVERALL DIMENSIONS

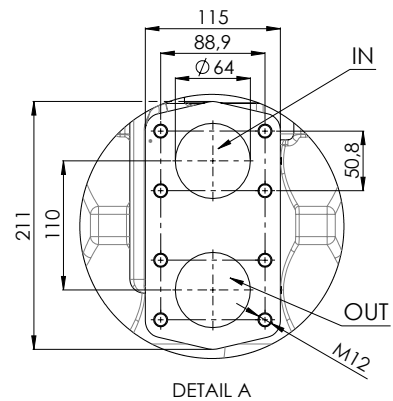
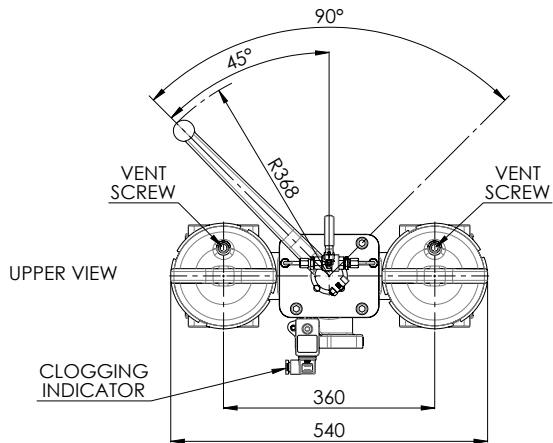
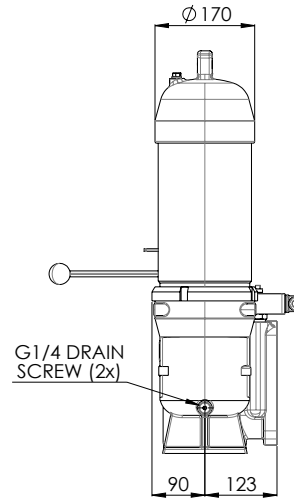
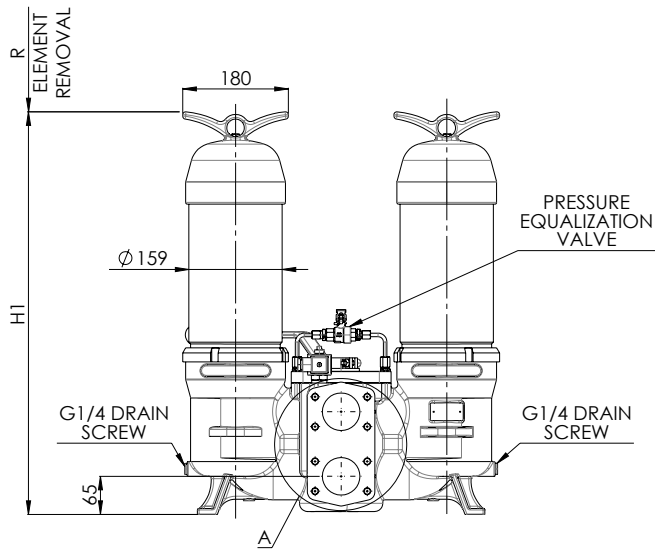

IN & OUT FLANGES
SAE 2-1/2" 3000 psi - M12
DN64

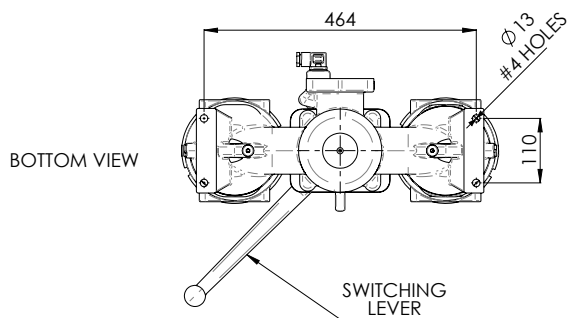

NOMINAL SIZE

MODEL	H1	R	WEIGHT
FDD040XD630	690	300	80 Kg
FDD040XD1000	920	530	100 Kg

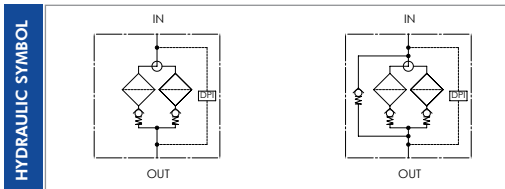

ORDERING INFORMATION

	1.	2.	3.	4.	5.	6.	7.	8.	9.	10.
	FDD040	XD	1000	G10	A	B	F9M	D	W	FG2
SPARE ELEMENT	XD	1000	G10	A						

1. FILTER SERIES	FDD040	
2. FILTER ELEMENT SERIES	XD	
3. FILTER SIZE	630 - 1000	
4. FILTER MEDIA	000	no element
	G01	glassfiber $\beta_{4\mu\text{m(c)}} > 1.000$
	G03	glassfiber $\beta_{5\mu\text{m(c)}} > 1.000$
	G06	glassfiber $\beta_{7\mu\text{m(c)}} > 1.000$
	G10	glassfiber $\beta_{12\mu\text{m(c)}} > 1.000$
	G15	glassfiber $\beta_{17\mu\text{m(c)}} > 1.000$
	G25	glassfiber $\beta_{22\mu\text{m(c)}} > 1.000$
5. ELEMENT COLLAPSE	A	21 bar
	B	210 bar
6. SEALS	B	NBR
7. CONNECTIONS	F9M	2 1/2" SAE 3000 psi - M12
8. BYPASS VALVE	0	no by-pass
	D	3,5 bar
9. INDICATOR PORT OPTION	W	standard
10. INDICATOR	FG2	differential visual and electric 2,2 bar
	FG5	differential visual and electric 5 bar
	FG8	differential visual and electric 8 bar

recommended for no bypass option

PRESSURE DROP (Δp) INFORMATION FOR FILTER SIZING

The total Delta P through a filter assembly is given from Housing Δp + Element Δp .

N.B. All the reported data have been obtained at our laboratory, according to specification ISO3968 with mineral oil having 32 cSt viscosity and density 0,875 Kg/dm³.

HOUSING PRESSURE DROP

The housing Δp is given by the curve of the considered model and port, in correspondence of the flow rate value.

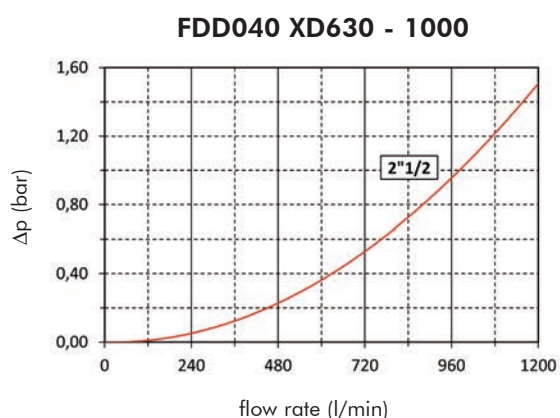

ELEMENT PRESSURE DROP (filter elements 20 bar collapse)

The element Δp (bar) is given by the flow rate (l/min) multiplied by the factor in the table here below corresponding to the selected media and divided by 1000.

If the oil has a viscosity V_x different than 32 cSt a corrective factor $V_x/32$ must be applied.

Example: 400 l/min with XD1000G10A and oil viscosity 46 cSt: $400 \times 0,54/1000 \times 46/32 = 0,31$ bar.

	G01A	G03A	G06A	G10A	G15A	G25A
XD630	2,14	1,5	1,19	0,78	0,6	0,55
XD1000	1,46	1,02	0,82	0,54	0,42	0,39

EXAMPLE OF TOTAL Δp CALCULATION

FDD040XD1000G10ABF9MDWFG2 with 400 l/min and oil 46 cSt:

Housing Δp 0,15 bar + element Δp 0,31 bar ($400 \times 0,54/1000 \times 46/32$) = total assembly Δp 0,46 bar.

ELEMENT PRESSURE DROP (filter elements 210 bar collapse)

The element Δp (bar) is given by the flow rate (l/min) multiplied by the factor in the table here below corresponding to the selected media and divided by 1000.

If the oil has a viscosity V_x different than 32 cSt a corrective factor $V_x/32$ must be applied.

Example: 400 l/min with XD1000G10B and oil viscosity 46 cSt: $400 \times 0,67/1000 \times 46/32 = 0,38$ bar.

	G01B	G03B	G06B	G10B	G15B	G25B
XD630	2,65	1,85	1,47	0,97	0,87	0,7
XD1000	1,81	1,27	1,02	0,67	0,59	0,48

EXAMPLE OF TOTAL Δp CALCULATION

FDD040XD1000G10BBF9MDWFG2 with 400 l/min and oil 46 cSt:

Housing Δp 0,15 bar + element D_p 0,38 bar ($400 \times 0,67/1000 \times 46/32$) = total assembly Δp 0,53 bar.

N.B. All the reported data have been obtained at our laboratory, according to specification ISO3968 with mineral oil having 32 cSt viscosity and density 0,875 Kg/dm³.

USER TIPS



INDICATOR TIGHTENING TORQUE

50 Nm

SPARE SEAL KIT PART NUMBER

	NBR
XD630-1000	06.021.00326

BOWL TIGHTENING TORQUE

screw up filter bowl till end

WARNING

- ⚠ Make sure that Personal Protective Equipment (PPE) is worn during installation and maintenance operation.

DISPOSAL OF FILTER ELEMENT

- ⚠ The used filter elements and the filter parts dirty of oil are classified as "Dangerous waste material": they must be disposed according to the local laws by authorized Companies.

INSTALLATION

- ⚠ 1. The IN and OUT ports must be connected to the hoses in the correct flow direction (an arrow shows on the filter head (1)).
- 2. The filter housing should be preferably mounted with the bowl (8) upward.
- 3. Secure to the frame the filter head (1) using the fixing holes (3).
- 4. Verify that no tension is present on the filter after mounting.
- 5. Enough space must be available for filter element replacement.
- 6. The visual clogging indicator must be in a easily viewable position.
- 7. When a electrical indicator is used, make sure that it is properly wired.
- 8. Never run the system with no filter element fitted.
- ⚠ 9. Keep in stock a spare FILTREC filter element for timely replacement when required.
- 10. Filter housing should be earthed.

OPERATION

- ⚠ 1. The filter must work within the operating conditions of pressure, temperature and compatibility given in the first page of this data sheet.
- 2. The filter element must be replaced as soon as the clogging indicator signals at working temperature (in cold start conditions, oil temperature lower than 30°C, a false alarm can be given due to oil viscosity).
- 3. If no clogging indicator is mounted, replace the element according to the system manufacturer's recommendations.

MAINTENANCE

- ⚠ 1. Operate and hold pressure equalizing lever located behind switching lever. Pull catch knob and swivel switching lever. Place through or drip pan underneath to collect leaving oil. Close pressure equalization valve.
- 2. Loosen vent screw of the filter side not in use by 2-3 turns; max. until contact is made with the safety stop.
- 3. Remove drain plug in housing bottom and drain oil.
- 4. Unscrew filter bowl counter-clockwise.
Warning: The shift and equalizing levers may not, from now until the screwing back in of the filter bowl, be activated under any circumstances!
- 5. Lift out filter element.
- 6. Check seal on filter bowl. We recommend replacement in any case.
- ⚠ 7. Make sure that the order number on the spare element corresponds to the order number of the filter name-plate. To ensure no contamination occurs during the exchange of the element, first open the plastic bag, then push the element over the spigot in the filter head. Now remove plastic bag.
- 8. Push the element carefully over the spigot and tight filter bowl until full stop. Back off the filter bowl 1/8 turn.
- 9. Tighten drain plug housing bottom.
- 10. To refill the filter chamber, operate only the pressure equalizing lever, until fluid emerges bubble-free from the drain cavity.
- 11. Tight vent screw. Check for leakage by actuating the equalizing lever again.

www.filtrec.com

Technical information may change without notice

