



## FBM SERIES

Pressurized air breather filters, with replaceable filter element

This product is suggested in all the applications demanding a precise fluid pressure management during the loading and the emptying of the tank.

Additionally, this product acts as an anti-splash measure minimizing the risk of spills, provided that the hydrostatic pressure remains within safe limits.



### TECHNICAL SPECIFICATION

MATERIALS:	Breather body:	Aluminum with anodic oxidation
	Breather cover:	Zinc plated steel
	Gaskets:	NBR
FILTER MEDIA:	Polyester (air filtration 10 $\mu\text{m}$ )	
	Cellulose (air filtration 3 $\mu\text{m}$ )	
	Glassfiber (air filtration 1 $\mu\text{m}$ )	
PRESSURIZATION VALVE:	0,35 or 0.50 bar	
	0,75 bar on request	
TEMPERATURE RANGE:	-30° C to +100° C	
FLUID COMPATIBILITY:	Full with HH-HL-HM-HV HETG-HEES (acc. to ISO 6743/4). For use with other fluid please contact Filtrec Customer Service (info@filtrec.it).	

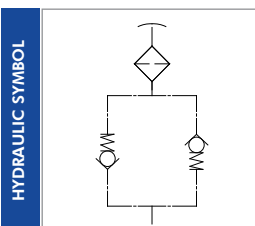

## AIR BREATHER SIZING

---

Air Breathers play a crucial role as part of a hydraulic system's filtration mechanism. The amount of dust retained by an Air Breather depends on various factors, such as the average air dust concentration and the air flow passing through the breather in NI/min. The following table illustrates the typical average air dust concentrations found in real-life environments. Notably, these concentrations can vary significantly, thus impacting the service life of the Air Breather.

DUST CONCENTRATION (depends on application and environment)	$K_{op.cond}$
High level	7 ÷ 10
Medium level	3 ÷ 7
Low level	1 ÷ 3

Measuring the air flow poses a challenging task. Typically, this parameter can be estimated using the following equation:

$$Q_{air\ flow} = K_{op.cond} \times Q$$

Here,  $Q$  represents the flow rate of the hydraulic pump in l/min, and  $K_{op.cond}$  is a multiplicative factor associated with the operating conditions. For instance, in ambient conditions with low dust concentration,  $K_{op.cond}$  may range between 1 and 2, while in environments with high dust concentration, it could be in the range of 7 to 10. It is important to note that  $K_{op.cond}$  is subject to substantial variability, which, in turn, introduces uncertainty in the service life of the Air Breather.



**Filtrec's Air Breathers serve as a fundamental element in every hydraulic system.**

It is essential to bear in mind that removing particles from a hydraulic system incurs significantly higher costs compared to excluding them in the first place.

Given this undeniable truth, it becomes evident that the advantages of utilizing our high-quality air breathers are substantial.

**We highly recommend replacing the air breather with each service interval** (or, at the very least, annually), matching the frequency of replacing the return fluid filters. Doing so ensures optimal performance and longevity of the hydraulic system.

## OVERALL DIMENSIONS

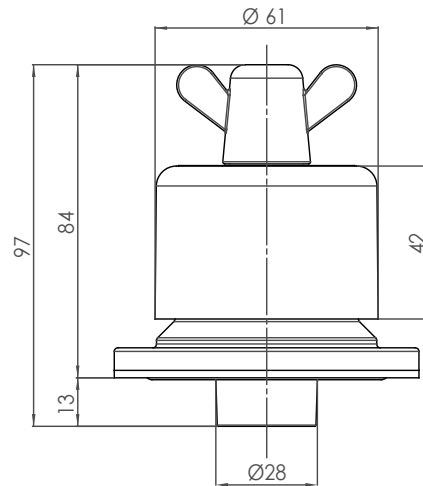

4 FIXING HOLES VERSION

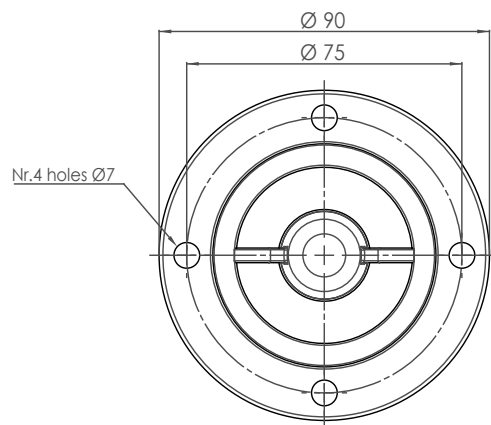

6 FIXING HOLES VERSION

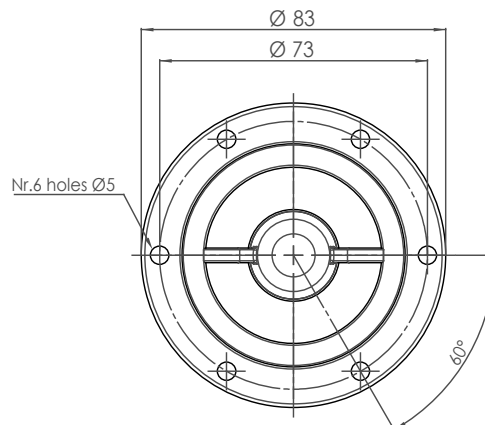

## NOMINAL SIZE

CODE	AIR FLOW RATE l/min Dp 0,015 bar		
	P10	C10	G10
FBMB4	350	300	250
FBMB5	300	250	200

## ORDERING INFORMATION

	1.	2.	3.	4.	5.	6.	7.	8.
	<b>FBM</b>	<b>B4</b>	<b>10</b>	<b>C10</b>	<b>1</b>	<b>4</b>	<b>S</b>	<b>0</b>
SPARE ELEMENT		<b>B4</b>	<b>10</b>	<b>C10</b>				

1. SERIES	FBM		
2. FILTER ELEMENT SERIES	B4		
	B5		
3. FILTER SIZE	10		
4. FILTER MEDIA	P10	polyester (air filtration 10 $\mu\text{m}$ )	For B4 and B5
	C10	cellulose (air filtration 3 $\mu\text{m}$ )	For B4 and B5
	G10	glassfiber (air filtration 1 $\mu\text{m}$ )	Only B5
5. PRESSURIZATION VALVE	1	0,35 bar	
	2	0,50 bar	
	3	0,75 bar (only on request)	
6. FIXING HOLES	4	4 fixing holes	
	6	6 fixing holes	
7. CORROSION PROTECTION	S	standard	
8. OPTIONS	0	no option	

## SPARE ELEMENT B4 AND B5



REFERENCE IMAGE OF B4



REFERENCE IMAGE OF B5

## USER TIPS



### SPARE SEALS KIT (2-5-8)

4 FIXING HOLES	06.021.00421
6 FIXING HOLES	06.021.00422

## WARNING

-  Make sure that Personal Protective Equipment (PPE) is worn during installation and maintenance operation.



## DISPOSAL OF FILTER ELEMENT

-  The used filter elements and the filter parts dirty of oil are classified as "Dangerous waste material": they must be disposed according to the local laws by authorized Companies.

## INSTALLATION

1. Place the gasket (8) on the tank; pay attention to keep the holes aligned.
2. Place the main body (7) on the gasket (8); pay attention to keep the holes aligned.
3. Fix the main body (7) on the tank with the four or six screws and washers (5).
4. Fit the filter element (6) in the main body (7).
5. Put the cover (3) on the main body (7) and the filter element (6) by screwing clockwise by hand.
6. Place the lock seal (2) and screw the lock nut (1) by turning it clockwise by hand.

## MAINTENANCE

1. Unscrew the lock nut (1) by turning it anti-clockwise and remove it along with lock nut seal (2).
-  2. Before removing the element cover (3), ensure that the system is switched off.
-  3. Press the stem (4) to release the air pressure and ensure there is no residual pressure in the oil tank.
4. Unscrew the element cover (3) by turning it anti-clockwise and remove it.
5. Remove the dirty filter element (6).
6. Insert the new FILTREC element (6) by verifying the part number.
7. Screw the element cover (3) by turning it clockwise and tighten it by hand.
8. Check the seals (2+8) conditions and replace if necessary.
9. Screw the lock nut (1) by turning it clockwise, tighten it by hand.

