

# DIESEL ENGINE DRIVEN POWER UNITS

## PRODUCT

- DIESEL ENGINE DRIVEN HYDRAULIC GEAR PUMP SETS
- DIESEL ENGINE DRIVEN HYDRAULIC HI/LO GEAR PUMP SETS
- PRESSURE & TANK CIRCUIT DIESEL ENGINE DRIVEN H FRAME SKID POWER UNIT
- SINGLE ACTING DIESEL ENGINE DRIVEN H FRAME POWER UNITS
- DOUBLE ACTING DIESEL ENGINE DRIVEN H FRAME POWER UNITS
- PRESSURE & TANK CIRCUIT DIESEL ENGINE DRIVEN PORTABLE POWER UNITS
- SINGLE ACTING DIESEL ENGINE DRIVEN PORTABLE POWER UNITS
- DOUBLE ACTING DIESEL ENGINE DRIVEN PORTABLE POWER UNITS

REVAMPED  
SECTION

**LONCIN**



PRICES  
REVIEWED  
AND  
MASSIVELY  
REDUCED

## DIESEL ENGINE DRIVEN HYDRAULIC GEAR PUMP SETS

Diesel pump sets are perfect for installations where no electrical power is available or in conditions suitable solely for diesel. Examples of ideal usage situations are: boatyards, offshore applications, boat applications, mobile applications, agriculture applications, industrial applications, emergency power situations, and any truck mounted for mobility plus cranes and log splitters. Our complete range of diesel driven power packs are based on our range of loncin petrol engines from 2.6kw - 15.3kw, with pressures up to 000 bar and flows up to 63 l/min available on request.

### LONCIN DIESEL ENGINE DRIVEN HYDRAULIC GEAR PUMP SETS

Loncin single cylinder 4-stroke air cooling diesel engine, comes with OMT bell housing, drive coupling and provided with the Flowfit gear pump listed in the table below.

[www.flowfitonline.com](http://www.flowfitonline.com)  
TECH. DATA SHEET  
**DEDPU**



PART NO.	FLOW L/MIN	PRESSURE PSI	PUMP CC	ENGINE HP	ENGINE MODEL
ZZ010400	11.52	3045	3.2	6.5	LC178FD5
ZZ018404	19.5	2537	6.3	10	D460FD5



AVAILABLE  
IN HATZ ON  
REQUEST

## DIESEL ENGINE DRIVEN HYDRAULIC HI-LOW GEAR PUMP SETS

Diesel pump sets are perfect for installations where no electrical power is available or in conditions suitable solely for diesel. Examples of ideal usage situations are: boatyards, offshore applications, boat applications, mobile applications, agriculture applications, industrial applications, emergency power situations, and any truck mounted for mobility plus cranes and log splitters. Our complete range of diesel driven power packs are based on our range of loncin petrol engines from 2.6kw - 15.3kw, with pressures up to 000 bar and flows up to 63 l/min available on request.

### LONCIN DIESEL ENGINE DRIVEN HYDRAULIC HI-LOW GEAR PUMP SETS

Loncin single cylinder 4-stroke air cooling diesel engine, Flowfit bell housing, drive coupling and Flowfit hi-low gear pump

[www.flowfitonline.com](http://www.flowfitonline.com)  
TECH. DATA SHEET  
**DEDPU**



PART NO.	FLOW L/MIN	PRESSURE PSI	PUMP CC	ENGINE HP	ENGINE MODEL
ZZ010401	30.2	3000	8GPM	6.5	LC178FD5
ZZ009231	44.6	3000	11GPM	10	D460FD5

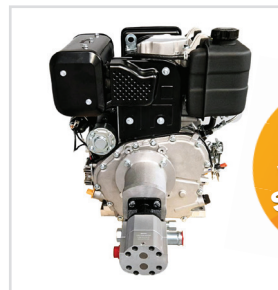

IDEAL  
FOR LOG  
SPLITTERS

## H FRAME DIESEL ENGINE DRIVEN HYDRAULIC SKID SETS

Diesel driven hydraulic power packs are based on a range of Loncin diesel engines from 2.6kw - 15.3kw on request.

Supplied fully assembled and tested, These units offer pressures up to 210 bar and flows up to 63 l/min on request.

All components in stock ready to assemble for immediate delivery. Electric start models have a key start.

**ALL POWER PACKS ARE FULLY ASSEMBLED AND TESTED  
ISSUED WITH 12 MONTHS WARRANTY FROM INVOICE DATE**



### PREMIUM PETROL DRIVEN POWER PACK SERIES CONSISTS OF:

- Loncin diesel engine
- Flowfit gear pump
- Italian OMT bell housing and drive coupling set
- Italian Galtech Q25 1 bank single acting directional control valve. (On single & double acting)
- Filtrec FRTR series tank top return line filter 10 micron c/w visual indicator
- Flowfit 45 litre reservoir c/w removeable lid painted black (ral 9005) 1100mm x 320mm x 480mm
- Filtrec filler breather and Filtrec suction strainer 125 micron
- Filtrec level and temp indicator
- Flowfit branded pressure gauge
- Assembled and mounted on a H frame and tested
- Flowfit branded 2sc hoses
- Engineered by Flowfit

## LONCIN PRESSURE & TANK CIRCUIT DIESEL ENGINE DRIVEN H FRAME SKID POWER UNIT

[www.flowfitonline.com](http://www.flowfitonline.com)  
TECH. DATA SHEET  
**DEDPU**



PT NO	ENGINE TYPE	KW 3600 RPM	HP 3600 RPM	FLOW RATE + MAX PSI	ENGINE START	PUMP TYPE	OIL ALERT YES/NO
ZZ018398	LC178FD5	4.9	6.5	14.4, 3000 PSI	R & ELEC	4CC	YES
ZZ018399	D460FD5	7.5/6.8	10	21.6, 3000 PSI	R & ELEC	6CC	YES

## LONCIN SINGLE ACTING DIESEL ENGINE DRIVEN H FRAME SKID POWER UNIT

[www.flowfitonline.com](http://www.flowfitonline.com)  
TECH. DATA SHEET  
**DEDPU**



PT NO	ENGINE TYPE	KW 3600 RPM	HP 3600 RPM	FLOW RATE + MAX PSI	ENGINE START	PUMP TYPE	OIL ALERT YES/NO
ZZ018400	LC178FD5	4.9	6.5	14.4, 3000 PSI	R & ELEC	4CC	YES
ZZ018401	D460FD5	7.5	10	21.6, 3000 PSI	R & ELEC	6CC	YES

# LONGCIN DOUBLE ACTING DIESEL ENGINE DRIVEN H FRAME SKID POWER UNIT

[www.flowfitonline.com](http://www.flowfitonline.com)  
TECH. DATA SHEET  
**DEDPU**



PT NO	ENGINE TYPE	KW 3600 RPM	HP 3600 RPM	FLOW RATE + MAX PSI	ENGINE START	PUMP TYPE	OIL ALERT YES/NO
ZZ018402	LC178FD5	4.9	6.5	14.4, 3000 PSI	R & ELEC	4CC	YES
ZZ018403	D460FD5	7.5/6.8	10	21.6, 3000 PSI	R & ELEC	6CC	YES

## DIESEL ENGINE PORTABLE HYDRAULIC POWER UNITS

Commercial Self Contained Portable Hydraulic Power Units are designed for heavy duty farm, marine and other commercial applications.

Our HPU's replace farm tractor, truck and other hydraulic power supplies. Use with grain augers, mixers, lifts and other hydraulic applications with pressure available up to 200 bar (2900 psi). We offer a variety of diesel engines from the Loncin range.

Alternatively, Hatz, Changfa or Lombardini commercial diesel engines can be specified, along with electric start/stop on all engine ranges upon request. Please contact our technical support staff to discuss all of your specific requirements.

### SPECIFICATION

AVAILABLE IN HATZ ON REQUEST

- Max Pressure: 200 bar (2900 psi)
- Relief valve mounted on the front of the gear pump (pre-set to 150 bar)
- Gear pump flows available up to 25.5 l/min
- Flowfit branded pressure gauge fitted 0-280 bar (0-4000psi). Unbranded available on request.
- Hydraulic tank/reservoir capacity 50-100 Litres.
- Supplied complete with baffle in tank.
- Built to last
- Collapsible handle assembly for ease of transportation.
- Filtrac suction strainer fitted 125 micron, max flow 30 l/min accessible via bolt down hatch on top of tank

- Anti splash filter.
- Return line filter tank mounted 10 micron cellulose filter element, c/w visual clogging indicator and diffuser and max pressure 8 bar / 116 psi.
- Max flow to return through the return line filter 45 l/min. Can be updated to 65 l/min returnable flow with 125 micron filter element fitted. We recommend regular checking of visual indicator to ensure filter element does not need changing
- Replacement return line filter element is available. We recommend this is changed after the first 20 hours of use to ensure maximum efficiency and cleanliness of the hydraulic powerunit
- Filling Point - Via a visual level indicator c/w with float system. Filler is removeable and allows a constant indication of the hydraulic oil level inside the tank.
- Max Temperature of Oil 80°C

- Flat face quick release couplings 2 off complete fitted on pump outlet and tank top return filter ready to connect your 1/2" bsp male hose connection or male adaptor
- Power Unit fitted with top quality Flowfit hydraulic hose assemblies
- Build with black rubber pressed steel plate swivel castors with brake.
- Full 1 Year Warranty (2 year warranty standard on Loncin engines) Made in England.
- Designed by You - Engineered by Flowfit.



# PRESSURE & TANK CIRCUIT DIESEL ENGINE DRIVEN PORTABLE POWER UNITS

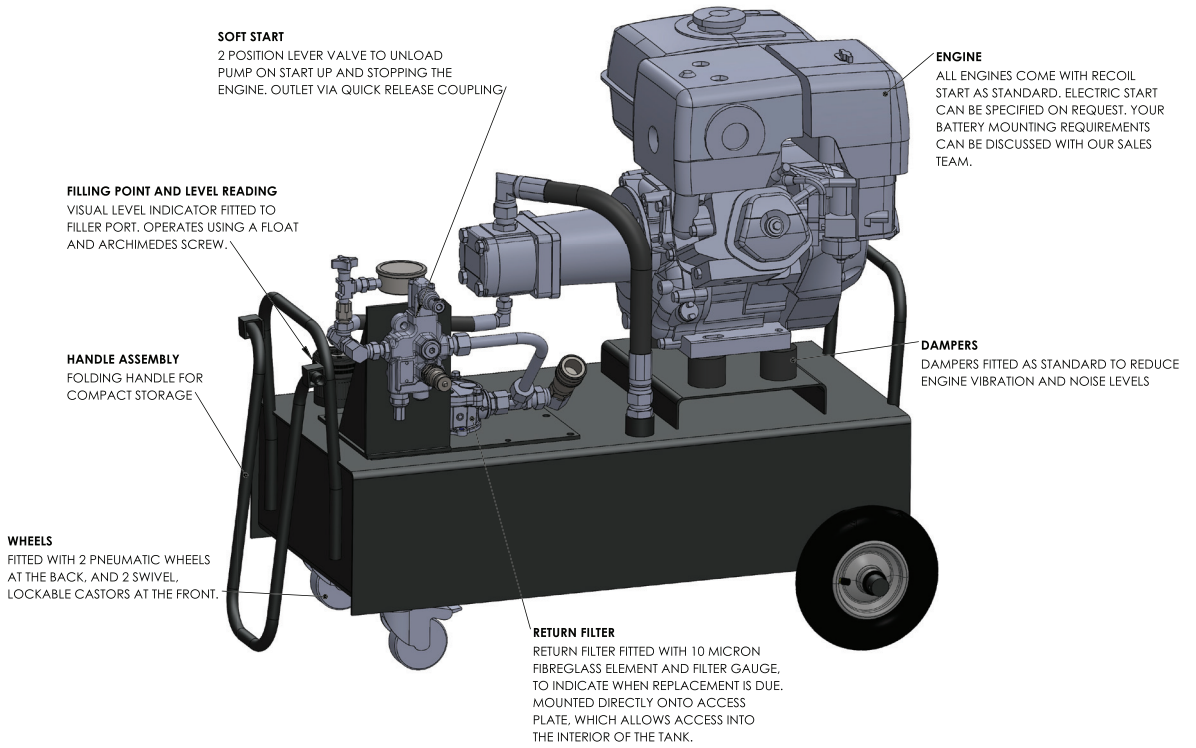

AVAILABLE IN HATZ ON REQUEST

**LONGCIN PRESSURE & TANK CIRCUIT DIESEL ENGINE DRIVEN PORTABLE POWER UNITS**

PRODUCT REFERENCE	ENGINE	HORSE POWER	FLOW RATE	RESERVOIR SIZE
ZZ010353	LC178FD5	6.5HP	11.52 L/min	50 Litres
ZZ010350	D460FD5	10HP	18 L/min	100 Litres



# SINGLE/DOUBLE ACTING DIESEL ENGINE DRIVEN PORTABLE POWER UNITS

**LEVER VALVE**

THE HDM140 SINGLE/DOUBLE ACTING, 3 POSITION SPOOL VALVE IS 3/8" BSP PORTED AND PROVIDES A MAXIMUM FLOW OF 40L/MIN. SPRING RETURN TO NEUTRAL. A RELIEF VALVE IS FITTED TO THE VALVE AND IS PRESET TO 150 BAR. DIFFERENT SPOOL AND POSITIONER CONFIGURATIONS CAN BE SPECIFIED UPON REQUEST.

**HANDLE ASSEMBLY**  
FOLDING HANDLE FOR COMPACT STORAGE

**WHEELS**  
FITTED WITH 2 PNEUMATIC WHEELS AT THE BACK, AND 2 SWIVEL, LOCKABLE CASTORS AT THE FRONT.

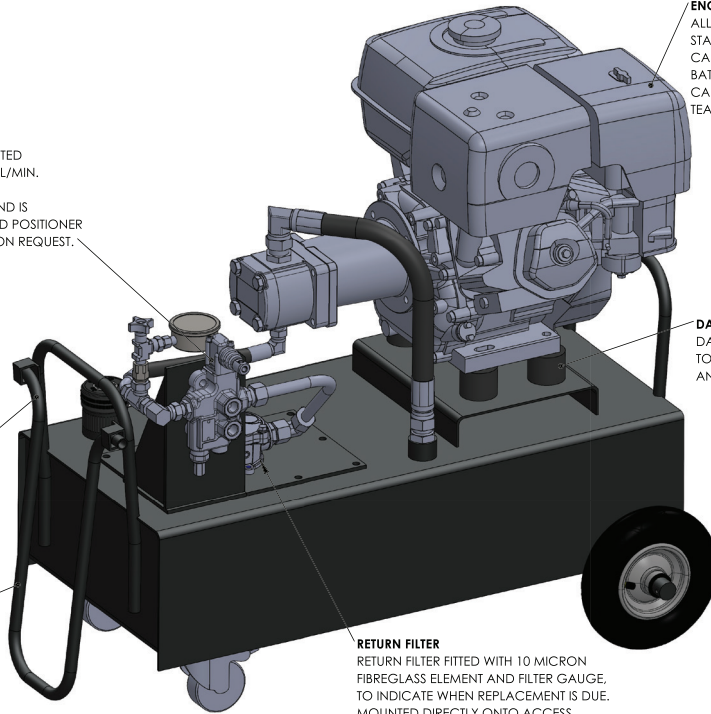

**ENGINE**  
ALL ENGINES COME WITH RECOIL START AS STANDARD. ELECTRIC START CAN BE SPECIFIED ON REQUEST. YOUR BATTERY MOUNTING REQUIREMENTS CAN BE DISCUSSED WITH OUR SALES TEAM.

**DAMPERS**  
DAMPERS FITTED AS STANDARD TO REDUCE ENGINE VIBRATION AND NOISE LEVELS

**RETURN FILTER**  
RETURN FILTER FITTED WITH 10 MICRON FIBREGLASS ELEMENT AND FILTER GAUGE, TO INDICATE WHEN REPLACEMENT IS DUE. MOUNTED DIRECTLY ONTO ACCESS PLATE, WHICH ALLOWS ACCESS INTO THE INTERIOR OF THE TANK.



AVAILABLE IN HATZ ON REQUEST

**LONCIN SINGLE ACTING DIESEL ENGINE DRIVEN PORTABLE POWER UNITS**

PRODUCT REFERENCE	ENGINE	HORSE POWER	FLOW RATE	RESERVOIR SIZE
-------------------	--------	-------------	-----------	----------------

ZZ018396	LC178FD5	6.5HP	11.52 L/min	50 Litres
ZZ018397	D460FD5	10HP	18 L/min	100 Litres

**LONCIN DOUBLE ACTING DIESEL ENGINE DRIVEN PORTABLE POWER UNITS**

PRODUCT REFERENCE	ENGINE	HORSE POWER	FLOW RATE	RESERVOIR SIZE
-------------------	--------	-------------	-----------	----------------

ZZ010352	LC178FD5	6.5HP	11.52 L/min	50 Litres
ZZ010349	D460FD5	10HP	18 L/min	100 Litres