

DRAWING NO:

155100A6312BAAAA

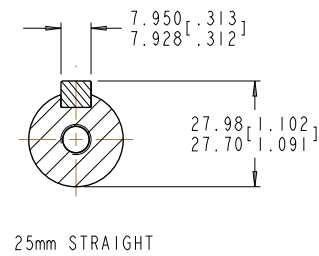
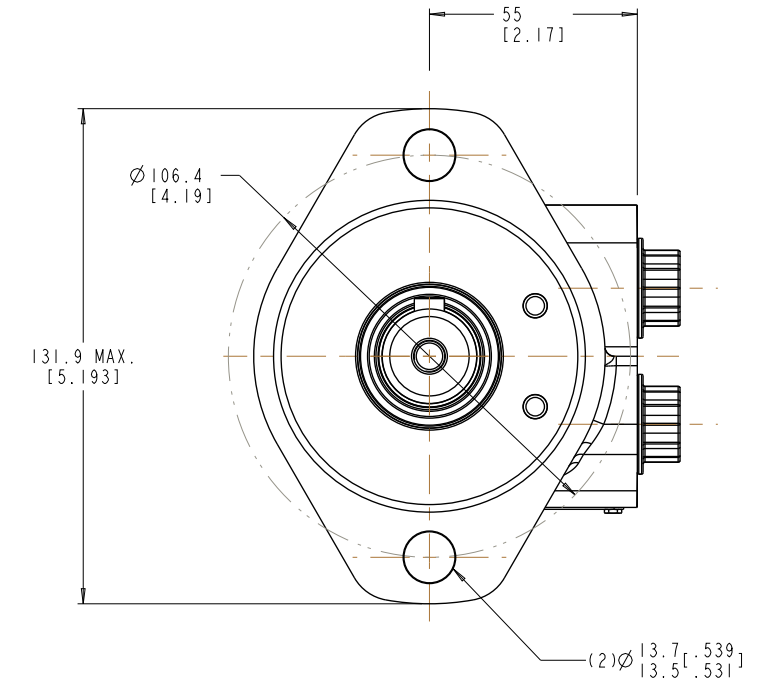
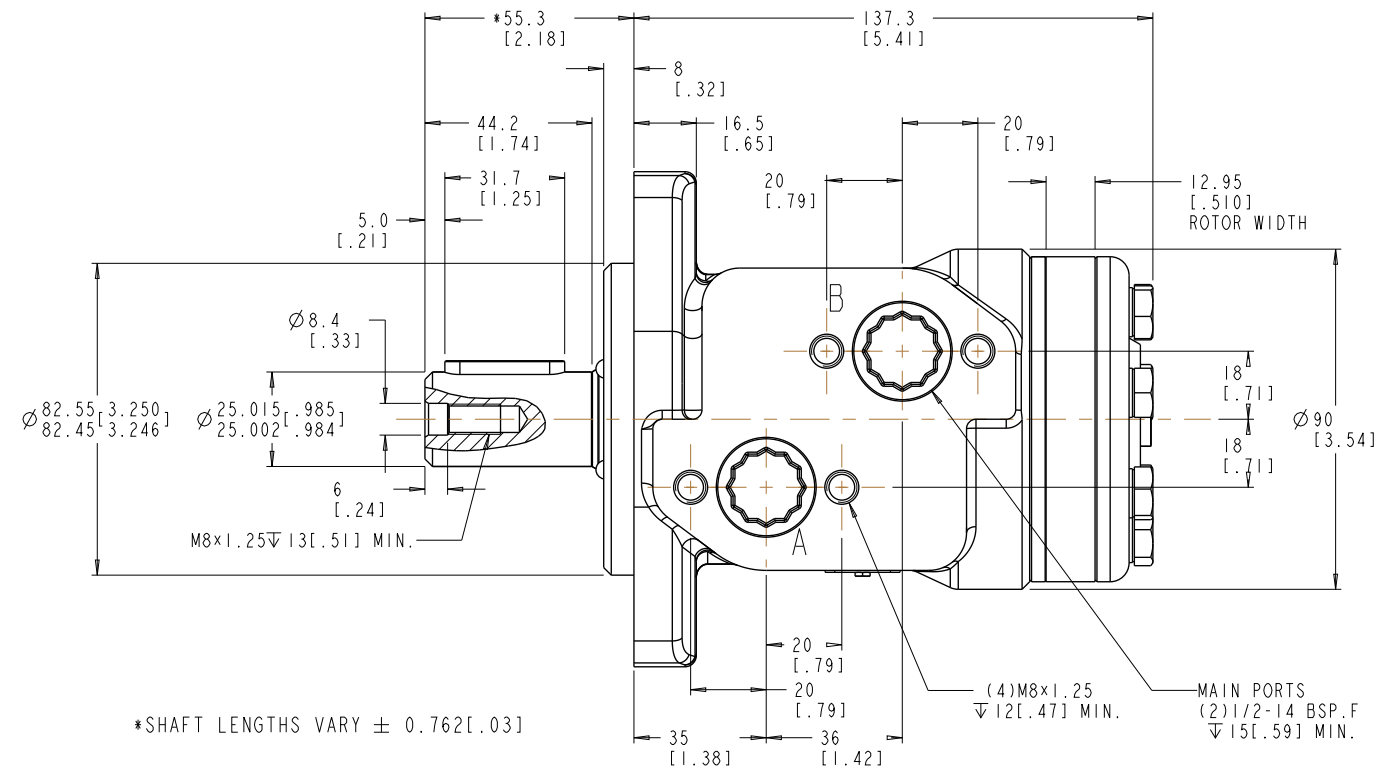
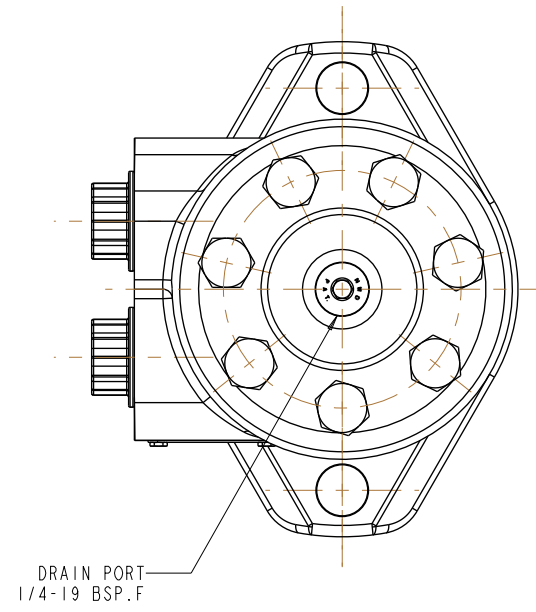

MODEL SPECIFICATIONS

Displacement - cm <sup>3</sup> [in <sup>3</sup> ]	96 [5.9]
Max. Speed - rpm	
Continuous	728
Intermittent	780
Max. Flow - lpm [gpm]	
Continuous	60 [16]
Intermittent	75 [20]
Max. Torque - Nm [lb-in]	
Continuous	195 [1726]
Intermittent	213 [1885]
Max. Pressure - bar [psi]	
Continuous	160 [2320]
Intermittent	175 [2540]
Peak	240 [3480]
Check Valve	Yes
Intermittent operation	10% of every minute
Peak operation	1% of every minute

