

Weldable bulkhead coupling
 Einschweiß-Schottverschraubung
 Union double de cloison à souder

P-ESV

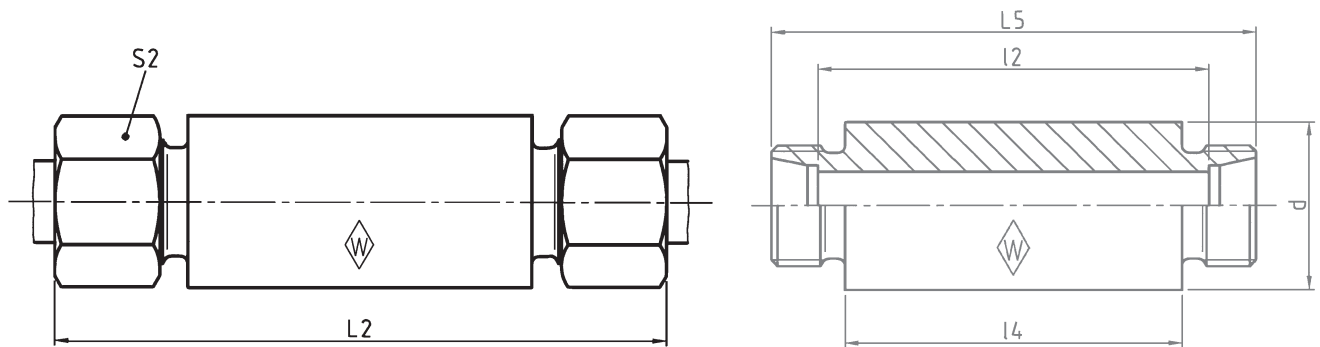

Series	bar	Tube OD	Type	Reference	kg per 100 pcs.	L ₂	L ₅	l ₂	l ₄	d	S ₂
Reihe	PN	Rohr-AD	Typ	Best.-Nr.	kg per 100 St.						
Série	(psi)	Tube Ø ext.	Désignation	Réf.	kg par 100 p.						
L	500 (7252)	6	P-ESV 6 L	WAL373511	13,1	85	70	56	50	18	14
		8	P-ESV 8 L	WAL373512	16,2	85	70	56	50	20	17
		10	P-ESV 10 L	WAL373513	19,5	87	72	58	50	22	19
	400 (5801)	12	P-ESV 12 L	WAL373514	24,1	87	72	58	50	25	22
		15	P-ESV 15 L	WAL373515	35,3	100	84	70	60	28	27
		18	P-ESV S 18 L	WAL373516	46,9	101	84	69	60	32	32
	250 (3626)	22	P-ESV 22 L	WAL373517	58,2	105	88	73	60	36	36
		28	P-ESV 28 L	WAL373518	66,0	106	88	73	60	40	41
		35	P-ESV 35 L	WAL373519	102,9	114	92	71	60	50	50
		42	P-ESV 42 L	WAL373520	148,8	115	92	70	60	60	60
S	800 (11603)	6	P-ESV 6 S	WAL373521	16,9	89	74	60	50	20	17
		8	P-ESV 8 S	WAL373522	20,4	89	74	60	50	22	19
		10	P-ESV 10 S	WAL373523	27,0	91	74	59	50	25	22
	630 (9137)	12	P-ESV 12 S	WAL373524	33,1	91	74	59	50	28	24
		14	P-ESV 14 S	WAL373525	44,7	107	88	72	60	30	27
		16	P-ESV 16 S	WAL373526	57,8	107	88	71	60	35	30
	420 (6091)	20	P-ESV 20 S	WAL373527	73,2	114	92	71	60	38	36
		25	P-ESV 25 S	WAL373528	114,6	120	96	72	60	45	46
		30	P-ESV 30 S	WAL373529	134,4	126	100	73	60	50	50
		38	P-ESV 38 S	WAL373530	191,3	133	104	72	60	60	60

L₂ = approximate length with nut tightened
 L₂ = Ungefährmaß bei angezogener Überwurfmutter
 L₂ = longueur approximative, l'écrou étant bloqué

Body manufactured in weldable quality steel
 Werkstoff der Verschraubungsstützen ist schmelzsweißbarer Stahl
 Le corps est en acier soudable