

## 97500 SERIES CAST IRON SPEED REDUCTION GEARBOXES

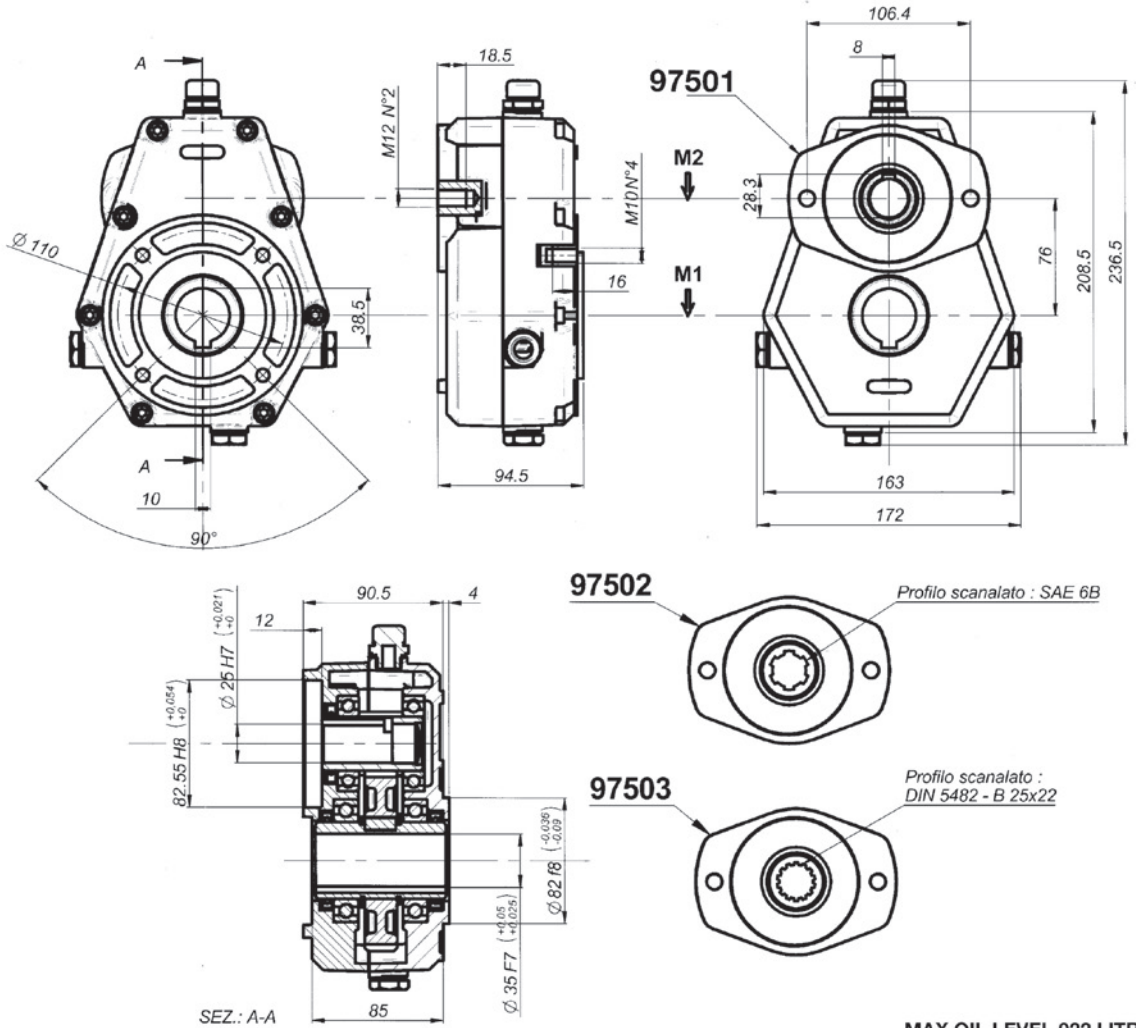

GROUP 2 • SAE 'A' • 18KW



MAX OIL LEVEL 022 LITRE

M1 MAXIMUM CONTINUOUS TORQUE OF THE SPEED INCREASER (Input side daNm)	M2 MAXIMUM TORQUE OF THE SPEED INCREASER (Output side daNm)	N1 OUTPUT SPEED AFTER REDUCTION RPM	N2 INPUT SPEED BEFORE REDUCTION RPM	I RATIO OF SPEED REDUCTION ON N2 = N1	MAX TRANSMITTABLE POWER KW	WEIGHT KG
24,7	16,5	200	300	1,5	18	10
32,4	16,2	200	400	2	18	10
38,7	15,5	200	500	2,5	18	10
24,0	8,0	200	600	3	18	10
25,5	7,5	200	680	3,5	18	10
26,6	7,0	200	760	3,8	18	10