

Hydraulic Imperial Compression Fittings

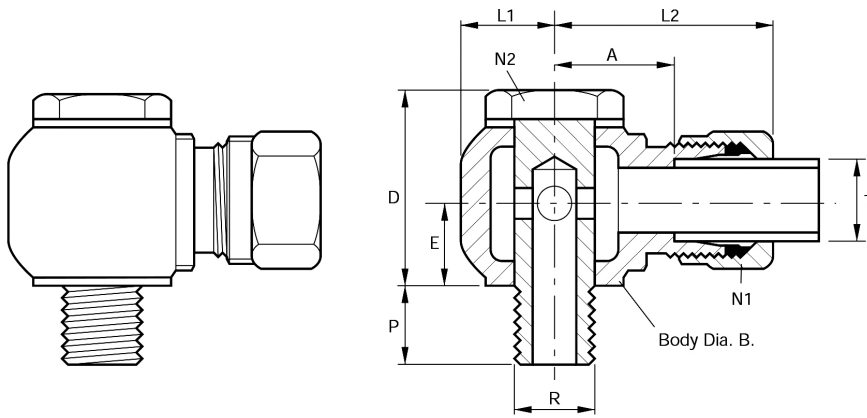

O.D. TUBES

Part No.	Tube Dia. T.	BSP Thread R.	Nut Hex. N1.	Bolt Hex. N2.	Tube Abut. A.	Thread Length P.	C/L to Face E.	Length D.	Body Dia. B.	Overall Length L1.	L2.
2018-9163	1/4"	1/4"	.710"	.710"	3/4"	3/8"	15/32"	1 3/16"	1 1/8"	1/2"	1 15/32"
2018-9205	3/8"	1/4"	.820"	.710"	3/4"	3/8"	17/32"	1 5/16"	1 1/4"	9/16"	1 15/32"
2018-9221	3/8"	3/8"	.820"	.920"	7/8"	7/16"	17/32"	1 5/16"	1 3/8"	5/8"	1 19/32"
2018-9247	1/2"	3/8"	.920"	.920"	1 5/16"	7/16"	19/32"	1 7/16"	1 1/2"	1 1/16"	1 11/16"
2018-9254	1/2"	1/2"	.920"	1.10"	1 1/16"	9/16"	21/32"	1 7/16"	1 5/8"	3/4"	1 13/16"

N.B. TUBES

Part No.	N.B. Tube Size T.	BSP Thread R.	Nut Hex N1.	Bolt Hex N2.	Tube Abut. A.	Thread Length P.	C/L to face E.	Length D.	Body Dia B.	Overall Length L1.	L2.
2018-9296	1/8"	1/8"	.820"	.625"	1 3/16"	5/16"	19/32"	1 7/16"	1 1/4"	9/16"	1 9/16"
2018-9353	1/2"	1/2"	1.375"	1.10"	1 1/4"	9/16"	29/32"	2 3/16"	2"	7/8"	2 1/8"

Part numbers indicated are for **Carbon Steel Couplings** only.
 For **316 Stainless Steel Couplings**, add suffix **SS** to part number.