

15 Displacements	(2.2 – 24.0 in ³ /rev)	
15 Schluckvolumen	36 . . . 390 cm ³ /rev	
15 Cylindrée		
15 Desplazamientos		
	Cont	Int
Maximum Pressure	(1800 psid)	(2400 psid)
Eingangsdruck	. . .125 bar	. . .165 bar
Chaute de pression max.		
Presion Maxima		
Maximum Oil Flow	(15 gpm)	
Schluckstrom	. . . 57 lpm	
Débit d'huile		
Caudal Maximo de Aceite		
Maximum Speed	(932 rpm)	
Drehzahl	932 rpm	
Vitesse de rotation		
Velocidad Maxima		
	Cont	Int
Maximum Torque	(3897 lb in)	(4783 lb in)
Max Drehmoment	440 Nm	540 Nm
Couple Maxi		
Torque Maximo		
Maximum Side Load at Key	(1100 lb)	
Seitenlast	. . . 4900 N	
Charges latérales		
Carga Maxima Lateral		

A Light to Medium Duty Low Speed, High Torque Motor

This light to medium duty motor incorporates all the features of heavy duty motors. Design features include a high pressure shaft seal so external drains are never required, roller vane technology for automatic wear compensation, and full flow internal cooling and flushing. This is a very economical motor for most light to medium duty applications.

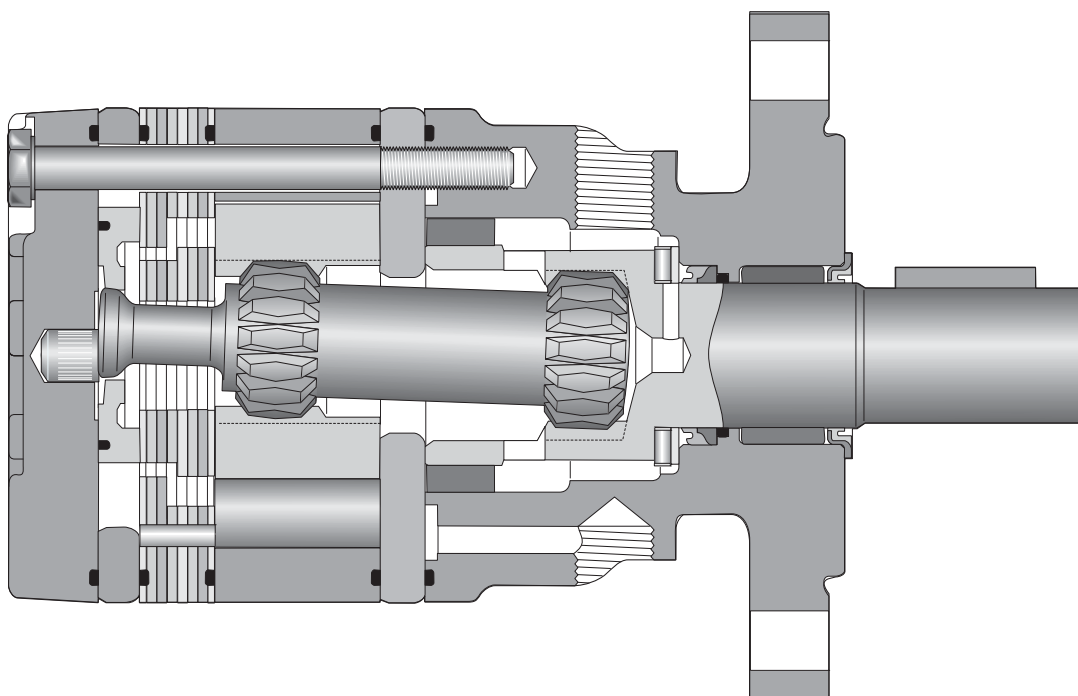

TB

Series



XXXX

Displacement
Schluckvolumen
Cylindrée
Desplazamiento

Code	cm ³ /U cm ³ /tr cm ³ /giro	in ³ /rev
0036	36 / 2.2	
0045	41 / 2.5	
0050	49 / 3.0	
0065	65 / 4.0	
0080	82 / 5.0	
0100	98 / 6.0	
0130	130 / 8.0	
0165	163 / 10.0	
0195	195 / 11.9	
0230	228 / 13.9	
0260	260 / 15.9	
0295	293 / 17.9	
0330	328 / 20.0	
0365	370 / 22.6	
0390	392 / 24.0	



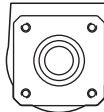

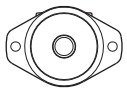
X

Mounting
Gehäuse
Carter
Montaje

Code	Mounting
A	SAE "A" 2 Bolt 
F	4 Bolt w/3/8-16 UNC 
M	Magneto 
C	SAE "A" 2 Bolt, Long Pilot 
B	SAE "B" 2 Bolt 

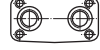
X

Ports
Anschluß
Plan de raccordement
Lumbreras

Code	Ports
M	5/16-18 UNC Manifold 
P	1/2-14 NPTF 
S	7/8-14 SAE 
W	G 1/2 BSPP 



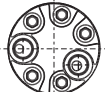





Rear Ports
Endanschluß
Alimentazione Laterale
Orifices arrière

Code	Rear Ports
R	3/4-16 SAE O-ring Axial 
Y	G 1/2 BSPP Axial 

For other available options, see pages 102–103.

XX



Shaft
Welle
Arbre
Eje



Code	Shaft
09	1" Straight w/0.38" Crosshole 
10	1" Keyed 
11	1" 6B Spline 
13	Long 1" Keyed 
21	1" Keyed; Corrosion Resistant 
25	1" Tapered 
26	25mm Keyed w/ 8mm Key 
28	7/8" 13 Tooth Spline 
59*	7/8" 13 Tooth Spline SAE 

* Conforms to SAE B recommended length

0

Rotation
Drehrichtung
Direction de rotation
Rotacion

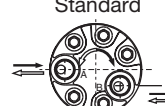
Code	Rotation
0	Standard 
1	Reverse Timed Manifold 

Code	Rear Port Rotation
0	Standard 
1	Reverse Timed Manifold 

Rotation viewed from shaft end.

XXXX

Options
Opciones

Code	Options
AAAA	Black Paint
AAAB	No Paint
AAAC	Double Paint
AAAF	Castle Nut, Black Paint
AABP	Castle Nut, No Paint
AAAG	Fluorocarbon Seals, Black Paint
AAAH	Fluorocarbon Seals, No Paint
AAAJ	High Temperature Commutator Seal, Black Paint
AAFG	High Temperature Commutator Seal, No Paint
AABJ*	Free Running Rotorset, Black Paint
AABK*	Free Running Rotorset, No Paint

*Not applicable to TB0365 or TB0390 displacements

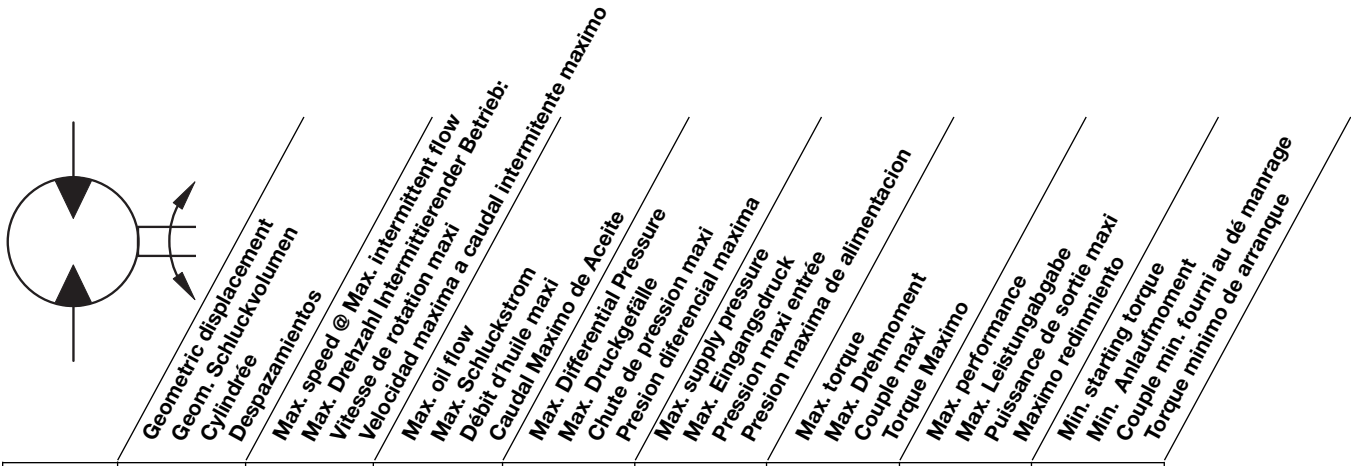

Motor Series TB	cm ³ /rev in ³ /rev	rev/min	cont / int* l/min g/min		cont / int* bar psid		max bar psig	cont / int* Nm lb-in		max KW HP	cont / int* Nm lb-in	
TB 0036	36 2.2	932	34 9	34 9	125 1800	165 2400	190 2750	48 427	67 596	6.6 8.8	44 385	50 440
TB 0045	41 2.5	805	34 9	34 9	125 1800	165 2400	190 2750	64 526	88 731	7.2 9.7	39 341	52 461
TB 0050	49 3.0	678	34 9	34 9	125 1800	165 2400	190 2750	78 693	107 946	7.5 10.1	36 319	70 619
TB 0065	65 4.0	511	34 9	34 9	125 1800	165 2400	190 2750	107 946	145 1284	7.8 10.4	66 582	99 977
TB 0080	82 5.0	409	34 9	34 9	125 1800	165 2400	190 2750	135 1193	184 1624	7.8 10.5	92 816	139 1226
TB 0100	98 6.0	454	45 12	45 12	125 1800	165 2400	190 2750	159 1411	217 1917	10.2 13.8	119 1050	158 1400
TB 0130	130 8.0	430	45 12	57 15	125 1800	165 2400	190 2750	220 1951	297 2632	13.4 18.0	167 1482	229 2024
TB 0165	163 10.0	343	45 12	57 15	125 1800	155 2250	190 2750	273 2418	346 3062	12.4 16.7	199 1760	263 2331
TB 0195	195 11.9	287	45 12	57 15	125 1800	145 2100	190 2750	340 3011	400 3537	12.0 16.1	270 2388	325 2872
TB 0230	228 13.9	246	45 12	57 15	103 1500	138 2000	190 2750	316 2797	427 3782	11.0 14.8	261 2354	353 3121
TB 0260	260 15.9	216	45 12	57 15	100 1450	131 1900	190 2750	350 3096	465 4117	10.5 14.1	291 2573	395 3498
TB 0295	293 17.9	191	45 12	57 15	97 1400	125 1800	190 2750	383 3391	499 4415	10.0 13.4	308 2724	400 3544
TB 0330	328 20.0	171	45 12	57 15	93 1350	114 1650	190 2750	413 3657	509 4505	9.1 12.2	332 2942	406 3590
TB 0365	370 22.6	151	45 12	57 15	86 1250	105 1525	190 2750	440 3897	540 4783	8.7 11.6	372 3296	454 4021
TB 0390	392 24.0	143	45 12	57 15	83 1200	100 1450	190 2750	428 3792	525 4642	7.8 10.5	339 3003	434 3845

Performance data based on testing using 10W40 oil with a viscosity of 43.1 cSt. (200 SUS) at 54° C (130° F). Performance data is typical. Actual data may vary slightly from one production motor to another.

Les donnees sur les performances sont basees sur des tests utilisant de l'huile 10W40 d'une viscosite de 200 SUS a 54°C (130°F). Ces donnees correspondent a des situations typiques. Les donnees reelles peuvent varier legerement d'un moteur de production a l'autre.

Leistungsdaten sind gemessen mit SAE 10W40 bei einer Viskosität von 43,1 Cst bei 54°C. Geringfügige Abweichungen von den Katalogdaten sind möglich.

Datos tecnicos obtenidos con aceite 10W40 de 200 SUS de viscosidad a 54°C (130°F). Los datos proporcionados son valores tipicos. Los valores exactos reales podrian tener una pequena variacion entre distintos motores.

* Intermittent operation rating applies to 10% of every minute.

Intermittierende Werte maximal 10% von jeder Betriebsminute.

Fonctionnement interm. 10% max. de chaque minute d'utilisation.

Capacidad de funcionamiento intermitente valida para 10% por cada minuto.

TB 0036

2.2 cu in / rev PRESSURE (PSID)

	500	1000	1500	1800	2000	2400
.5	108 45	223 37	343 26	418 19	468 15	570 8
1	114 97	234 88	357 77	431 70	481 66	581 57
2	112 202	235 191	361 179	440 172	492 168	598 158
3	113 307	241 295	370 282	450 274	503 269	610 258
4	109 411	241 398	373 384	455 376	509 370	620 358
5	104 515	237 501	371 486	453 477	509 471	621 459
7	87 724	225 708	360 691	443 681	498 674	613 660
9	71 932	208 915	344 896	427 884	483 876	598 860

Flow (GPM)

TORQUE (LB IN) 427
 SPEED (RPM) 884

36 cc / rev

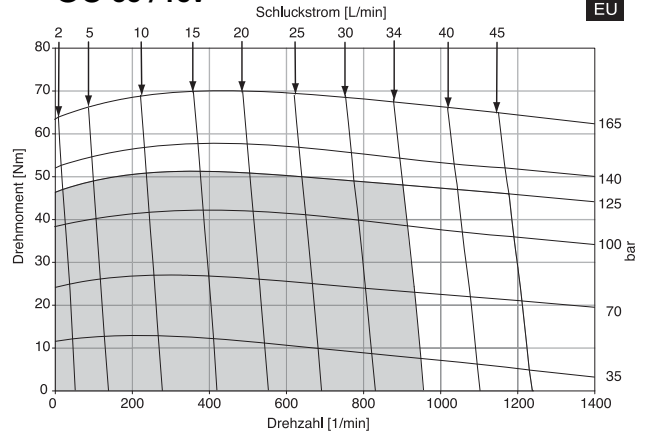

TB 0045

2.5 cu in / rev PRESSURE (PSID)

	500	1000	1500	1800	2000	2400
.5	116 31	263 17				
1	124 76	276 61	427 43	518 36	579 29	706 18
2	134 167	294 149	453 131	547 121	609 113	723 97
3	132 256	293 239	455 220	553 210	617 200	746 183
4	132 344	296 326	465 307	567 295	635 285	769 268
5	128 433	294 414	465 393	569 380	639 370	779 352
7	117 609	284 589	458 566	564 551	635 540	779 520
9	107 785	275 764	449 739	555 722	627 710	770 689

Flow (GPM)

TORQUE (LB IN) 555
 SPEED (RPM) 722

41 cc / rev

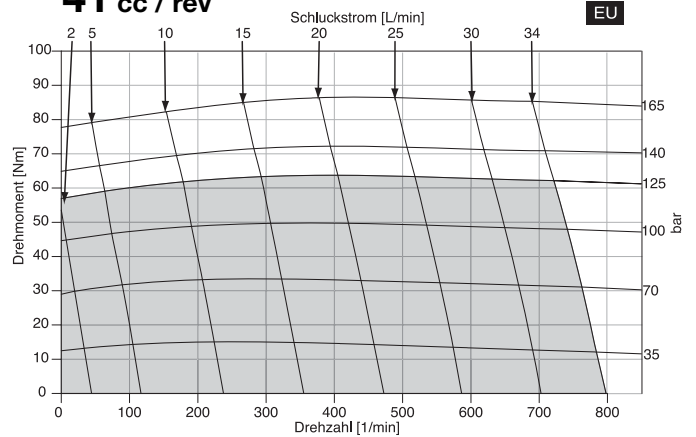

Intermittent operation rating applies to 10% of every minute.
 Fonctionnement intermitt. 10% max. de chaque minute d'utilisation.
 Performance data based on testing using 10W40 oil with a viscosity of 200 SUS at 54° C (130° F). Performance data is typical. Actual data may vary slightly from one production motor to another.
 Les données sur les performances sont basées sur des tests utilisant de l'huile 10W40 d'une viscosité de 200 SUS à 54°C (130°F). Ces données correspondent à des situations typiques. Les données réelles peuvent varier légèrement d'un moteur de production à l'autre.

Intermittierende Werte maximal 10% von jeder Betriebsminute.
 Capacidad de funcionamiento intermitente valida para 6 segundos por cada minuto.
 Leistungsdaten sind gemessen mit SAE 10W40 bei einer Viskosität von 43,1 Cst bei 54°C. Geringfügige Abweichungen von den Katalogdaten sind möglich.
 Datos tecnicos obtenidos con aceite 10W40 de 200 SUS de viscosidad a 54°C (130°F). Los datos proporcionados son valores típicos. Los valores exactos reales podrían tener una pequeña variación entre distintos motores.

■ Cont. □ Int.

TB 0050

3.0 cu in / rev PRESSURE (PSID)

	500	1000	1500	1800	2000	2400
.5	144 26	319 13				
1	154 65	338 50	518 35	625 28	697 21	840 9
2	163 141	360 127	555 110	671 102	746 94	875 80
3	161 218	358 203	557 186	675 177	753 169	907 153
4	160 295	361 279	567 261	691 251	774 243	931 227
5	155 371	358 355	566 337	693 326	777 317	946 301
7	143 525	346 507	558 487	686 474	772 466	946 448
9	133 678	336 658	546 638	675 623	761 614	936 595

Flow (GPM)

TORQUE (LB IN) 675
 SPEED (RPM) 623

49 cc / rev

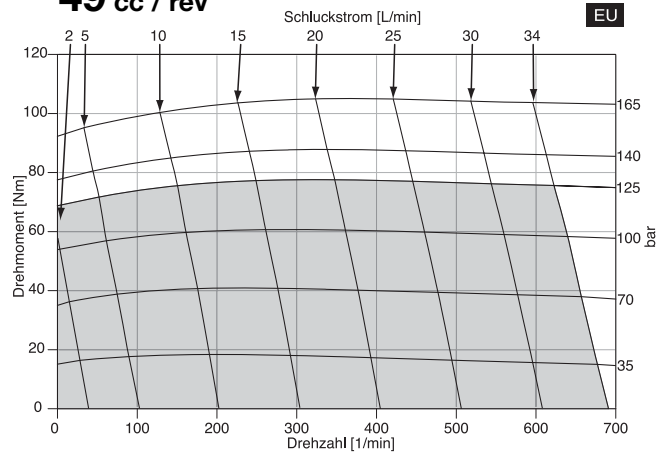

TB 0065

4.0 cu in / rev PRESSURE (PSID)

	500	1000	1500	1800	2000	2400
.5	213 22	459 14	709 6			
1	224 51	479 42	734 34	887 29	989 25	1193 17
2	233 108	500 99	767 90	926 85	1033 81	1228 71
3	231 166	498 156	769 147	932 141	1039 136	1252 126
4	229 224	501 214	778 203	945 197	1056 192	1272 181
5	223 281	497 271	777 260	946 252	1058 247	1284 237
7	206 396	481 385	764 372	936 364	1050 359	1280 347
9	192 511	467 499	749 485	920 476	1035 470	1267 457

Flow (GPM)

TORQUE (LB IN) 920
 SPEED (RPM) 476

65 cc / rev

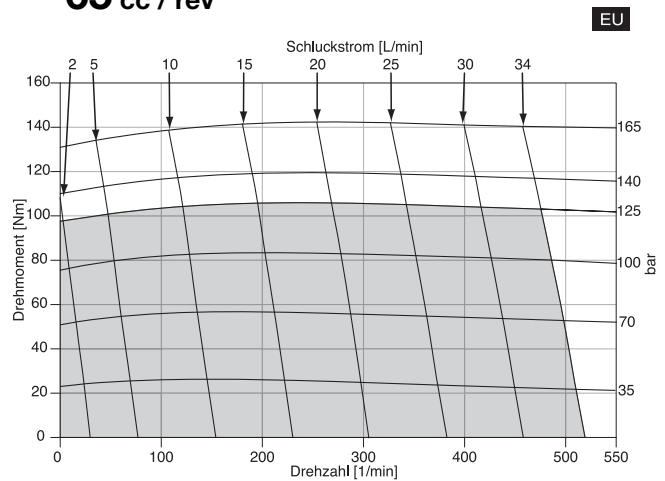

Intermittent operation rating applies to 10% of every minute.

Fonctionnement interm. 10% max. de chaque minute d'utilisation.

Performance data based on testing using 10W40 oil with a viscosity of 200 SUS at 54° C (130° F). Performance data is typical. Actual data may vary slightly from one production motor to another.

Les données sur les performances sont basées sur des tests utilisant de l'huile 10W40 d'une viscosité de 200 SUS à 54°C (130°F). Ces données correspondent à des situations typiques. Les données réelles peuvent varier légèrement d'un moteur de production à l'autre.

Intermittierende Werte maximal 10% von jeder Betriebsminute.

Capacidad de funcionamiento intermitente valida para 6 segundos por cada minuto.

Leistungsdaten sind gemessen mit SAE 10W40 bei einer Viskosität von 43,1 Cst bei 54°C. Geringfügige Abweichungen von den Katalogdaten sind möglich.

Datos tecnicos obtenidos con aceite 10W40 de 200 SUS de viscosidad a 54°C (130°F). Los datos proporcionados son valores tipicos. Los valores exactos reales podrian tener una pequena variacion entre distintos motores.

■ Cont. □ Int.

TB 0080

5.0 cu in / rev PRESSURE (PSID)

	500	1000	1500	1800	2000	2400
.5	256 17	562 10	877 4			
1	269 40	585 33	905 26	1097 21	1226 18	1487 10
2	285 86	616 78	950 70	1150 66	1283 62	1527 53
3	285 132	619 124	959 116	1163 110	1298 106	1566 97
4	286 178	628 170	976 161	1187 155	1327 151	1600 141
5	282 225	627 216	979 206	1193 200	1335 196	1621 185
7	267 317	615 307	972 296	1189 290	1333 285	1624 274
9	252 409	600 398	956 387	1173 379	1318 374	1609 362

Flow (GPM)

TORQUE (LB IN) 1173
SPEED (RPM) 379

82 cc / rev

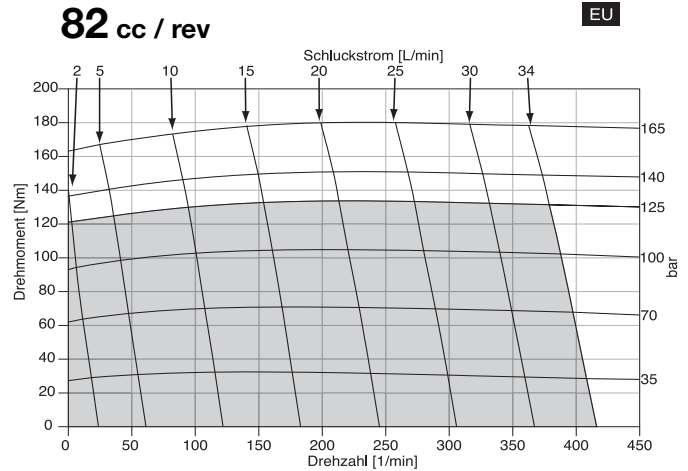

TB 0100

6.0 cu in / rev PRESSURE (PSID)

	500	1000	1500	1800	2000	2400
.5	310 16	669 13	1035 9	1258 7	1408 5	
1	330 35	697 32	1073 27	1298 25	1448 23	1737 18
2	346 73	732 69	1121 64	1353 61	1509 59	1800 53
3	345 111	735 107	1134 102	1371 98	1530 95	1844 89
4	347 149	747 144	1158 139	1403 135	1569 132	1885 126
5	343 187	750 182	1164 176	1411 172	1578 169	1909 162
7	327 264	738 257	1159 250	1411 246	1580 242	1917 235
9	301 340	715 333	1139 325	1395 319	1566 316	1909 307
12	257 454	669 446	1091 437	1347 430	1518 426	1863 417

Flow (GPM)

TORQUE (LB IN) 1347
SPEED (RPM) 430

98 cc / rev

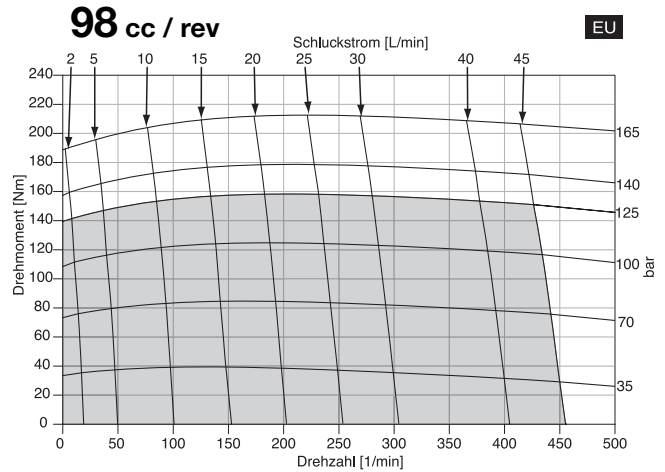

Intermittent operation rating applies to 10% of every minute.
Fonctionnement intermitt. 10% max. de chaque minute d'utilisation.
Performance data based on testing using 10W40 oil with a viscosity of 200 SUS at 54° C (130° F). Performance data is typical. Actual data may vary slightly from one production motor to another.
Les données sur les performances sont basées sur des tests utilisant de l'huile 10W40 d'une viscosité de 200 SUS à 54°C (130°F). Ces données correspondent à des situations typiques. Les données réelles peuvent varier légèrement d'un moteur de production à l'autre.

Intermittierende Werte maximal 10% von jeder Betriebsminute.
Capacidad de funcionamiento intermitente valida para 6 segundos por cada minuto.
Leistungsdaten sind gemessen mit SAE 10W40 bei einer Viskosität von 43,1 Cst bei 54°C. Geringfügige Abweichungen von den Katalogdaten sind möglich.
Datos tecnicos obtenidos con aceite 10W40 de 200 SUS de viscosidad a 54°C (130°F). Los datos proporcionados son valores típicos. Los valores exactos reales podrían tener una pequeña variación entre distintos motores.

■ Cont. □ Int.

TB 0130

8.0 cu in / rev PRESSURE (PSID)

	500	1000	1500	1800	2000	2400
.5	446 12	955 10	1479 7	1797 5	2011 3	
1	465 27	989 24	1515 21	1831 19	2043 17	2469 13
2	481 55	1023 52	1571 49	1901 46	2120 44	2520 40
3	482 84	1029 81	1581 77	1912 74	2133 72	2570 67
4	483 113	1042 109	1605 105	1940 102	2164 100	2608 95
5	478 142	1041 138	1610 133	1951 130	2179 128	2628 122
7	450 199	1019 195	1597 190	1943 186	2174 184	2632 177
9	414 257	984 252	1563 246	1911 242	2145 239	2612 233
12	335 343	907 338	1489 331	1842 327	2076 323	2550 316
15	253 430	818 424	1393 416	1740 411	1974 407	2443 399

Flow (GPM)

TORQUE (LB IN) 2612
SPEED (RPM) 233

130 cc / rev

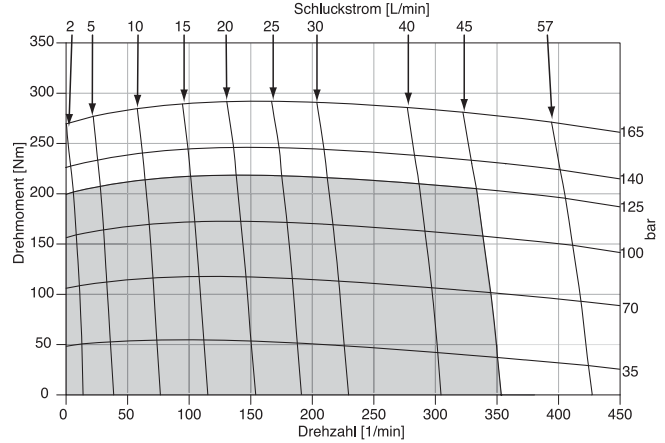

TB 0165

10.0 cu in / rev PRESSURE (PSID)

	500	1000	1500	1800	2250
.5	529 9	1137 7	1769 4	2149 3	
1	556 21	1181 18	1819 15	2201 13	2776 9
2	580 44	1238 40	1909 37	2314 34	2876 29
3	584 67	1248 63	1926 59	2332 56	2934 51
4	592 90	1276 86	1968 82	2382 78	3000 73
5	588 113	1283 109	1988 104	2412 101	3046 95
7	560 159	1268 154	1987 149	2418 145	3062 139
9	517 205	1230 200	1957 194	2393 190	3047 183
12	425 274	1141 268	1874 262	2317 257	2980 250
15	321 343	1033 337	1759 330	2197 325	2859 317

Flow (GPM)

TORQUE (LB IN) 3047
SPEED (RPM) 183

163 cc / rev

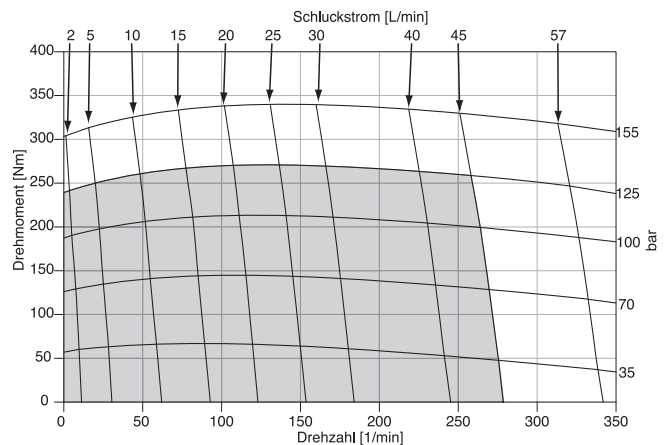

■ Cont. □ Int.

Intermittent operation rating applies to 10% of every minute.

Fonctionnement interm. 10% max. de chaque minute d'utilisation.

Performance data based on testing using 10W40 oil with a viscosity of 200 SUS at 54° C (130° F). Performance data is typical. Actual data may vary slightly from one production motor to another.

Les donnees sur les performances sont basees sur des tests utilisant de l'huile 10W40 d'une viscosite de 200 SUS a 54°C (130°F). Ces donnees correspondent a des situations typiques. Les donnees reelles peuvent varier legerement d'un moteur de production a l'autre.

Intermittierende Werte maximal 10% von jeder Betriebsminute.

Capacidad de funcionamiento intermitente valida para 6 segundos por cada minuto.

Leistungsdaten sind gemessen mit SAE 10W40 bei einer Viskosität von 43,1 Cst bei 54°C. Geringfügige Abweichungen von den Katalogdaten sind möglich.

Datos tecnicos obtenidos con aceite 10W40 de 200 SUS de viscosidad a 54°C (130°F). Los datos proporcionados son valores tipicos. Los valores exactos reales podrian tener una pequena variacion entre distintos motores.

TB 0195

11.9 cu in / rev PRESSURE (PSID)

	500	1000	1500	1800	2100
.5	688 9	1490 8	2329 7	2841 6	3353 5
1	718 18	1537 17	2380 16	2890 15	3373 14
2	746 38	1580 36	2443 35	2962 33	3442 32
3	745 57	1592 55	2452 53	2973 52	3494 50
4	746 76	1607 74	2482 72	3008 71	3528 69
5	737 95	1601 93	2480 91	3011 89	3537 87
7	697 134	1572 131	2455 129	2986 127	3514 125
9	641 172	1510 169	2398 167	2934 164	3472 162
12	530 230	1391 227	2283 223	2821 221	3360 217
15	399 287	1252 284	2130 280	2662 277	3200 273

Flow (GPM)

TORQUE (LB IN) 3472
SPEED (RPM) 162

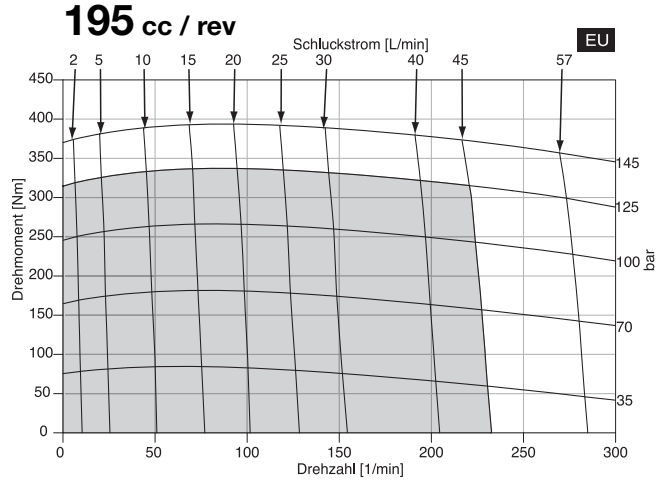

TB 0230

13.9 cu in / rev PRESSURE (PSID)

	500	1000	1500	2000
.5	796 8	1704 7	2640 6	3597 5
1	818 16	1733 15	2681 14	3623 13
2	840 32	1775 31	2732 30	3700 28
3	845 49	1789 47	2750 46	3725 43
4	848 65	1815 64	2789 62	3762 59
5	840 82	1813 80	2797 78	3782 74
7	799 114	1790 112	2785 110	3776 106
9	741 147	1738 145	2738 142	3741 138
12	613 197	1615 194	2626 190	3645 185
15	473 246	1531 243	2457 239	3467 233

Flow (GPM)

TORQUE (LB IN) 3776
SPEED (RPM) 106

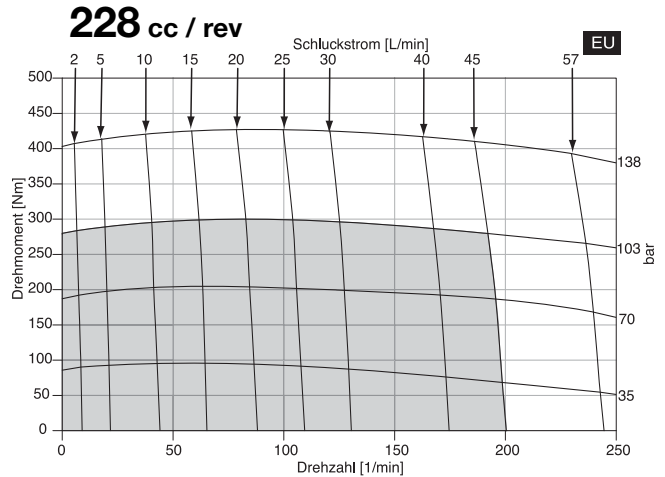

Cont. Int.

Intermittent operation rating applies to 10% of every minute.
 Fonctionnement intermitt. 10% max. de chaque minute d'utilisation.
 Performance data based on testing using 10W40 oil with a viscosity of 200 SUS at 54° C (130° F). Performance data is typical. Actual data may vary slightly from one production motor to another.
 Les données sur les performances sont basées sur des tests utilisant de l'huile 10W40 d'une viscosité de 200 SUS à 54°C (130°F). Ces données correspondent à des situations typiques. Les données réelles peuvent varier légèrement d'un moteur de production à l'autre.

Intermittierende Werte maximal 10% von jeder Betriebsminute.
 Capacidad de funcionamiento intermitente valida para 6 segundos por cada minuto.
 Leistungsdaten sind gemessen mit SAE 10W40 bei einer Viskosität von 43,1 Cst bei 54°C. Geringfügige Abweichungen von den Katalogdaten sind möglich.
 Datos tecnicos obtenidos con aceite 10W40 de 200 SUS de viscosidad a 54°C (130°F). Los datos proporcionados son valores típicos. Los valores exactos reales podrían tener una pequeña variación entre distintos motores.

TB 0260

15.9 cu in / rev PRESSURE (PSID)

	500	1000	1450	1900
.5	906 7	1947 6	2910 5	3896 4
1	932 14	1984 13	2964 12	3919 11
2	958 28	2032 27	3025 26	4000 24
3	961 43	2047 41	3045 40	4052 38
4	963 57	2074 56	3086 54	4098 52
5	954 71	2074 70	3096 68	4117 65
7	909 100	2049 99	3084 96	4112 93
9	844 129	1991 127	3032 125	4070 121
12	696 172	1851 170	2903 167	3953 162
15	540 216	1683 213	2711 209	3753 204

TORQUE (LB IN) 4112
SPEED (RPM) 93

Flow (GPM)

TB 0295

17.9 cu in / rev PRESSURE (PSID)

	500	1000	1400	1800
.5	1039 6	2229 5	3208 4	4200 3
1	1069 12	2281 11	3265 10	4248 9
2	1098 25	2332 24	3337 22	4290 20
3	1100 38	2344 36	3353 35	4356 32
4	1098 50	2366 49	3386 47	4398 44
5	1086 63	2361 61	3391 60	4415 57
7	1034 89	2325 87	3361 85	4394 81
9	955 114	2250 112	3295 109	4337 106
12	792 153	2085 150	3141 147	4194 142
15	606 191	1879 188	2908 185	3955 180

TORQUE (LB IN) 4337
SPEED (RPM) 106

Flow (GPM)

260 cc / rev

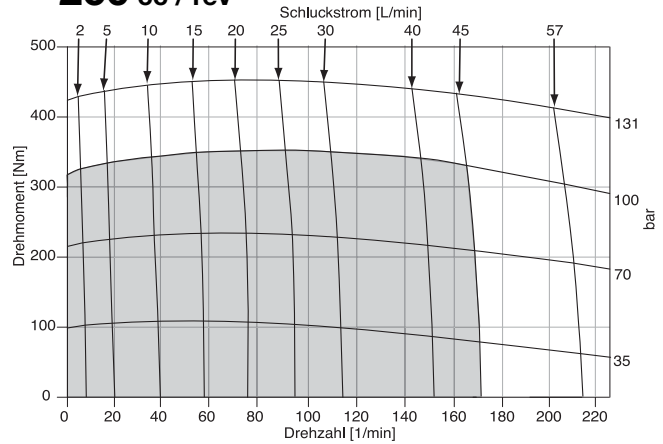

293 cc / rev

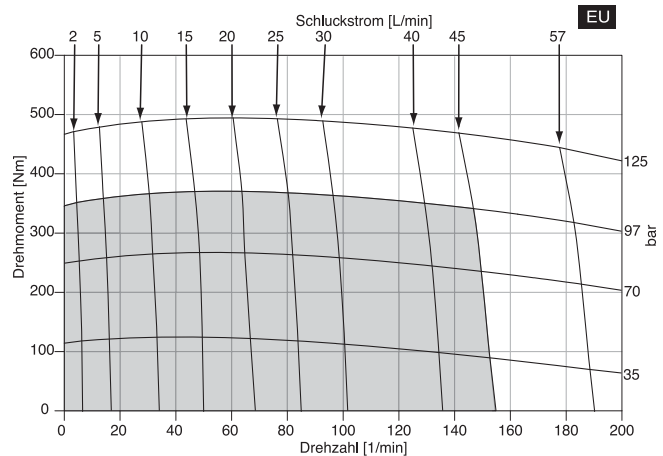

■ Cont. □ Int.

Intermittent operation rating applies to 10% of every minute.

Fonctionnement interm. 10% max. de chaque minute d'utilisation.

Performance data based on testing using 10W40 oil with a viscosity of 200 SUS at 54° C (130° F). Performance data is typical. Actual data may vary slightly from one production motor to another.

Les données sur les performances sont basées sur des tests utilisant de l'huile 10W40 d'une viscosité de 200 SUS à 54°C (130°F). Ces données correspondent à des situations typiques. Les données réelles peuvent varier légèrement d'un moteur de production à l'autre.

Intermittierende Werte maximal 10% von jeder Betriebsminute.

Capacidad de funcionamiento intermitente valida para 6 segundos por cada minuto.

Leistungsdaten sind gemessen mit SAE 10W40 bei einer Viskosität von 43,1 Cst bei 54°C. Geringfügige Abweichungen von den Katalogdaten sind möglich.

Datos tecnicos obtenidos con aceite 10W40 de 200 SUS de viscosidad a 54°C (130°F). Los datos proporcionados son valores tipicos. Los valores exactos reales podrian tener una pequena variacion entre distintos motores.

TB 0330

20.0 cu in / rev PRESSURE (PSID)

	500	1000	1350	1650
.5	1192 5	2498 4	3425 4	4227 3
1	1224 11	2555 10	3495 9	4250 8
2	1255 22	2620 21	3581 20	4350 18
3	1259 34	2633 32	3597 31	4424 29
4	1258 45	2666 43	3645 42	4480 40
5	1243 56	2665 55	3657 53	4505 51
7	1186 79	2627 77	3634 75	4492 73
9	1092 102	2544 100	3563 97	4431 94
12	905 137	2363 134	3391 131	4269 127
15	692 171	2129 168	3136 165	4001 161

Flow (GPM)

TORQUE (LB IN) 4431
SPEED (RPM) 94

328 cc / rev

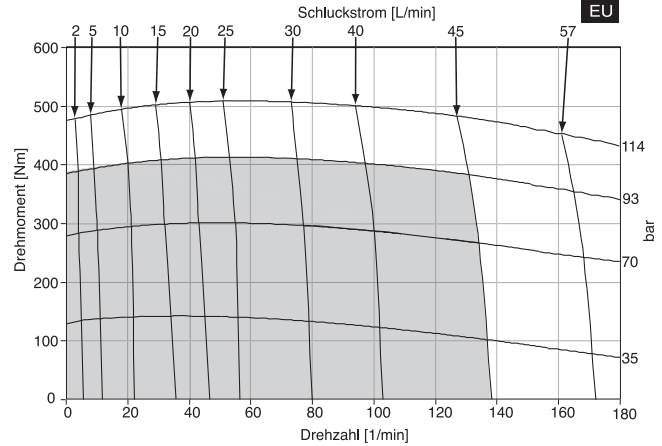

TB 0365

22.6 cu in / rev PRESSURE (PSID)

	500	1000	1250	1525
.5	1393 5	2942 4	3734 4	4617 3
1	1444 10	3005 9	3796 9	4672 8
2	1494 20	3090 19	3890 18	4710 17
3	1485 30	3082 29	3883 28	4765 27
4	1477 40	3089 39	3897 38	4783 36
5	1452 50	3075 49	3887 48	4775 46
7	1371 70	3009 69	3826 67	4719 65
9	1260 90	2899 89	3721 87	4621 85
12	1002 121	2658 119	3488 117	4393 115
15	700 151	2355 149	3190 147	4095 144

Flow (GPM)

TORQUE (LB IN) 4621
SPEED (RPM) 85

370 cc / rev

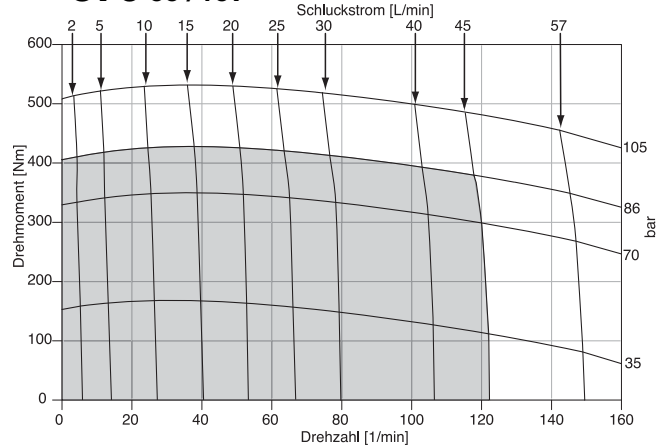

■ Cont. □ Int.

Intermittent operation rating applies to 10% of every minute.
Fonctionnement interm. 10% max. de chaque minute d'utilisation.
Performance data based on testing using 10W40 oil with a viscosity of 200 SUS at 54° C (130° F). Performance data is typical. Actual data may vary slightly from one production motor to another.
Les donnees sur les performances sont basees sur des tests utilisant de l'huile 10W40 d'une viscosite de 200 SUS a 54°C (130°F). Ces donnees correspondent a des situations typiques. Les donnees reelles peuvent varier legerement d'un moteur de production a l'autre.

Intermittierende Werte maximal 10% von jeder Betriebsminute.
Capacidad de funcionamiento intermitente valida para 6 segundos por cada minuto.
Leistungsdaten sind gemessen mit SAE 10W40 bei einer Viskositat von 43,1 Cst bei 54°C. Geringfuegige Abweichungen von den Katalogdaten sind moeglich.
Datos tecnicos obtenidos con aceite 10W40 de 200 SUS de viscosidad a 54°C (130°F). Los datos proporcionados son valores tipicos. Los valores exactos reales podrian tener una pequena variacion entre distintos motores.

TB 0390

24.0 cu in / rev PRESSURE (PSID)

	500	1000	1200	1450
.5	1309 4	2885 3	3534 2	4359 2
1	1368 9	2948 8	3589 7	4394 6
2	1417 18	3028 17	3683 16	4460 15
3	1427 28	3058 26	3714 26	4540 24
4	1443 37	3102 36	3764 35	4595 34
5	1439 47	3120 45	3790 45	4630 43
7	1392 66	3110 65	3792 64	4642 62
9	1297 85	3040 84	3732 83	4597 81
12	1087 114	2835 112	3541 111	4418 110
15	831 143	2571 141	3272 140	4145 138

Flow (GPM)

TORQUE (LB IN) 4597
SPEED (RPM) 81

392 cc / rev

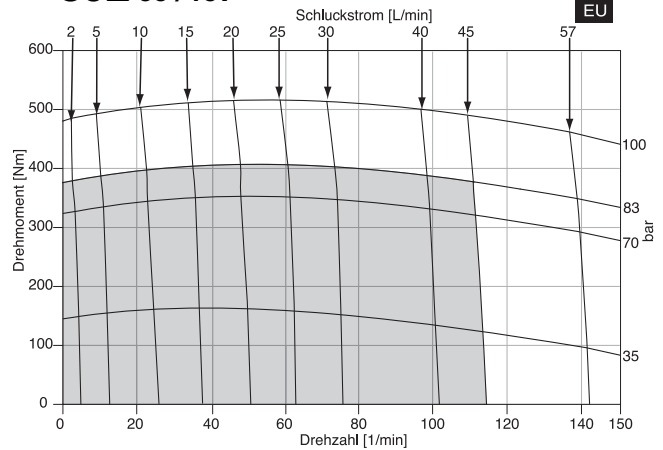

Cont. Int.

Intermittent operation rating applies to 10% of every minute.

Fonctionnement interm. 10% max. de chaque minute d'utilisation.

Performance data based on testing using 10W40 oil with a viscosity of 200 SUS at 54° C (130° F). Performance data is typical. Actual data may vary slightly from one production motor to another.

Les donnees sur les performances sont basees sur des tests utilisant de l'huile 10W40 d'une viscosite de 200 SUS a 54°C (130°F). Ces donnees correspondent a des situations typiques. Les donnees reelles peuvent varier legerement d'un moteur de production a l'autre.

Intermittierende Werte maximal 10% von jeder Betriebsminute.

Capacidad de funcionamiento intermitente valida para 6 segundos por cada minuto.

Leistungsdaten sind gemessen mit SAE 10W40 bei einer Viskosität von 43,1 Cst bei 54°C. Geringfügige Abweichungen von den Katalogdaten sind möglich.

Datos tecnicos obtenidos con aceite 10W40 de 200 SUS de viscosidad a 54°C (130°F). Los datos proporcionados son valores tipicos. Los valores exactos reales podrian tener una pequena variacion entre distintos motores.

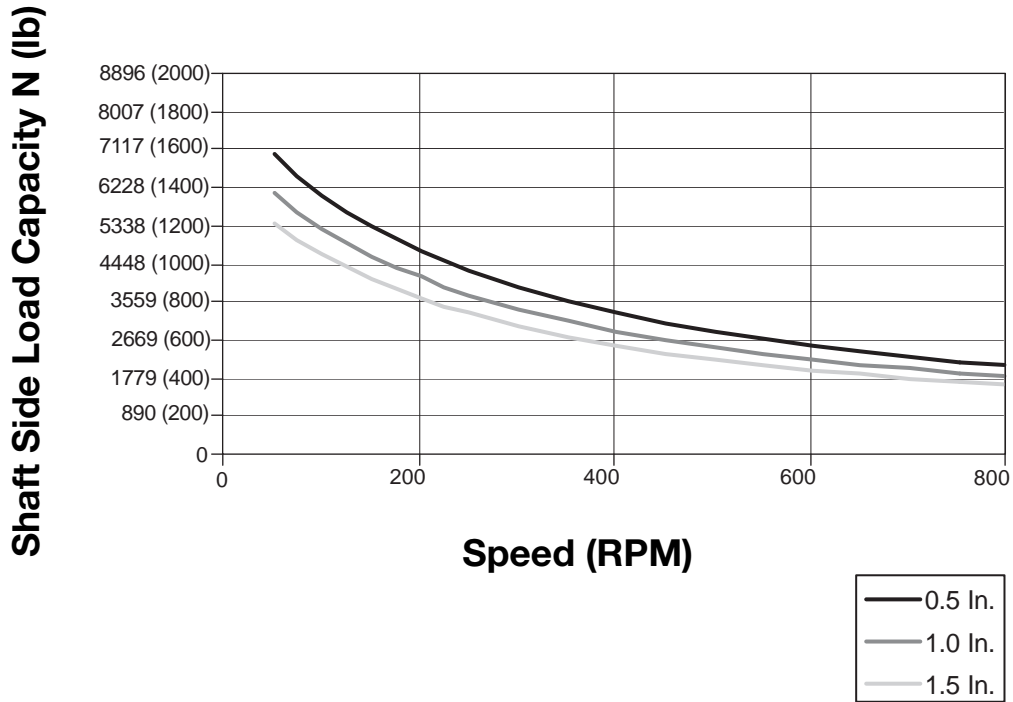

The allowable side load curve is based on bushing life of 2.5×10^6 revolutions.
 Die zulaessige radiale Wellenbelastung bezieht sich auf die Lager-Lebensdauer $2,5 \times 10^6$ Umdrehungen.
 L'effort radial admissible sur l'arbre depend a une duree de vie $2,5 \times 10^6$ de rotation.
 La curva de carga lateral admisible se basa en vida util de cojinete de 2.5×10 revoluciones.

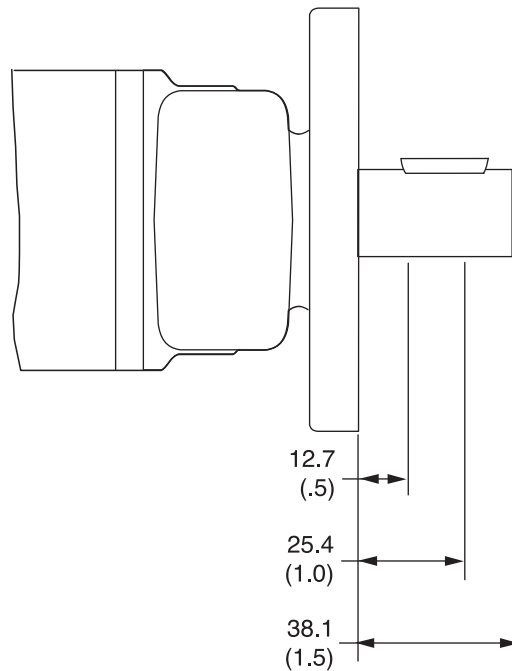

English equivalents for metric specifications are shown in ().

Code: AM

**SAE A 2-Bolt,
5/16-18 UNC
Manifold**

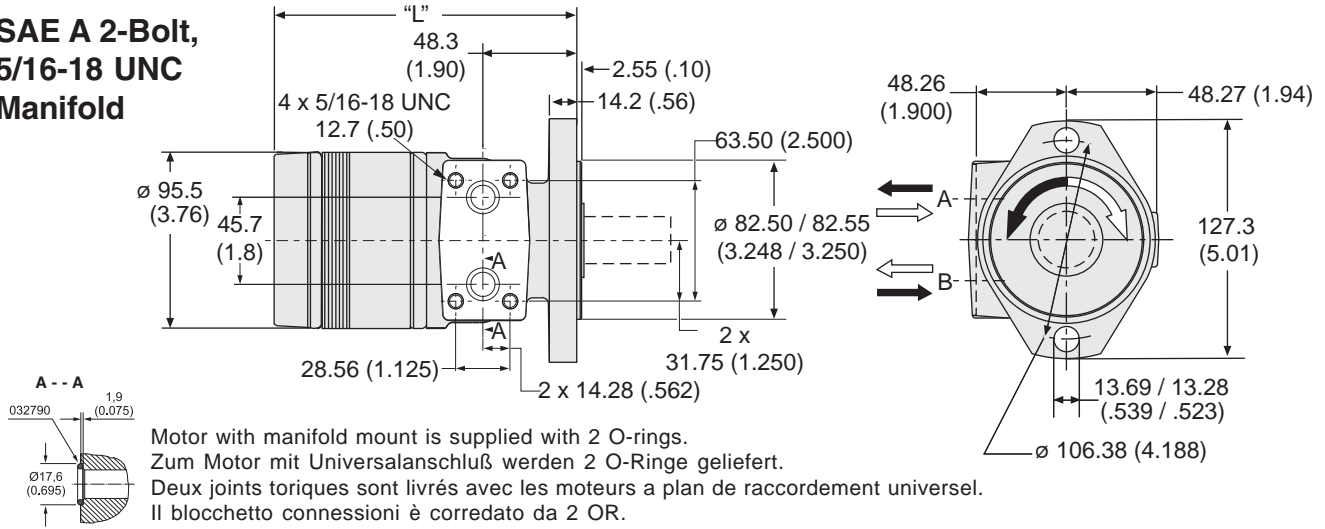

Code AM disp.	0036	0045	0050	0065	0080	0100	0130	0165	0195	0230	0260	0295	0330	0365	0390
Weight/Gewicht kg	5.87	6.03	6.12	6.26	6.35	6.49	6.76	7.03	7.35	7.58	7.80	8.07	8.35	8.66	8.80
Poids/Peso (lb)	(12.9)	(13.3)	(13.5)	(13.8)	(14.0)	(14.3)	(14.9)	(15.5)	(16.2)	(16.7)	(17.2)	(17.8)	(18.4)	(19.1)	(19.4)
Length "L" mm	132.4	136	138	141	144	147	154	160	166	173	179	185	192	200	205
"L" (in)	(5.22)	(5.36)	(5.42)	(5.54)	(5.67)	(5.79)	(6.04)	(6.29)	(6.54)	6.79	7.04	7.29	7.54	7.88	8.04

Code: AP

**SAE A 2-Bolt,
1/2-14 NPTF**

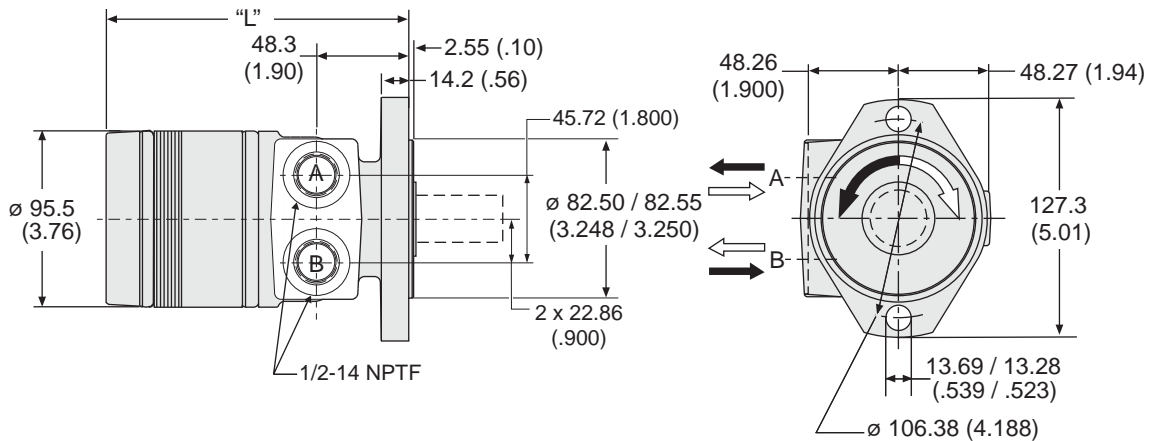

Code AP disp.	0036	0045	0050	0065	0080	0100	0130	0165	0195	0230	0260	0295	0330	0365	0390
Weight/Gewicht kg	5.87	6.03	6.12	6.26	6.35	6.49	6.76	7.03	7.35	7.58	7.80	8.07	8.35	8.66	8.80
Poids/Peso (lb)	(12.9)	(13.3)	(13.5)	(13.8)	(14.0)	(14.3)	(14.9)	(15.5)	(16.2)	(16.7)	(17.2)	(17.8)	(18.4)	(19.1)	(19.4)
Length "L" mm	132.4	136	138	141	144	147	154	160	166	173	179	185	192	200	205
"L" (in)	(5.22)	(5.36)	(5.42)	(5.54)	(5.67)	(5.79)	(6.04)	(6.29)	(6.54)	6.79	7.04	7.29	7.54	7.88	8.04

English equivalents for metric specifications are shown in ().

Code: AS

**SAE A 2-Bolt,
 7/8"-14 SAE
 O-Ring**

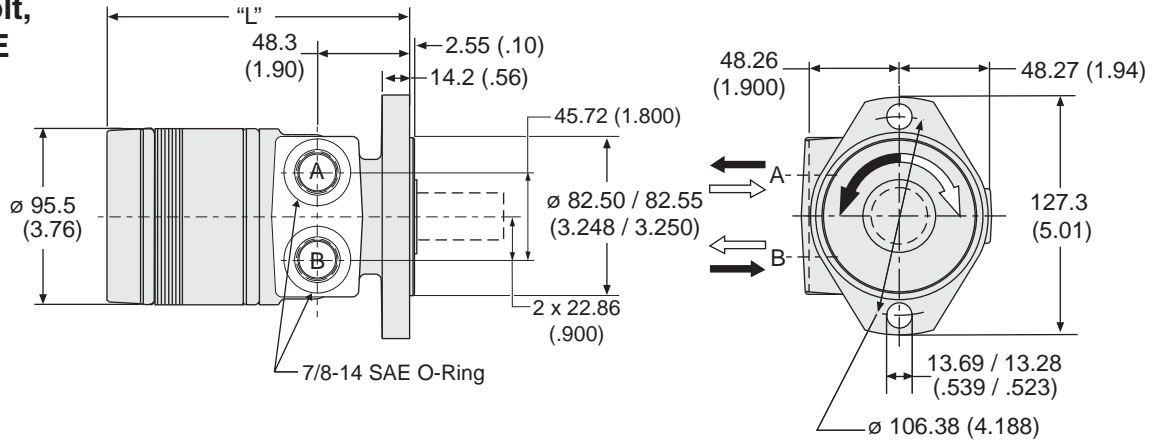

Code AS disp.	0036	0045	0050	0065	0080	0100	0130	0165	0195	0230	0260	0295	0330	0365	0390
Weight/Gewicht kg	5.87	6.03	6.12	6.26	6.35	6.49	6.76	7.03	7.35	7.58	7.80	8.07	8.35	8.66	8.80
Poids/Peso (lb)	(12.9)	(13.3)	(13.5)	(13.8)	(14.0)	(14.3)	(14.9)	(15.5)	(16.2)	(16.7)	(17.2)	(17.8)	(18.4)	(19.1)	(19.4)
Length "L" mm	132.4	136	138	141	144	147	154	160	166	173	179	185	192	200	205
"L" (in)	(5.22)	(5.36)	(5.42)	(5.54)	(5.67)	(5.79)	(6.04)	(6.29)	(6.54)	6.79	7.04	7.29	7.54	7.88	8.04

Code: FM

**4-Bolt,
 5/16-18 UNC
 Manifold**

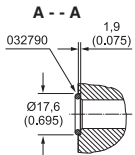
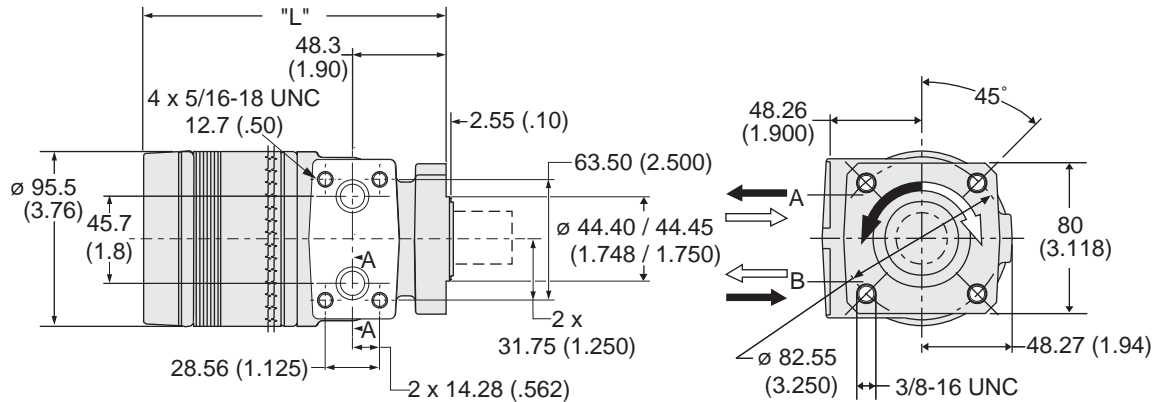

Motor with manifold mount is supplied with 2 O-rings.
 Zum Motor mit Universalanschlusß werden 2 O-Ringe geliefert.
 Deux joints toriques sont livrés avec les moteurs a plan de raccordement universel.
 Il blocchetto connessioni è corredato da 2 OR.

Code FM disp.	0036	0045	0050	0065	0080	0100	0130	0165	0195	0230	0260	0295	0330	0365	0390
Weight/Gewicht kg	5.58	5.62	5.67	5.80	5.94	6.08	6.31	6.62	7.03	7.17	7.39	7.62	7.94	8.26	8.39
Poids/Peso (lb)	(12.3)	(12.4)	(12.5)	(12.8)	(13.1)	(13.4)	(13.9)	(14.6)	(15.5)	(15.8)	(16.3)	(16.8)	(17.5)	(18.2)	(18.5)
Length "L" mm	132.4	136	138	141	144	147	154	160	166	173	179	185	192	200	205
"L" (in)	(5.22)	(5.36)	(5.42)	(5.54)	(5.67)	(5.79)	(6.04)	(6.29)	(6.54)	(6.79)	(7.04)	(7.29)	(7.54)	(7.88)	(8.04)

English equivalents for metric specifications are shown in ().

Code: FP

**4 Bolt,
1/2-14 NPTF**

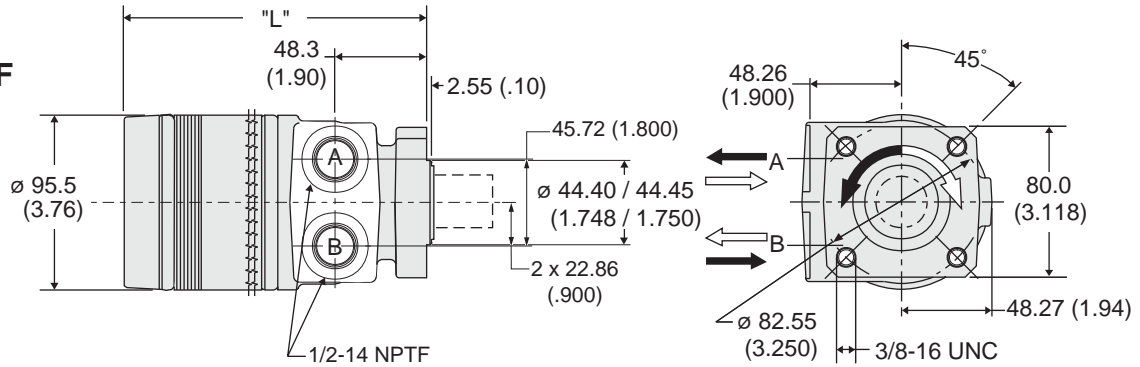

Code FP disp.	0036	0045	0050	0065	0080	0100	0130	0165	0195	0230	0260	0295	0330	0365	0390
Weight/Gewicht kg	5.58	5.62	5.67	5.80	5.94	6.08	6.31	6.62	7.03	7.17	7.39	7.62	7.94	8.26	8.39
Poids/Peso (lb)	(12.3)	(12.4)	(12.5)	(12.8)	(13.1)	(13.4)	(13.9)	(14.6)	(15.5)	(15.8)	(16.3)	(16.8)	(17.5)	(18.2)	(18.5)
Length"L" mm	132.4	136	138	141	144	147	154	160	166	173	179	185	192	200	205
"L" (in)	(5.22)	(5.36)	(5.42)	(5.54)	(5.67)	(5.79)	(6.04)	(6.29)	(6.54)	(6.79)	(7.04)	(7.29)	(7.54)	(7.88)	(8.04)

Code: FS

**4 Bolt,
7/8"-14 SAE
O-Ring**

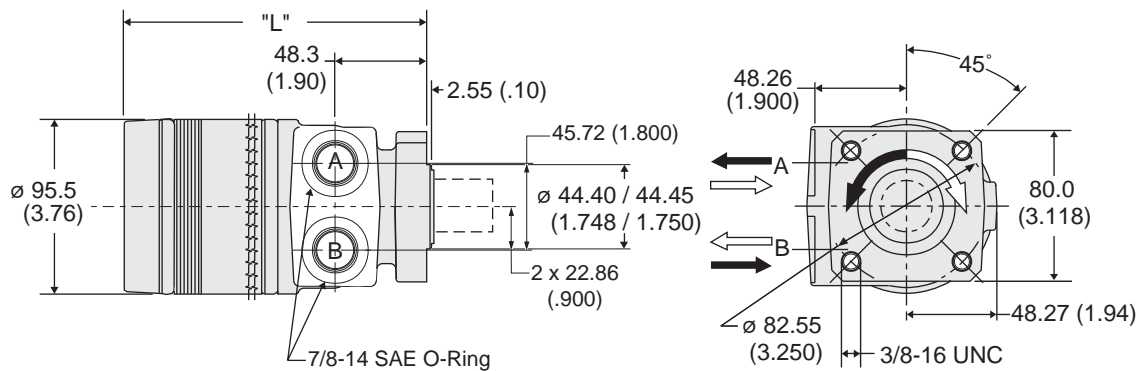

Code FS disp.	0036	0045	0050	0065	0080	0100	0130	0165	0195	0230	0260	0295	0330	0365	0390
Weight/Gewicht kg	5.58	5.62	5.67	5.80	5.94	6.08	6.31	6.62	7.03	7.17	7.39	7.62	7.94	8.26	8.39
Poids/Peso (lb)	(12.3)	(12.4)	(12.5)	(12.8)	(13.1)	(13.4)	(13.9)	(14.6)	(15.5)	(15.8)	(16.3)	(16.8)	(17.5)	(18.2)	(18.5)
Length"L" mm	132.4	136	138	141	144	147	154	160	166	173	179	185	192	200	205
"L" (in)	(5.22)	(5.36)	(5.42)	(5.54)	(5.67)	(5.79)	(6.04)	(6.29)	(6.54)	(6.79)	(7.04)	(7.29)	(7.54)	(7.88)	(8.04)

English equivalents for metric specifications are shown in ().

Code: BS
SAE B 2-Bolt
7/8-14 SAE

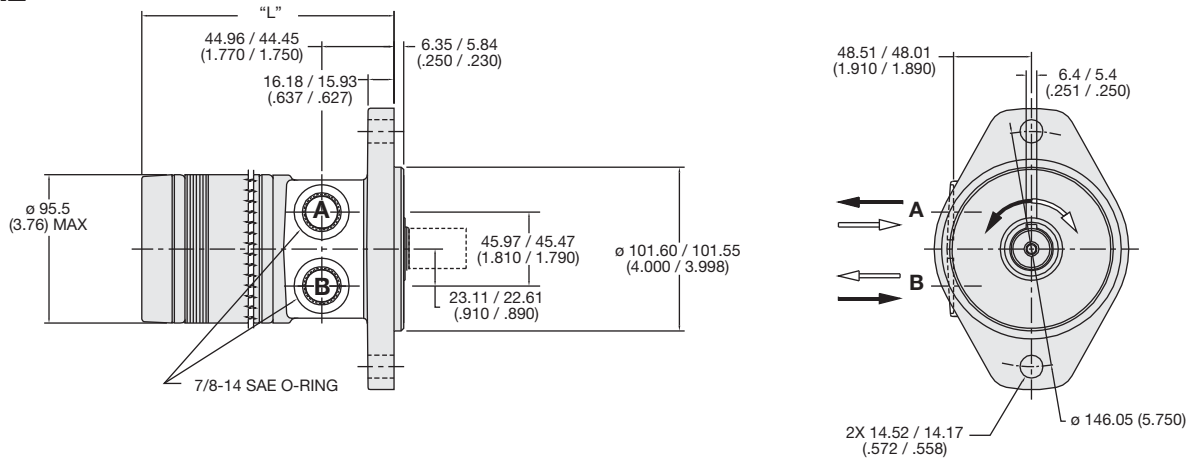

Code BS disp.	0036	0045	0050	0065	0080	0100	0130	0165	0195	0230	0260	0295	0330	0365	0390
Weight/Gewicht kg	7.27	7.34	7.48	7.62	7.71	7.84	8.11	8.39	8.70	8.93	9.16	9.43	9.70	9.97	10.1
Poids/Peso (lb)	(15.9)	(16.3)	(16.5)	(16.8)	(17.0)	(17.3)	(17.9)	(18.5)	(19.2)	(19.7)	(20.2)	(20.8)	(21.4)	(22.0)	(22.4)
Length "L" mm	131.5	132.5	134.1	137.1	140.4	143.5	149.8	156.2	162.5	168.9	175.2	181.6	187.9	196.5	200.9
"L" (in)	(5.18)	(5.22)	(5.28)	(5.40)	(5.53)	(5.65)	(5.90)	(6.15)	(6.40)	(6.65)	(6.90)	(7.15)	(7.40)	(7.74)	(7.91)

Code: CM
SAE A 2 Bolt, Long Pilot
5/16-18 UNC Manifold

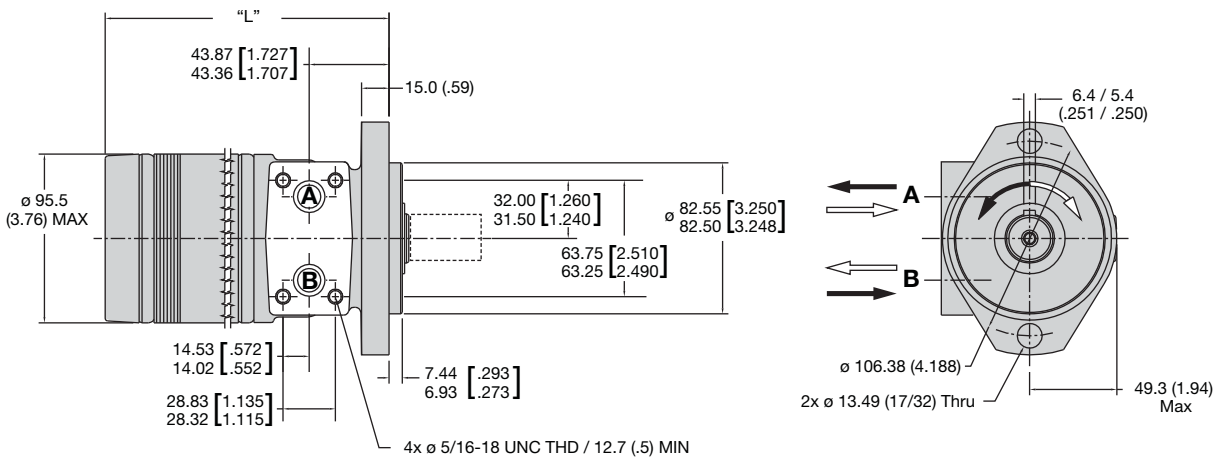

Code CM disp.	0036	0045	0050	0065	0080	0100	0130	0165	0195	0230	0260	0295	0330	0365	0390
Weight/Gewicht kg	6.17	6.35	6.44	6.58	6.67	6.80	7.07	7.35	7.66	7.84	8.11	8.39	8.66	8.94	9.11
Poids/Peso (lb)	(13.6)	(14.0)	(14.2)	(14.5)	(14.7)	(15.0)	(15.6)	(16.2)	(16.9)	(17.4)	(17.9)	(18.5)	(19.1)	(19.7)	(20.1)
Length "L" mm	130.4	131.5	132.9	136.1	139.3	142.5	148.8	155.2	161.5	167.9	174.2	180.6	186.9	195.6	199.7
"L" (in)	(5.13)	(5.18)	(5.23)	(5.36)	(5.48)	(5.61)	(5.86)	(6.11)	(6.36)	(6.61)	(6.86)	(7.11)	(7.36)	(7.70)	(7.86)

English equivalents for metric specifications are shown in ().

Code: MS
Magneto
7/8-14 SAE

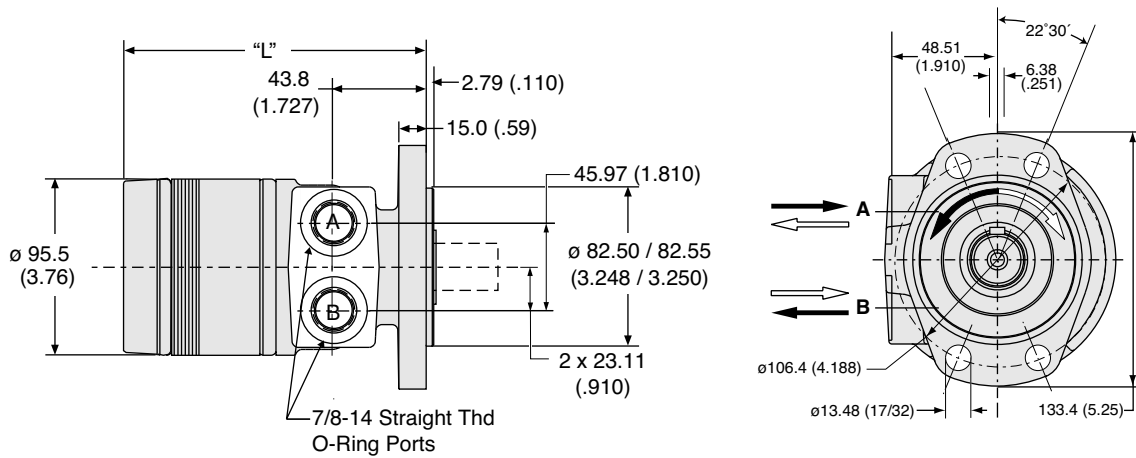

Code MS	disp.	0036	0045	0050	0065	0080	0100	0130	0165	0195	0230	0260	0295	0330	0365	0390
Weight/Gewicht	kg	6.16	6.30	6.40	6.53	6.62	6.76	7.03	7.30	7.62	7.85	8.12	8.35	8.62	8.94	9.07
Poids/Peso	(lb)	(13.6)	(13.9)	(14.1)	(14.4)	(14.6)	(14.9)	(15.5)	(16.1)	(16.8)	(17.3)	(17.9)	(18.4)	(19.0)	(19.7)	(20.0)
Length	"L" mm	135.1	136.1	137.6	140.8	144.0	147.1	153.5	159.8	166.2	172.5	178.9	185.2	191.6	200.2	204.3
	"L" (in)	(5.32)	(5.36)	(5.42)	(5.54)	(5.67)	(5.79)	(6.04)	(6.29)	(6.54)	(6.79)	(7.04)	(7.29)	(7.54)	(7.88)	(8.04)

Code: BP
SAE B 2-Bolt
1/2-14 NPTF

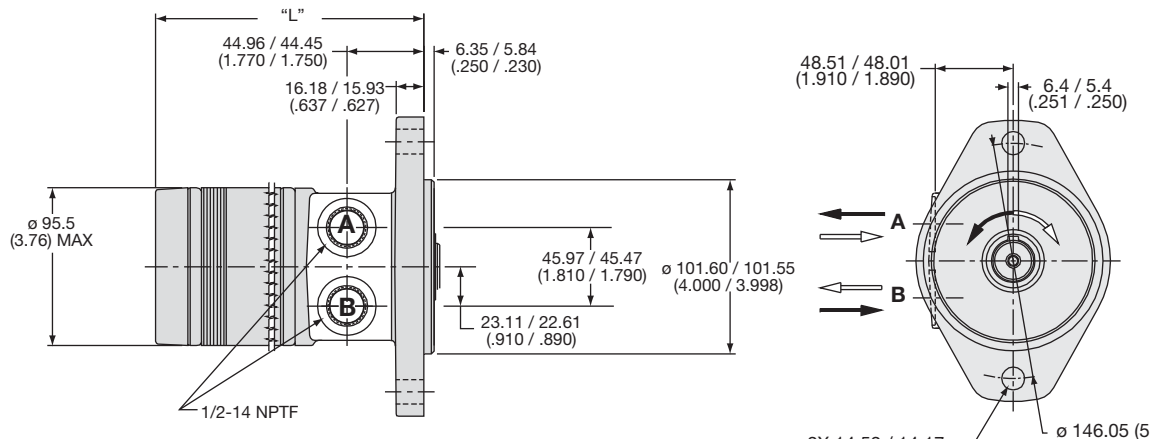

Code BP	disp.	0036	0045	0050	0065	0080	0100	0130	0165	0195	0230	0260	0295	0330	0365	0390
Weight/Gewicht	kg	7.27	7.34	7.48	7.62	7.71	7.84	8.11	8.39	8.70	8.93	9.16	9.43	9.70	9.97	10.1
Poids/Peso	(lb)	(15.9)	(16.3)	(16.5)	(16.8)	(17.0)	(17.3)	(17.9)	(18.5)	(19.2)	(19.7)	(20.2)	(20.8)	(21.4)	(22.0)	(22.4)
Length	"L" mm	131.4	132.5	134.0	137.2	140.4	143.6	149.9	156.3	162.6	169.0	175.3	181.7	188.0	196.7	200.8
	"L" (in)	(5.18)	(5.22)	(5.28)	(5.40)	(5.53)	(5.65)	(5.90)	(6.15)	(6.40)	(6.65)	(6.90)	(7.15)	(7.40)	(7.74)	(7.90)

English equivalents for metric specifications are shown in ().

Code: BM
SAE B 2-Bolt
5/16-18 UNC Manifold

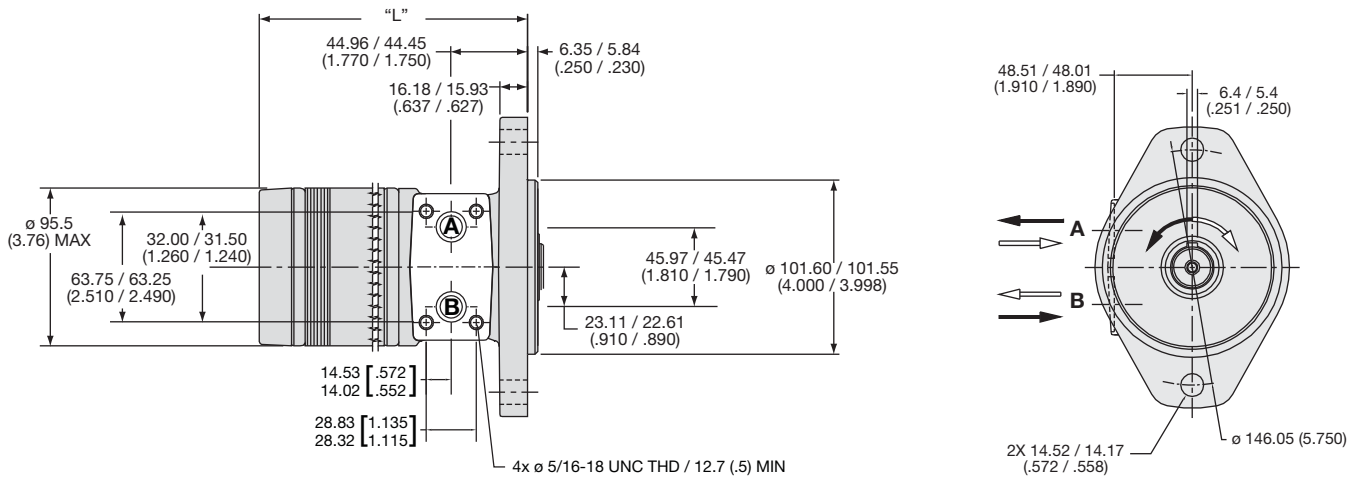

Code BM	disp.	0036	0045	0050	0065	0080	0100	0130	0165	0195	0230	0260	0295	0330	0365	0390
Weight/Gewicht	kg	7.27	7.34	7.48	7.62	7.71	7.84	8.11	8.39	8.70	8.93	9.16	9.43	9.70	9.97	10.1
Poids/Peso	(lb)	(15.9)	(16.3)	(16.5)	(16.8)	(17.0)	(17.3)	(17.9)	(18.5)	(19.2)	(19.7)	(20.2)	(20.8)	(21.4)	(22.0)	(22.4)
Length	"L" mm	131.4	132.5	134.0	137.2	140.4	143.6	149.9	156.3	162.6	169.0	175.3	181.7	188.0	196.7	200.8
	"L" (in)	(5.18)	(5.22)	(5.28)	(5.40)	(5.53)	(5.65)	(5.90)	(6.15)	(6.40)	(6.65)	(6.90)	(7.15)	(7.40)	(7.74)	(7.90)

Code: CP
SAE A 2 Bolt, Long Pilot
1/2-14 NPTF

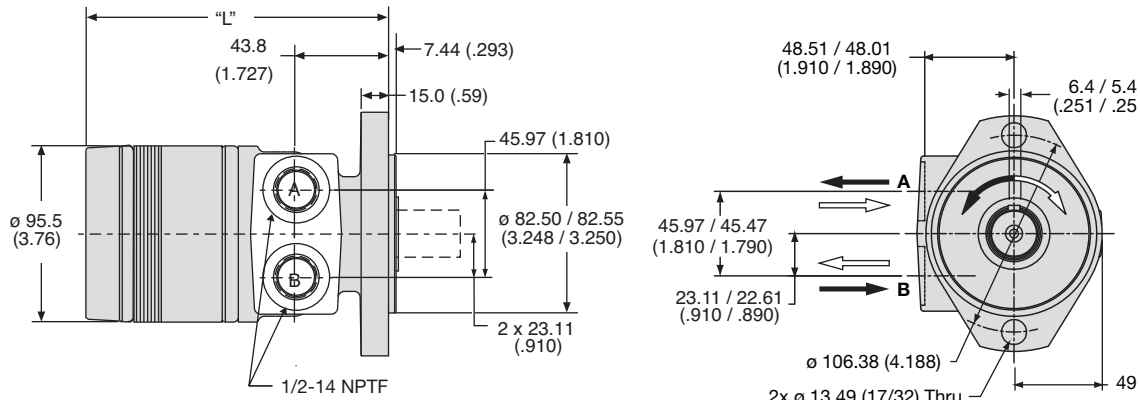

Code CP	disp.	0036	0045	0050	0065	0080	0100	0130	0165	0195	0230	0260	0295	0330	0365	0390
Weight/Gewicht	kg	6.17	6.35	6.44	6.58	6.67	6.80	7.07	7.35	7.66	7.84	8.11	8.39	8.66	8.94	9.11
Poids/Peso	(lb)	(13.6)	(14.0)	(14.2)	(14.5)	(14.7)	(15.0)	(15.6)	(16.2)	(16.9)	(17.4)	(17.9)	(18.5)	(19.1)	(19.7)	(20.1)
Length	"L" mm	130.4	131.5	132.9	136.1	139.3	142.5	148.8	155.2	161.5	167.9	174.2	180.6	186.9	195.6	199.7
	"L" (in)	(5.13)	(5.18)	(5.23)	(5.36)	(5.48)	(5.61)	(5.86)	(6.11)	(6.36)	(6.61)	(6.86)	(7.11)	(7.36)	(7.70)	(7.86)

English equivalents for metric specifications are shown in ().

Code: CS
SAE A 2 Bolt, Long Pilot
7/8-14 SAE

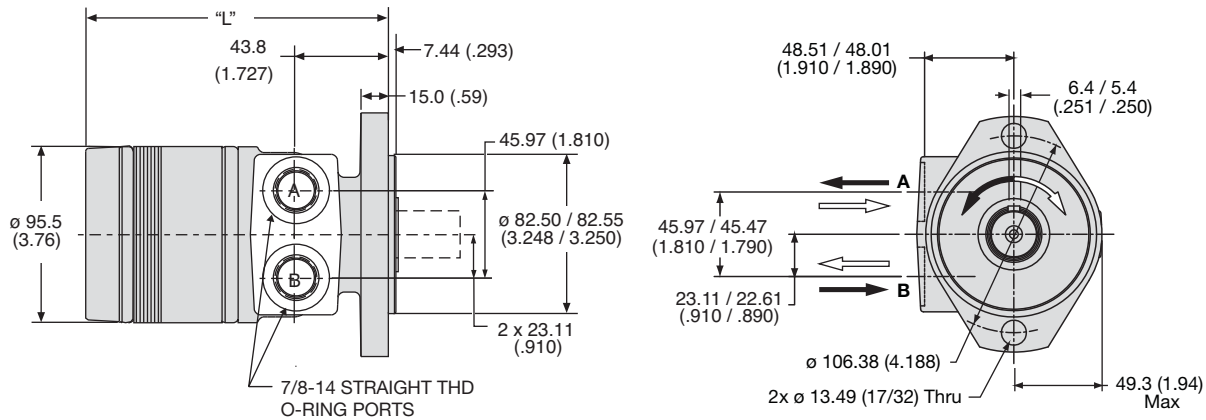

Code CS	disp.	0036	0045	0050	0065	0080	0100	0130	0165	0195	0230	0260	0295	0330	0365	0390
Weight/Gewicht	kg	6.17	6.35	6.44	6.58	6.67	6.80	7.07	7.35	7.66	7.84	8.11	8.39	8.66	8.94	9.11
Poids/Peso	(lb)	(13.6)	(14.0)	(14.2)	(14.5)	(14.7)	(15.0)	(15.6)	(16.2)	(16.9)	(17.4)	(17.9)	(18.5)	(19.1)	(19.7)	(20.1)
Length	"L" mm	130.4	131.5	132.9	136.1	139.3	142.5	148.8	155.2	161.5	167.9	174.2	180.6	186.9	195.6	199.7
	"L" (in)	(5.13)	(5.18)	(5.23)	(5.36)	(5.48)	(5.61)	(5.86)	(6.11)	(6.36)	(6.61)	(6.86)	(7.11)	(7.36)	(7.70)	(7.86)

Code: MM
Magneto
5/16-18 UNC Manifold

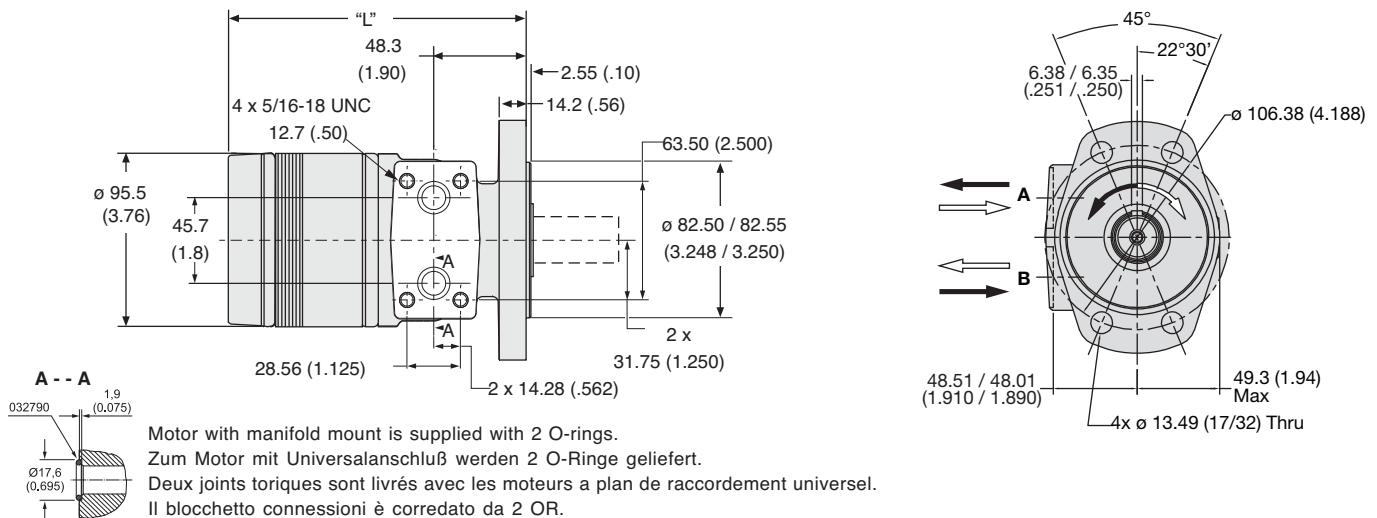

Code MM	disp.	0036	0045	0050	0065	0080	0100	0130	0165	0195	0230	0260	0295	0330	0365	0390
Weight/Gewicht	kg	6.16	6.30	6.40	6.53	6.62	6.76	7.03	7.30	7.62	7.85	8.12	8.35	8.62	8.94	9.07
Poids/Peso	(lb)	(13.6)	(13.9)	(14.1)	(14.4)	(14.6)	(14.9)	(15.5)	(16.1)	(16.8)	(17.3)	(17.9)	(18.4)	(19.0)	(19.7)	(20.0)
Length	"L" mm	135.0	136.1	137.6	140.8	144.0	147.1	153.5	159.8	166.2	172.5	178.9	185.2	191.6	200.2	204.3
	"L" (in)	(5.32)	(5.36)	(5.42)	(5.54)	(5.67)	(5.79)	(6.04)	(6.29)	(6.54)	(6.79)	(7.04)	(7.29)	(7.54)	(7.88)	(8.04)

English equivalents for metric specifications are shown in ().

Code: MP
Magneto
1/2-14 NPTF

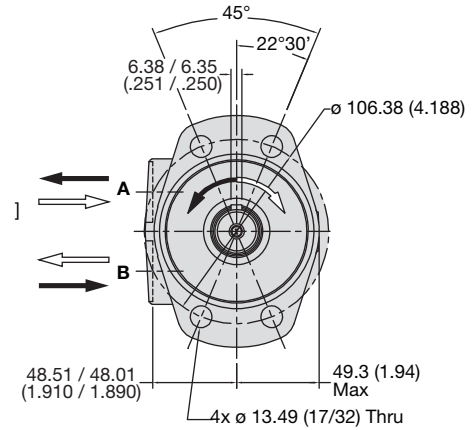
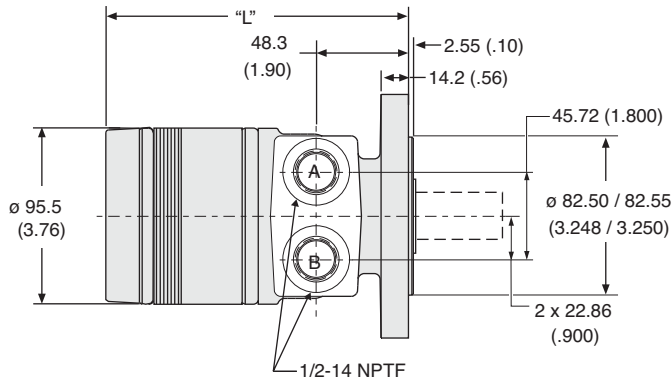

Code MP	disp.	0036	0045	0050	0065	0080	0100	0130	0165	0195	0230	0260	0295	0330	0365	0390
Weight/Gewicht	kg	6.16	6.30	6.40	6.53	6.62	6.76	7.03	7.30	7.62	7.85	8.12	8.35	8.62	8.94	9.07
Poids/Peso	(lb)	(13.6)	(13.9)	(14.1)	(14.4)	(14.6)	(14.9)	(15.5)	(16.1)	(16.8)	(17.3)	(17.9)	(18.4)	(19.0)	(19.7)	(20.0)
Length	"L" mm	135.1	136.1	137.6	140.8	144.0	147.1	153.5	159.8	166.2	172.5	178.9	185.2	191.6	200.2	204.3
	"L" (in)	(5.32)	(5.36)	(5.42)	(5.54)	(5.67)	(5.79)	(6.04)	(6.29)	(6.54)	(6.79)	(7.04)	(7.29)	(7.54)	(7.88)	(8.04)

English equivalents for metric specifications are shown in ().

002 TB.indd, js



Code: R
Rear Port
3/4"-16 SAE O-Ring

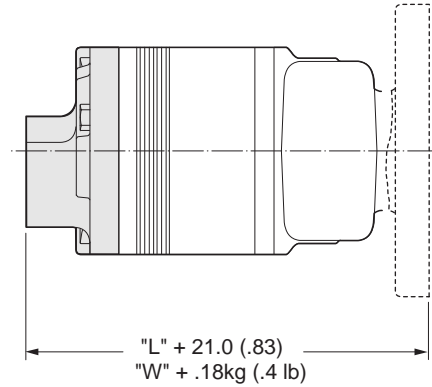
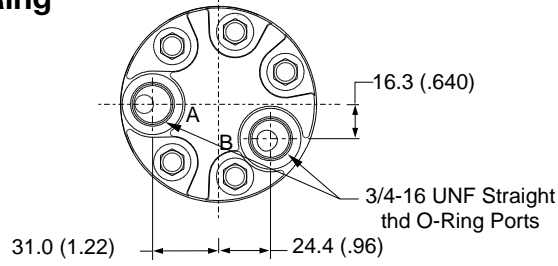

Code: Y
Rear Port
G 1/2 BSPP

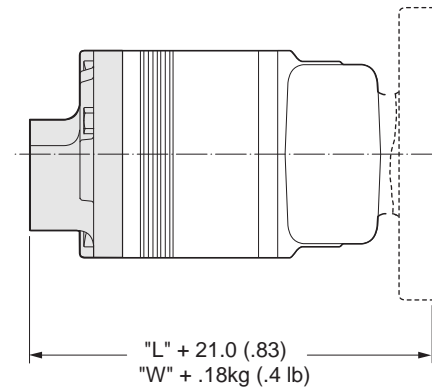
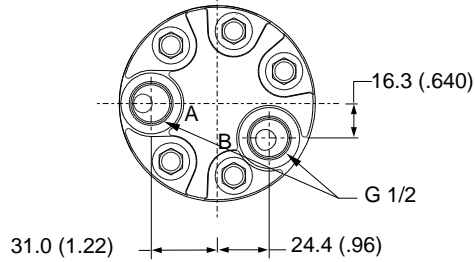

Code: S
7/8"-14 SAE O-Ring

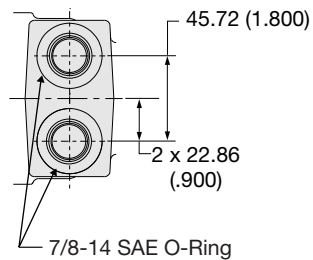

Code: P
1/2"-14 NPTF

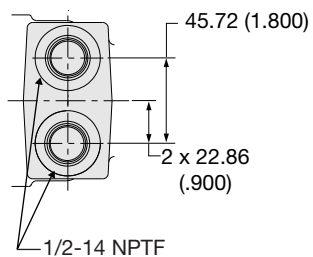

Code: M
Manifold

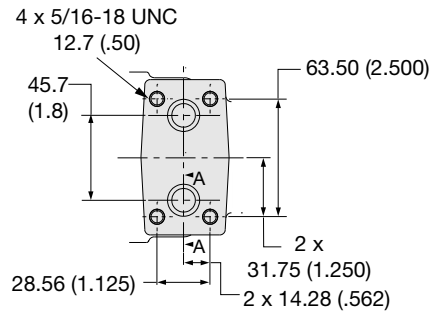

A - - A

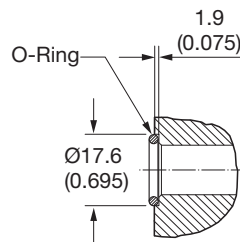

Motor with manifold mount is supplied with 2 o-rings (P/N 032790).

Zum Motor mit Universalanschluß werden 2 o-ringe geliefert.

Deux joints toriques sont livrés avec les moteurs a plan de raccordement universel.

Il blocchetto connessioni è corredato da 2 OR.

Code: W
G 1/2 BSPP
Milled Front

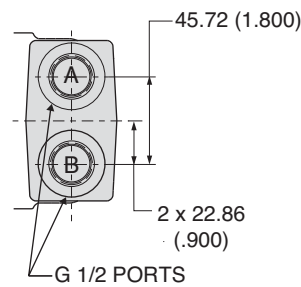

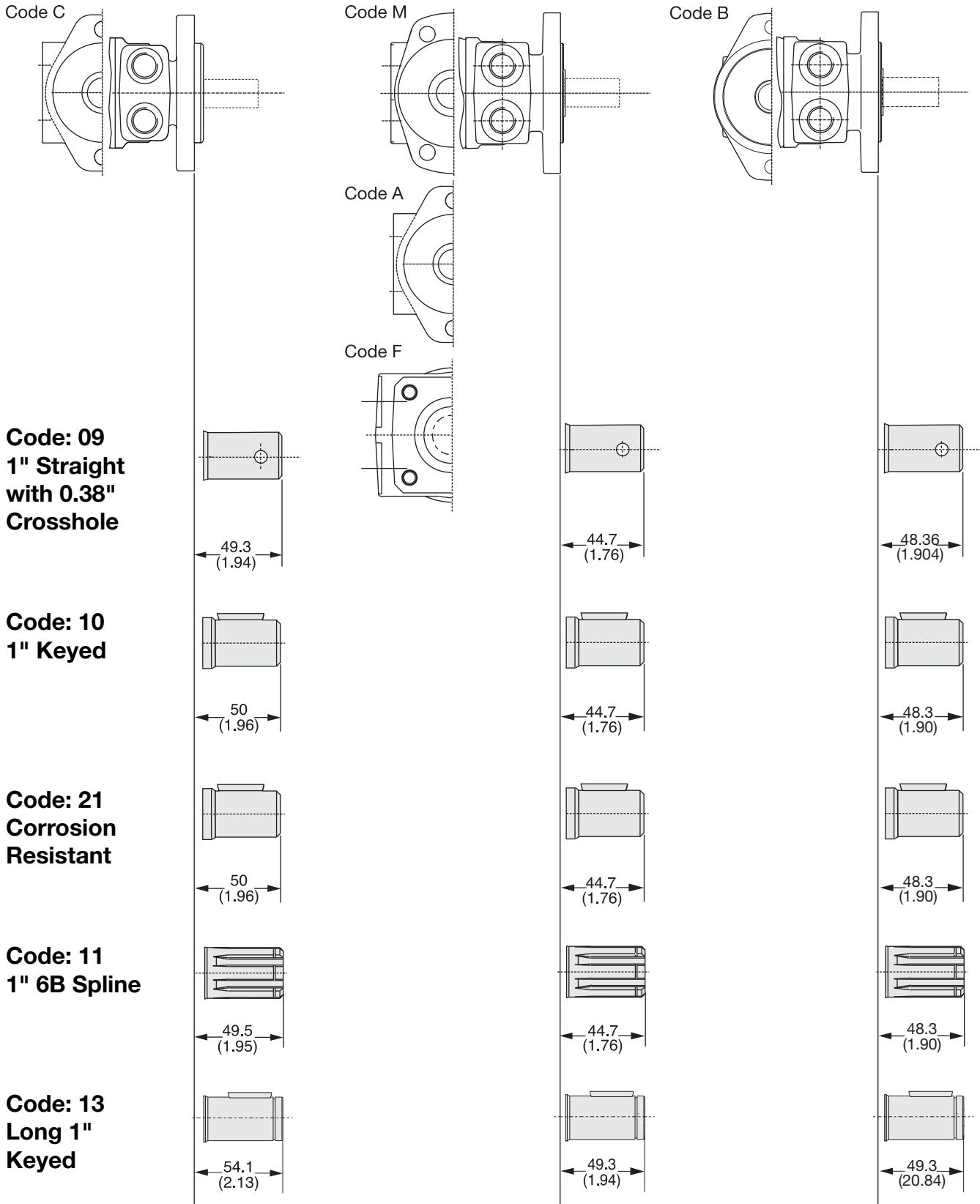

Code: 09
1" Straight
with 0.38"
Crosshole



Code: 10
1" Keyed

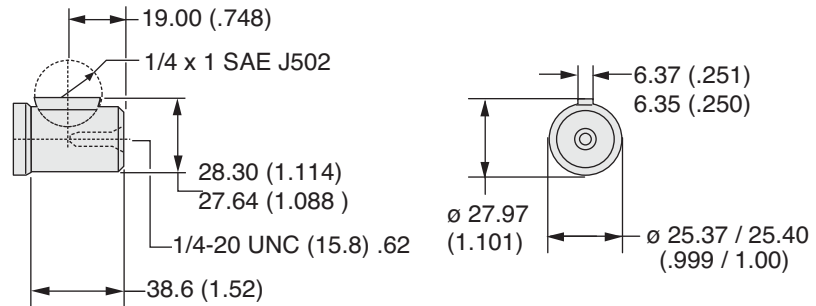

Code: 21
Corrosion
Resistant

Code: 11
1" 6B Spline

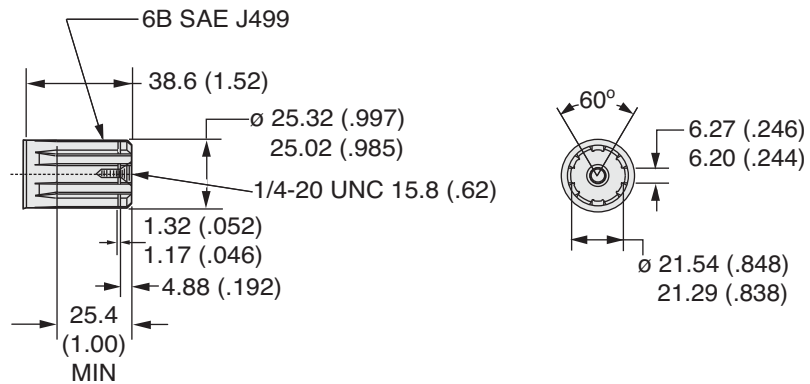

Code: 13
Long 1"
Keyed

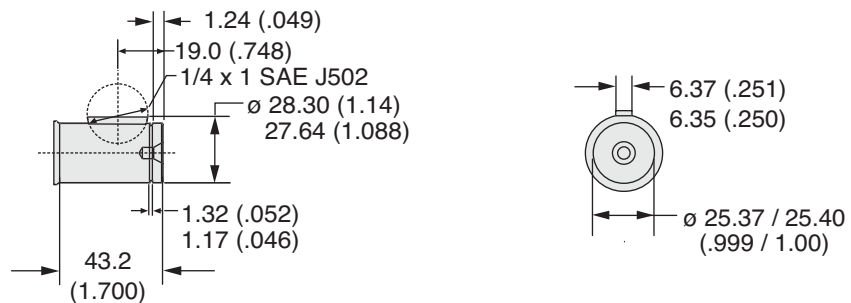

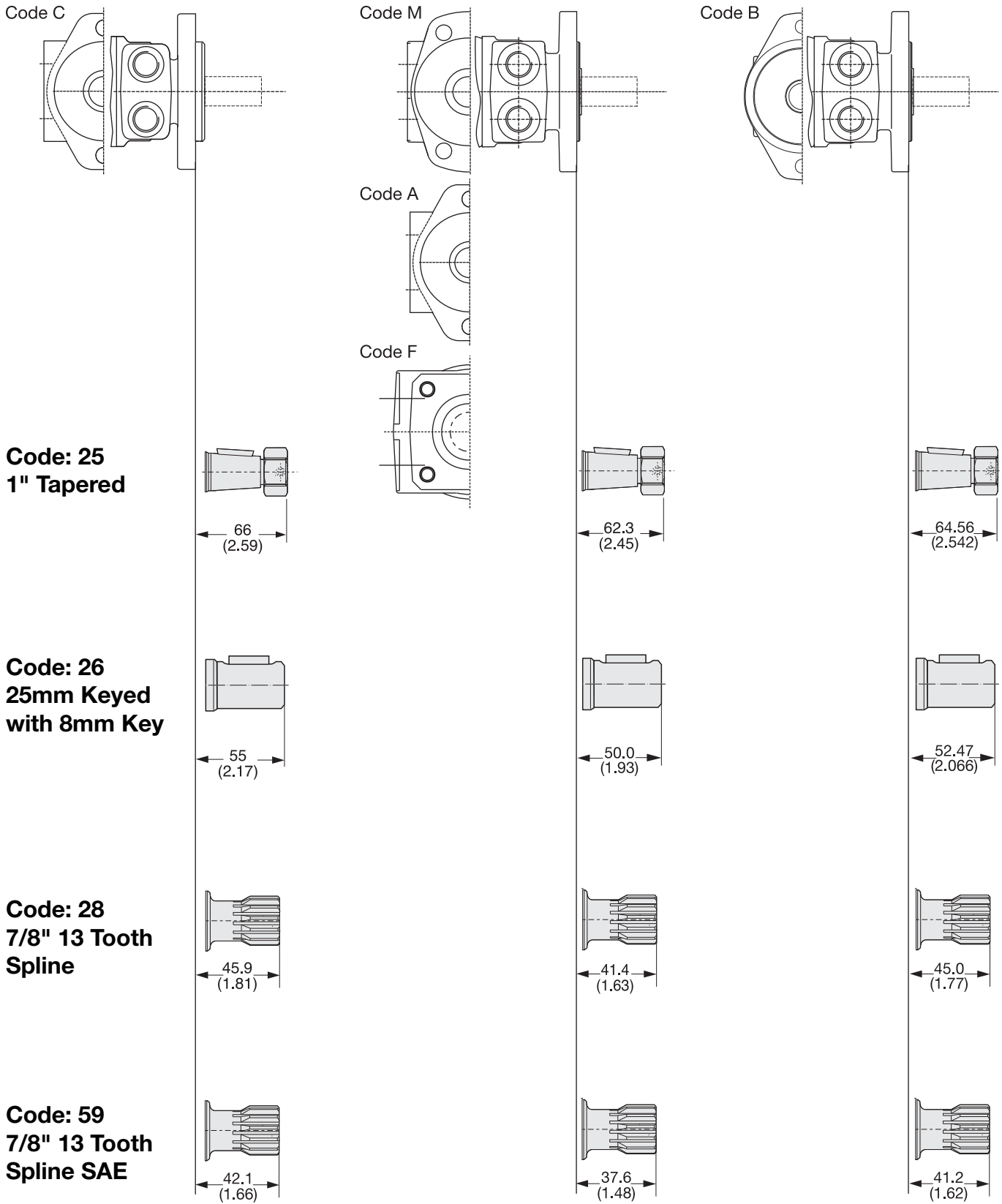

Code: 25
1" Tapered

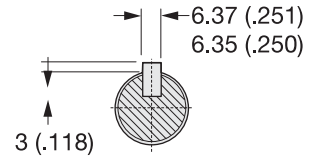
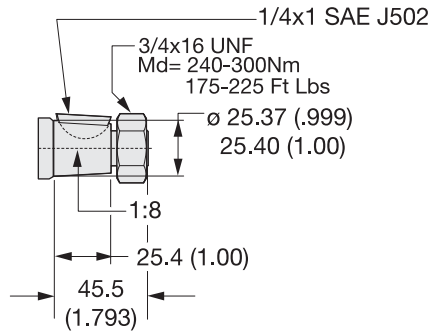

Code: 26
25mm Keyed
with 8mm Key

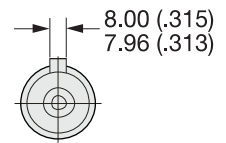
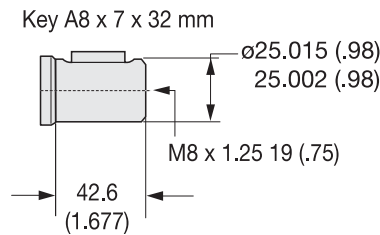

Code: 28
7/8" 13 Tooth
Spline

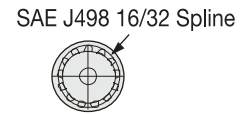
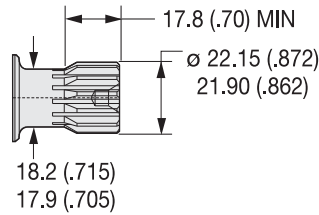

Code: 59
7/8" 13 Tooth
Spline SAE

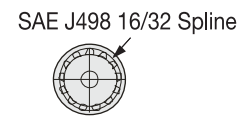
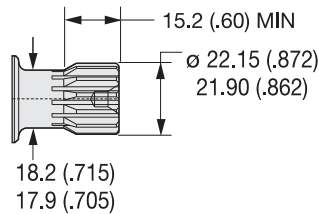

15 Displacements 15 Schluckvolumen 15 Cylindrée 15 Despazamientos	(2.2 – 24.0 in ³ /rev) 36 . . . 390 cm ³ /rev									
Maximum Pressure Eingangsdruck Chaute de pression max. Presion Maxima	<table border="1"> <thead> <tr> <th></th> <th>Cont</th> <th>Int</th> </tr> </thead> <tbody> <tr> <td></td> <td>(1800 psid)</td> <td>(2400 psid)</td> </tr> <tr> <td></td> <td>. . .125 bar</td> <td>. . .165 bar</td> </tr> </tbody> </table>		Cont	Int		(1800 psid)	(2400 psid)		. . .125 bar	. . .165 bar
	Cont	Int								
	(1800 psid)	(2400 psid)								
	. . .125 bar	. . .165 bar								
Maximum Oil Flow Schluckstrom Débit d'huile Caudal Maximo de Aceite	(15 gpm) . . . 57 lpm									
Maximum Speed Drehzahl Vitesse de rotation Velocidad Maxima	(932 rpm) 932 rpm									
Maximum Torque Max Drehmoment Couple Maxi Torque Maximo	<table border="1"> <thead> <tr> <th></th> <th>Cont</th> <th>Int</th> </tr> </thead> <tbody> <tr> <td></td> <td>(2000 lb in)</td> <td>(2000 lb in)</td> </tr> <tr> <td></td> <td>226 Nm</td> <td>226 Nm</td> </tr> </tbody> </table>		Cont	Int		(2000 lb in)	(2000 lb in)		226 Nm	226 Nm
	Cont	Int								
	(2000 lb in)	(2000 lb in)								
	226 Nm	226 Nm								
Maximum Side Load at Key Seitenlast Charges latérales Carga Maxima Lateral	(300 lb) . . . 1340 N									

A Stainless Steel Low Speed, High Torque Motor

This motor utilizes a stainless steel front housing and output shaft, with a glass filled polypropylene rear cover for the ultimate in corrosion protection. It is designed for use under water or in harsh environments where it will be exposed to water or corrosive chemicals. Features such as roller vanes, high pressure shaft seal and full flow spline lubrication are standard.

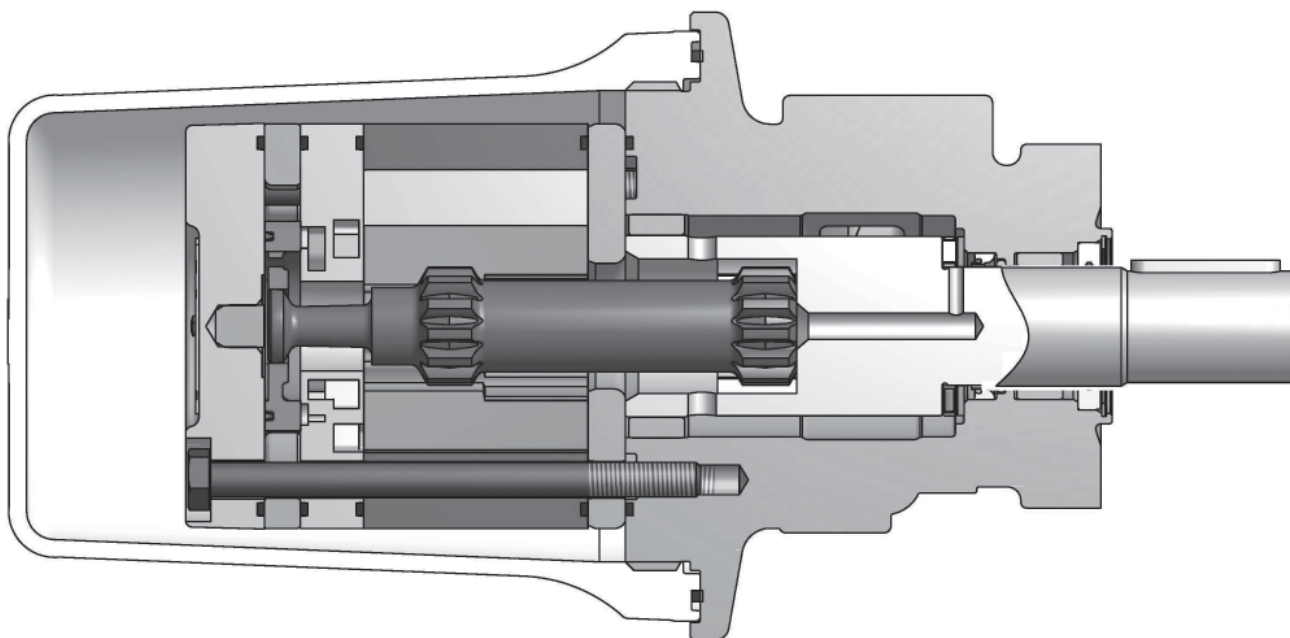

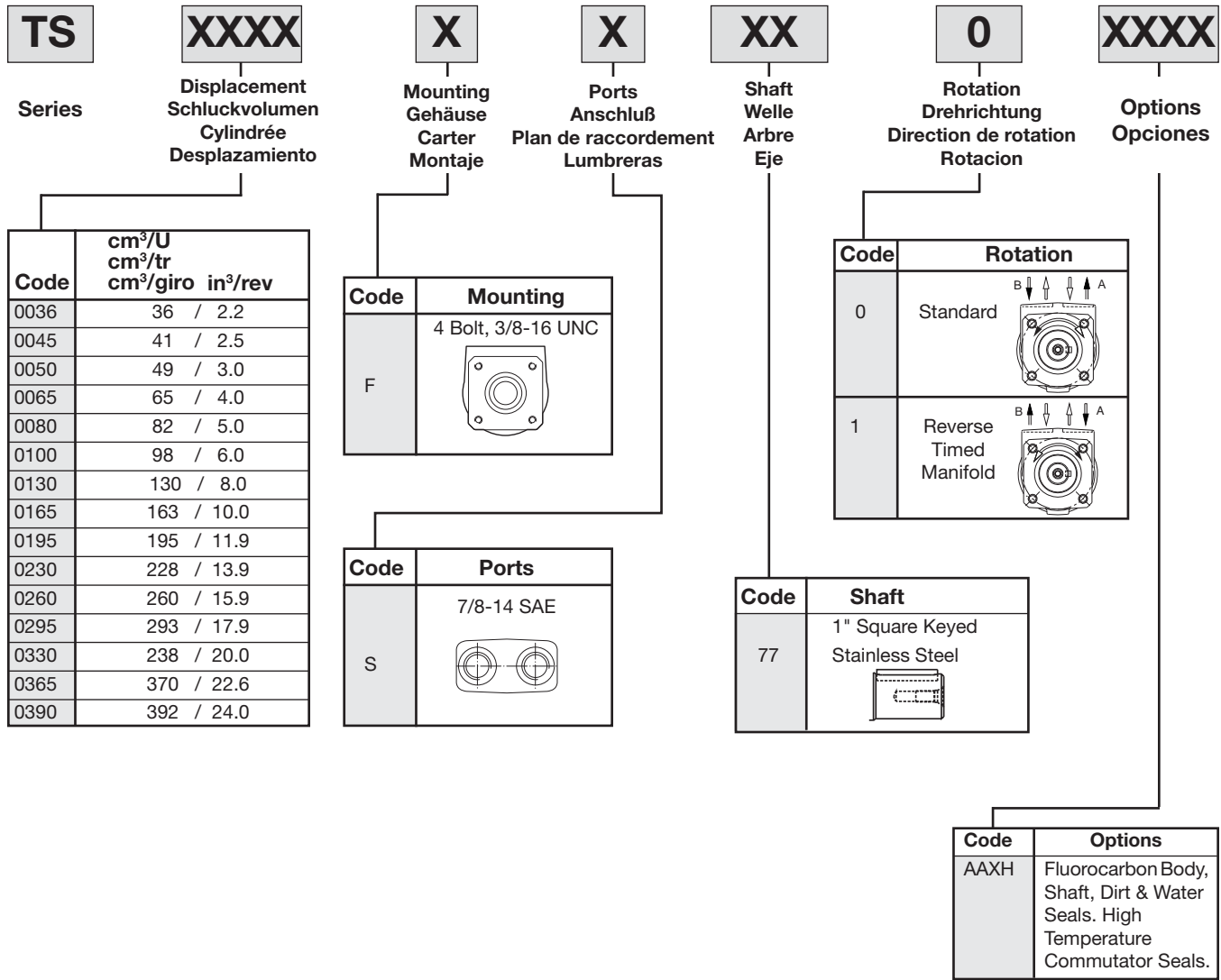

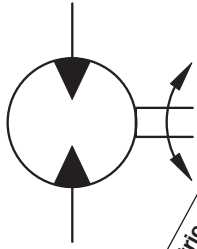

Geometric displacement
Geom. Schluckvolumen
Desplazamientos
Cylindrée
Max. speed @ Max. intermittent flow
Max. Drehzahl Intermittierender Betrieb:
Vitesse de rotation maxi
Velocidad maxima a caudal intermitente maximo
Max. oil flow
Max. Schluckstrom
Caudal Maximo
Max. Differential Pressure
Max. Druckgefälle
Chute de pression maxi
Presion diferencial maxima
Max. supply pressure
Max. Eingangsdruck
Presion maxi entrée
Presion maxima de alimentacion
Max. torque
Max. Drehmoment
Couple maxi
Torque Maximo
Max. Performance
Max. Leistungabgabe
Puissance de sortie maxi
Maximo rendimiento
Min. starting torque
Min. Anlaufmoment
Couple min. fourni au démarrage
Torque minimo de arranque

Motor Series TS	cm ³ /rev in ³ /rev	rev/min	cont / int* l/min g/min		cont / int* bar psid		max bar psig	cont / int* Nm lb-in		max KW HP	cont / int* Nm lb-in	
TS 0036	36 2.2	932	34 9	34 9	125 1800	165 2400	190 2750	48 427	67 596	6.6 8.8	44 385	50 440
TS 0045	41 2.5	805	34 9	34 9	125 1800	165 2400	190 2750	64 526	88 731	7.2 9.7	39 341	52 461
TS 0050	49 3.0	678	34 9	34 9	125 1800	165 2400	190 2750	78 693	107 946	7.5 10.1	36 319	70 619
TS 0065	65 4.0	511	34 9	34 9	125 1800	165 2400	190 2750	107 946	145 1284	7.8 10.4	66 582	99 977
TS 0080	82 5.0	409	34 9	34 9	125 1800	165 2400	190 2750	135 1193	184 1624	7.8 10.5	92 816	139 1226
TS 0100	98 6.0	454	45 12	45 12	125 1800	165 2400	190 2750	160 1411	217 1917	10.2 13.8	119 1050	158 1400
TS 0130	130 8.0	430	45 12	57 15	131 1900	131 1900	190 2750	226 2000	226 2000	10.1 13.6	172 1520	172 1520
TS 0165	163 10.0	343	45 12	57 15	103 1500	103 1500	190 2750	226 2000	226 2000	8.1 10.9	165 1460	165 1460
TS 0195	195 11.9	287	45 12	57 15	83 1200	83 1200	190 2750	226 2000	226 2000	6.8 9.1	179 1586	179 1586
TS 0230	228 13.9	246	45 12	57 15	76 1100	76 1100	190 2750	226 2000	226 2000	5.8 7.8	190 1680	190 1680
TS 0260	260 15.9	216	45 12	57 15	69 1000	69 1000	190 2750	226 2000	226 2000	5.1 6.9	188 1660	188 1660
TS 0295	293 17.9	191	45 12	57 15	62 900	62 900	190 2750	226 2000	226 2000	4.6 6.1	181 1600	181 1600
TS 0330	328 20.0	171	45 12	57 15	41 600	41 600	190 2750	226 2000	226 2000	4.0 5.4	181 1600	181 1600
TS 0365	370 22.6	151	45 12	57 15	41 600	41 600	190 2750	226 2000	226 2000	3.6 4.8	191 1690	191 1690
TS 0390	392 24.0	143	45 12	57 15	41 600	41 600	190 2750	226 2000	226 2000	3.4 4.5	179 1580	179 1580

Performance data based on testing using 10W40 oil with a viscosity of 43,1 cSt. (200 SUS) at 54° C (130° F). Performance data is typical. Actual data may vary slightly from one production motor to another.

Les donnees sur les performances sont basees sur des tests utilisant de l'huile 10W40 d'une viscosite de 200 SUS a 54°C (130°F). Ces donnees correspondent a des situations typiques. Les donnees reelles peuvent varier legerement d'un moteur de production a l'autre.

Leistungsdaten sind gemessen mit SAE 10W40 bei einer Viskosität von 43,1 Cst bei 54°C. Geringfügige Abweichungen von den Katalogdaten sind möglich.

Datos tecnicos obtenidos con aceite 10W40 de 200 SUS de viscosidad a 54°C (130°F). Los datos proporcionados son valores tipicos. Los valores exactos reales podrian tener una pequena variacion entre distintos motores.

* Intermittent operation rating applies to 10% of every minute.
Intermittierende Werte maximal 10% von jeder Betriebsminute.
Fonctionnement interm. 10% max. de chaque minute d'utilisation.
Capacidad de funcionamiento intermitente valida para 10% por cada minuto.

TS 0036

2.2 cu in / rev

PRESSURE (PSID)

	500	1000	1500	1800	2000	2400
.5	109 46	225 37	344 26	419 20	470 15	567 7
1	111 99	230 89	351 78	429 71	478 68	579 58
2	112 203	236 192	363 179	442 172	493 170	598 159
3	112 307	241 296	369 283	449 276	503 270	609 259
4	108 413	241 398	372 383	452 376	508 371	619 360
5	104 517	238 502	370 487	454 478	507 473	621 460
7	88 725	225 710	360 694	444 681	500 674	615 661
9	71 933	207 916	344 896	425 885	483 876	599 862
12	48 1245	184 1225	321 1203	405 1192	459 1181	572 1163

TORQUE (LB IN) 599
SPEED (RPM) 862

Flow (GPM)

36 cc / rev

EU

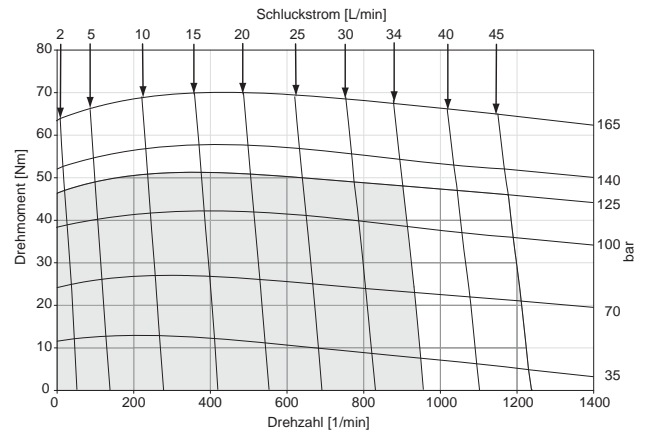

TS 0045

2.5 cu in / rev

PRESSURE (PSID)

	500	1000	1500	1800	2000	2400
.5	119 32	263 18	413 3			
1	123 77	277 61	425 44	518 37	581 28	705 18
2	132 168	290 150	450 131	542 122	606 113	719 97
3	136 256	296 239	462 220	557 211	623 199	748 184
4	132 344	296 326	464 307	567 296	635 286	768 269
5	129 433	290 416	464 394	567 381	639 371	779 352
7	119 610	284 590	460 567	565 551	635 541	779 521
9	109 785	277 765	450 740	555 723	625 710	768 690

TORQUE (LB IN) 779
SPEED (RPM) 521

Flow (GPM)

41 cc / rev

EU

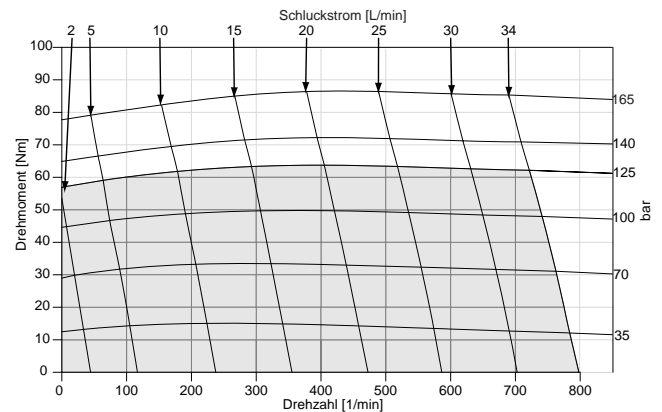

Cont.

Int.

Intermittent operation rating applies to 10% of every minute.
Fonctionnement interm. 10% max. de chaque minute d'utilisation.

Intermittierende Werte maximal 10% von jeder Betriebsminute.
Capacidad de funcionamiento intermitente valida para 10% por cada minuto.

Performance data based on testing using 10W40 oil with a viscosity of 200 SUS at 54° C (130° F). Performance data is typical. Actual data may vary slightly from one production motor to another.

Leistungsdaten sind gemessen mit SAE 10W40 bei einer Viskosität von 43,1 Cst bei 54°C. Geringfügige Abweichungen von den Katalogdaten sind möglich.

Les données sur les performances sont basées sur des tests utilisant de l'huile 10W40 d'une viscosité de 200 SUS à 54°C (130°F). Ces données correspondent à des situations typiques. Les données réelles peuvent varier légèrement d'un moteur de production à l'autre.

Datos tecnicos obtenidos con aceite 10W40 de 200 SUS de viscosidad a 54°C (130°F). Los datos proporcionados son valores típicos. Los valores exactos reales podrían tener una pequeña variación entre distintos motores.

TS 0050

3.0 cu in / rev

PRESSURE (PSID)

	500	1000	1500	1800	2000	2400
.5	146 25	324 13	506 0			
1	156 66	338 50	521 35	631 28	701 20	842 9
2	166 141	359 127	555 110	666 102	742 94	877 80
3	162 218	365 203	566 186	688 176	764 168	912 153
4	164 295	361 279	570 261	693 251	775 242	936 227
5	156 372	359 355	568 337	691 327	779 317	947 302
7	146 525	350 506	561 486	691 474	775 466	949 448
9	135 678	338 659	551 638	680 623	766 615	939 596

Flow (GPM)

TORQUE (LB IN) 939
SPEED (RPM) 596

49 cc / rev

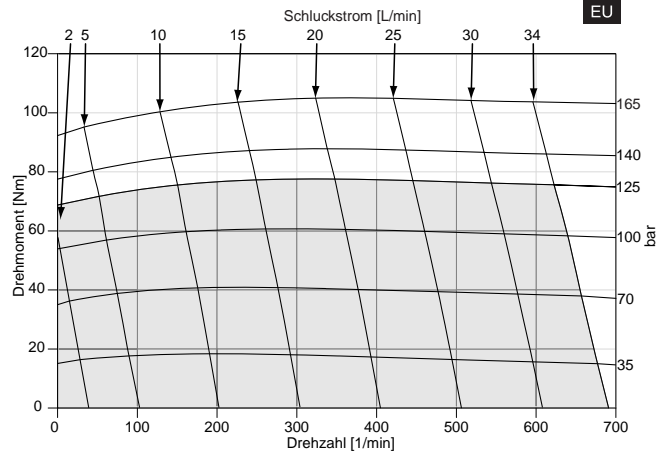

TS 0065

4.0 cu in / rev

PRESSURE (PSID)

	500	1000	1500	1800	2000	2400
.5	217 22	459 14	707 6	862 1		
1	225 51	479 42	735 34	887 29	992 24	1194 17
2	237 108	496 98	761 90	921 85	1028 81	1225 70
3	237 166	504 156	777 147	941 140	1045 136	1251 126
4	228 224	501 214	777 203	946 197	1054 192	1273 181
5	225 281	496 271	775 260	946 252	1059 247	1282 237
7	208 396	485 385	763 373	938 364	1051 359	1282 347
9	194 511	468 499	749 485	924 476	1037 470	1265 457

Flow (GPM)

TORQUE (LB IN) 1282
SPEED (RPM) 347

65 cc / rev

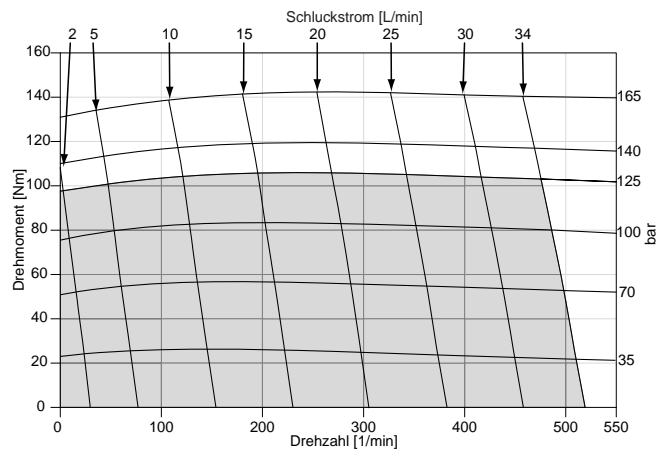

Intermittent operation rating applies to 10% of every minute.
Fonctionnement interm. 10% max. de chaque minute d'utilisation.

Performance data based on testing using 10W40 oil with a viscosity of 200 SUS at 54° C (130° F). Performance data is typical. Actual data may vary slightly from one production motor to another.

Les données sur les performances sont basées sur des tests utilisant de l'huile 10W40 d'une viscosité de 200 SUS à 54°C (130°F). Ces données correspondent à des situations typiques. Les données réelles peuvent varier légèrement d'un moteur de production à l'autre.

Cont. Int.
Intermittierende Werte maximal 10% von jeder Betriebsminute.
Capacidad de funcionamiento intermitente valida para 10% por cada minuto.

Leistungsdaten sind gemessen mit SAE 10W40 bei einer Viskosität von 43,1 Cst bei 54°C. Geringfügige Abweichungen von den Katalogdaten sind möglich.

Datos tecnicos obtenidos con aceite 10W40 de 200 SUS de viscosidad a 54°C (130°F). Los datos proporcionados son valores tipicos. Los valores exactos reales podrian tener una pequena variacion entre distintos motores.

TS 0080

5.0 cu in / rev

PRESSURE (PSID)

	500	1000	1500	1800	2000	2400
.5	259 18	563 10	881 5	1078 1		
1	274 40	589 33	911 26	1100 22	1230 19	1489 11
2	285 86	615 78	952 70	1144 67	1281 63	1530 53
3	293 132	630 124	970 116	1174 110	1311 106	1570 98
4	285 179	630 171	978 161	1185 155	1330 152	1604 142
5	285 226	626 216	978 206	1196 200	1341 196	1626 185
7	267 317	622 307	974 296	1189 290	1337 285	1626 275
9	256 410	604 398	959 387	1178 379	1322 375	1611 362

Flow (GPM)

TORQUE (LB IN) 1611
SPEED (RPM) 362

82 cc / rev

EU

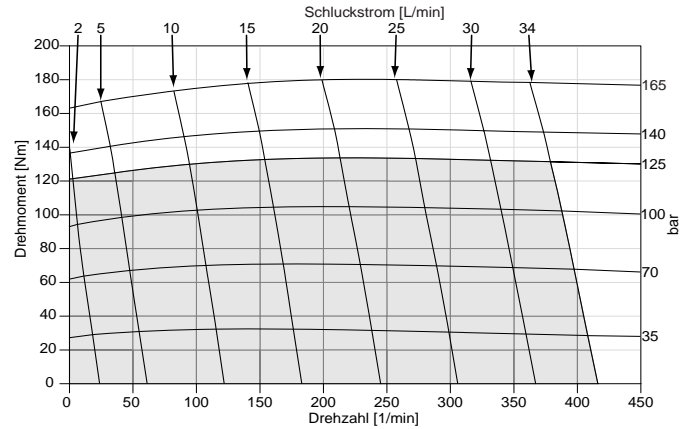

TS 0100

6.0 cu in / rev

PRESSURE (PSID)

	500	1000	1500	1800	2000	2400
.5	316 16	674 13	1045 9	1267 7	1411 4	1708 0
1	327 34	698 32	1072 27	1298 25	1454 23	1743 18
2	339 74	725 69	1111 64	1353 61	1509 58	1805 53
3	351 111	741 107	1146 102	1388 98	1544 95	1852 89
4	351 148	752 143	1162 139	1404 135	1571 132	1887 126
5	347 187	749 183	1170 176	1415 172	1583 169	1910 162
7	320 264	737 257	1162 250	1415 246	1587 242	1926 235
9	308 339	721 333	1142 325	1400 319	1571 316	1910 307
12	257 454	674 446	1096 437	1474 430	1524 426	1864 418

Flow (GPM)

TORQUE (LB IN) 1910
SPEED (RPM) 307

98 cc / rev

EU

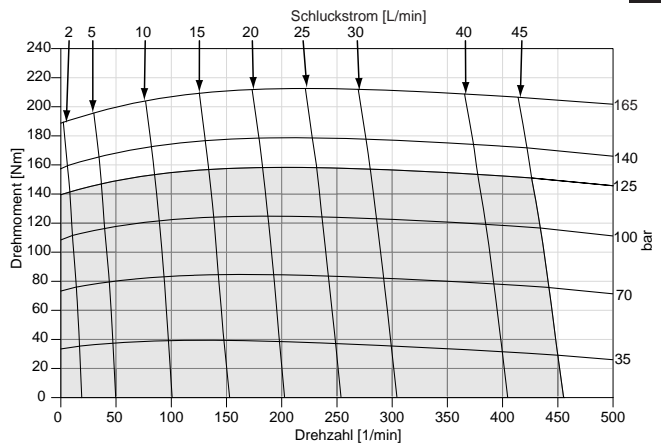

Intermittent operation rating applies to 10% of every minute.
Fonctionnement interm. 10% max. de chaque minute d'utilisation.

Performance data based on testing using 10W40 oil with a viscosity of 200 SUS at 54° C (130° F). Performance data is typical. Actual data may vary slightly from one production motor to another.

Les données sur les performances sont basées sur des tests utilisant de l'huile 10W40 d'une viscosité de 200 SUS à 54°C (130°F). Ces données correspondent à des situations typiques. Les données réelles peuvent varier légèrement d'un moteur de production à l'autre.

Intermittierende Werte maximal 10% von jeder Betriebsminute.

Capacidad de funcionamiento intermitente valida para 10% por cada minuto.

Leistungsdaten sind gemessen mit SAE 10W40 bei einer Viskosität von 43,1 Cst bei 54°C. Geringfügige Abweichungen von den Katalogdaten sind möglich.

Datos tecnicos obtenidos con aceite 10W40 de 200 SUS de viscosidad a 54°C (130°F). Los datos proporcionados son valores típicos. Los valores exactos reales podrían tener una pequeña variación entre distintos motores.

Cont.

Int.

TS 0130

8.0 cu in / rev PRESSURE (PSID)

	500	1000	1500	1800	1900
.5	455 11	966 10	1485 7	1802 5	1897 4
1	463 27	983 24	1511 21	1836 19	1931 18
2	476 55	1018 52	1563 49	1893 46	1988 45
3	485 84	1039 81	1594 77	1927 73	2027 73
4	489 113	1048 109	1611 105	1944 103	2044 101
5	481 142	1044 138	1615 133	1953 130	2057 129
7	459 199	1026 195	1598 190	1944 186	2044 185
9	411 257	983 252	1568 246	1914 242	2022 241
12	342 343	914 338	1494 331	1874 327	1953 325
15	260 430	823 424	1394 416	1745 411	1849 410

130 cc / rev

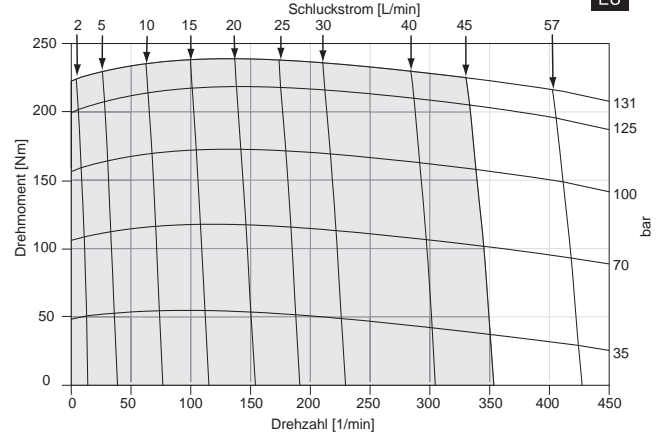

Flow (GPM)

TS 0165

10.0 cu in / rev PRESSURE (PSID)

	250	500	1000	1250	1500
.5	227 12	537 9	1148 7	1461 6	1772 4
1	237 23	554 21	1177 18	1496 16	1813 15
2	247 46	578 44	1226 40	1560 38	1891 37
3	254 69	591 67	1263 63	1600 61	1936 59
4	251 91	595 89	1276 86	1621 84	1965 82
5	239 115	587 113	1288 109	1634 107	1981 104
7	204 162	562 159	1267 154	1627 151	1985 149
9	155 208	517 205	1230 200	1594 197	1956 194
12	61 277	427 274	1140 268	1509 265	1874 261
15		324 343	1029 337	1394 334	1755 331

163 cc / rev

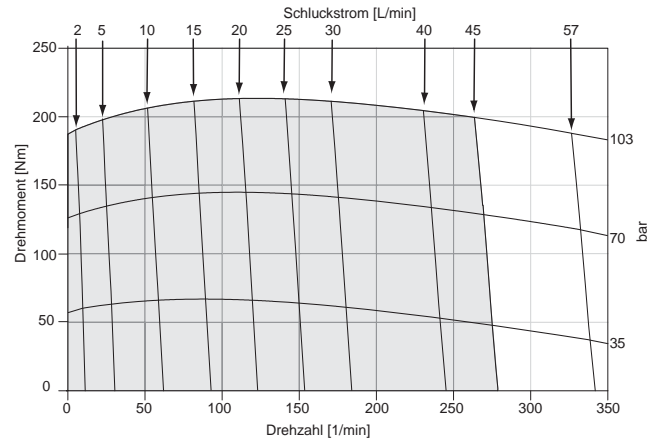

Flow (GPM)

Intermittent operation rating applies to 10% of every minute.
Fonctionnement interm. 10% max. de chaque minute d'utilisation.

Cont. Int.
Intermittierende Werte maximal 10% von jeder Betriebsminute.
Capacidad de funcionamiento intermitente valida para 10% por cada minuto.

Performance data based on testing using 10W40 oil with a viscosity of 200 SUS at 54° C (130° F). Performance data is typical. Actual data may vary slightly from one production motor to another.

Leistungsdaten sind gemessen mit SAE 10W40 bei einer Viskosität von 43,1 Cst bei 54°C. Geringfügige Abweichungen von den Katalogdaten sind möglich.

Les données sur les performances sont basées sur des tests utilisant de l'huile 10W40 d'une viscosité de 200 SUS à 54°C (130°F). Ces données correspondent à des situations typiques. Les données réelles peuvent varier légèrement d'un moteur de production à l'autre.

Datos tecnicos obtenidos con aceite 10W40 de 200 SUS de viscosidad a 54°C (130°F). Los datos proporcionados son valores tipicos. Los valores exactos reales podrian tener una pequena variacion entre distintos motores.

TS 0195

11.9 cu in / rev

	PRESSURE (PSID)				
	250	500	750	1000	1200
.5	318 9.4	701 8.9	1095 8.5	1504 7.7	1780 6.8
1	336 19	720 18	1119 17	1535 17	1807 17
2	351 38	744 38	1152 37	1579 36	1854 36
3	363 58	760 57	1172 56	1602 55	1882 54
4	355 76	756 76	1173 75	1610 74	1890 73
5	341 95	744 95	1166 94	1610 93	1886 92
7	300 135	705 134	1128 132	1575 131	1850 130
9	241 173	646 172	1069 170	1516 169	1791 168
12	142 232	543 230	961 229	1398 227	1677 226
15	9 288	409 287	824 286	1256 284	1539 283

Flow (GPM)

195 cc / rev

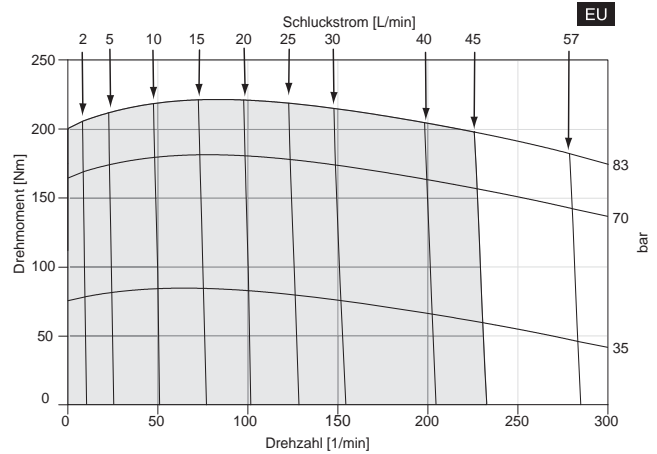

TORQUE (LB IN) 1677
SPEED (RPM) 226

TS 0230

13.9 cu in / rev

	PRESSURE (PSID)				
	250	500	750	1000	1100
.5	373 8.3	806 8.2	1248 7.8	1714 7.2	1836 6.9
1	382 16.6	820 16.4	1267 15.8	1733 15.1	1865 14.8
2	409 33	850 32	1298 32	1768 31	1899 31
3	414 49	859 49	1316 48	1802 47	1919 47
4	408 66	854 65	1323 65	1816 64	1938 64
5	383 83	845 82	1318 81	1821 80	1943 79
7	338 113	811 114	1292 113	1797 112	1938 111
9	261 147	747 147	1237 146	1738 145	1899 144
12	111 199	615 199	1120 197	1626 194	1800 193
15	479 246	987 244	1473 241	1650 240	

Flow (GPM)

228 cc / rev

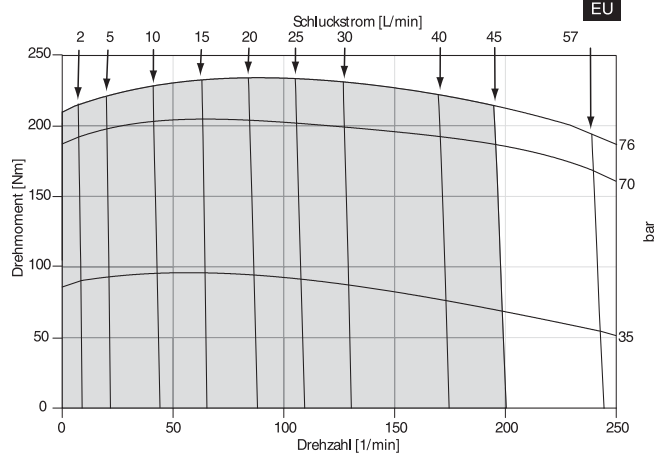

TORQUE (LB IN) 1899
SPEED (RPM) 144

Cont.

Int.

Intermittent operation rating applies to 10% of every minute.
Fonctionnement interm. 10% max. de chaque minute d'utilisation.

Intermittierende Werte maximal 10% von jeder Betriebsminute.
Capacidad de funcionamiento intermitente valida para 10% por cada minuto.

Performance data based on testing using 10W40 oil with a viscosity of 200 SUS at 54° C (130° F). Performance data is typical. Actual data may vary slightly from one production motor to another.

Leistungsdaten sind gemessen mit SAE 10W40 bei einer Viskosität von 43,1 Cst bei 54°C. Geringfügige Abweichungen von den Katalogdaten sind möglich.

Les données sur les performances sont basées sur des tests utilisant de l'huile 10W40 d'une viscosité de 200 SUS à 54°C (130°F). Ces données correspondent à des situations typiques. Les données réelles peuvent varier légèrement d'un moteur de production à l'autre.

Datos tecnicos obtenidos con aceite 10W40 de 200 SUS de viscosidad a 54°C (130°F). Los datos proporcionados son valores tipicos. Los valores exactos reales podrian tener una pequena variacion entre distintos motores.

TS 0260

15.9 cu in / rev

PRESSURE (PSID)

	250	500	750	1000
.5	399 7.2	915 6.9	1431 6.4	1948 6.0
1	412 14.5	936 14.0	1460 13.6	1984 13.1
2	419 29.0	956 28.3	1493 27.6	2030 26.8
3	427 43	971 43	1516 42	2060 41
4	412 58	966 57	1521 57	2076 56
5	401 71	961 71	1521 71	2081 70
7	348 101	915 100	1483 100	2050 99
9	271 130	844 129	1416 128	1989 128
12	133 174	706 173	1278 172	1851 171
15		547 216	1117 215	1687 214

Flow (GPM)

260 cc / rev

EU

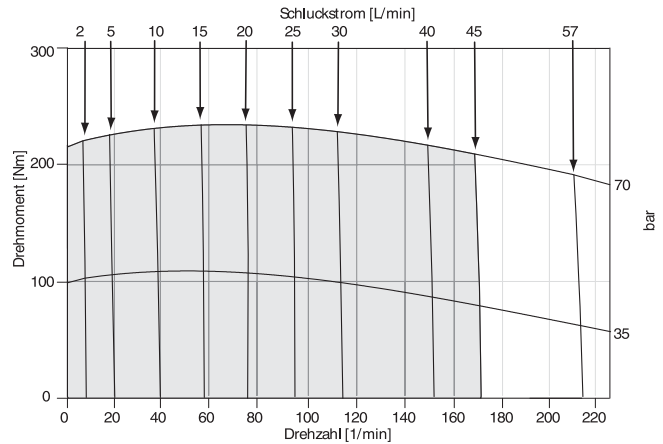

TORQUE (LB IN) 1851
SPEED (RPM) 171

TS 0295

17.9 cu in / rev

PRESSURE (PSID)

	250	500	750	900
.5	384 6.4	1048 6.0	1713 5.3	2111 4.9
1	394 12.6	1068 12.2	1742 11.7	2146 11.4
2	397 25.6	1093 25.1	1788 24.6	2205 24.3
3	406 39	1107 38	1809 37	2229 36
4	397 50	1107 50	1818 49	2244 49
5	365 64	1088 63	1810 62	2244 61
7	316 90	1038 89	1761 88	2195 87
9	223 115	955 114	1687 113	2126 112
12	60 154	792 153	1524 151	1964 150
15		605 191	1325 189	1757 188

Flow (GPM)

293 cc / rev

EU

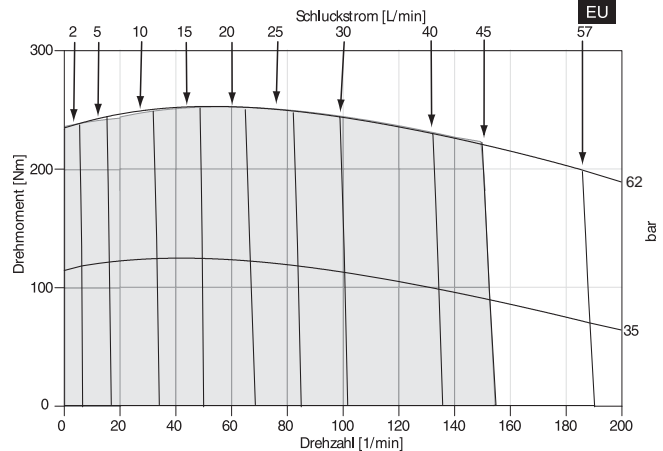

TORQUE (LB IN) 2126
SPEED (RPM) 112

Intermittent operation rating applies to 10% of every minute.
Fonctionnement interm. 10% max. de chaque minute d'utilisation.

Performance data based on testing using 10W40 oil with a viscosity of 200 SUS at 54° C (130° F). Performance data is typical. Actual data may vary slightly from one production motor to another.

Les donnees sur les performances sont basees sur des tests utilisant de l'huile 10W40 d'une viscosite de 200 SUS a 54°C (130°F). Ces donnees correspondent a des situations typiques. Les donnees reelles peuvent varier legerement d'un moteur de production a l'autre.

Intermittierende Werte maximal 10% von jeder Betriebsminute.

Capacidad de funcionamiento intermitente valida para 10% por cada minuto.

Leistungsdaten sind gemessen mit SAE 10W40 bei einer Viskosität von 43,1 Cst bei 54°C. Geringfügige Abweichungen von den Katalogdaten sind möglich.

Datos tecnicos obtenidos con aceite 10W40 de 200 SUS de viscosidad a 54°C (130°F). Los datos proporcionados son valores tipicos. Los valores exactos reales podrian tener una pequena variacion entre distintos motores.

Cont.

Int.

TS 0330

20.0 cu in / rev

PRESSURE (PSID)

	250	500	600
.5	481 5.7	1201 5.1	1489 4.6
1	469 11.4	1229 11.1	1533 10.6
2	416 22.8	1258 22.5	1594 21.7
3	377 35	1270 34	1627 33
4	323 46	1266 45	1643 44
5	252 57	1245 56	1643 56
7	154 80	1189 79	1602 78
9	55 103	1099 102	1517 102
12		913 137	1331 136
15		706 171	1087 170

TORQUE (LB IN) 1517
SPEED (RPM) 102

Flow (GPM)

328 cc / rev

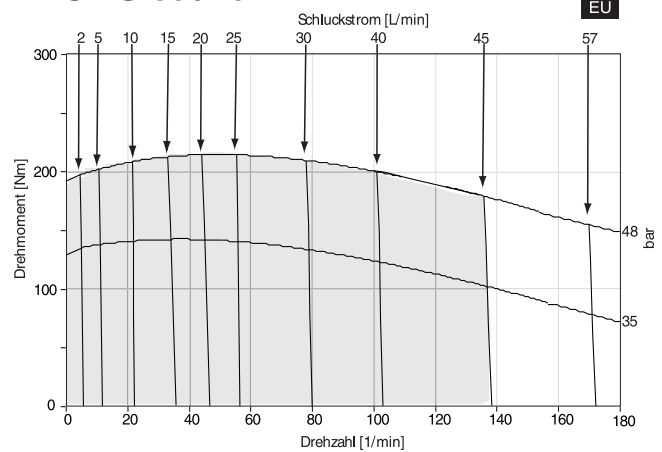

TS 0365

22.6 cu in / rev

PRESSURE (PSID)

	250	500	600
.5	680 5.1	1405 4.9	1650 4.6
1	688 10.2	1438 9.8	1703 9.7
2	686 20.4	1479 19.8	1756 19.6
3	692 30.3	1495 30.2	1784 30.0
4	720 40.2	1487 39.9	1796 39.8
5	703 50.6	1466 50.0	1772 49.8
7	572 70.6	1373 70.1	1695 69.9
9	440 91.4	1251 90.3	1572 89.9
12	189 121.5	1014 120.9	1344 120.7
15		701 151.1	1022 150.9

TORQUE (LB IN) 1695
SPEED (RPM) 69.9

Flow (GPM)

370 cc / rev

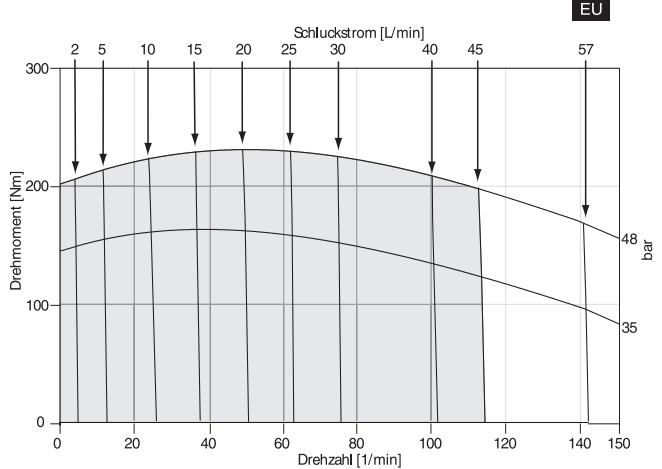

Intermittent operation rating applies to 10% of every minute.
Fonctionnement interm. 10% max. de chaque minute d'utilisation.

Performance data based on testing using 10W40 oil with a viscosity of 200 SUS at 54° C (130° F). Performance data is typical. Actual data may vary slightly from one production motor to another.

Les donnees sur les performances sont basees sur des tests utilisant de l'huile 10W40 d'une viscosite de 200 SUS a 54°C (130°F). Ces donnees correspondent a des situations typiques. Les donnees reelles peuvent varier legerement d'un moteur de production a l'autre.

Intermittierende Werte maximal 10% von jeder Betriebsminute.

Capacidad de funcionamiento intermitente valida para 10% por cada minuto.

Leistungsdaten sind gemessen mit SAE 10W40 bei einer Viskosität von 43,1 Cst bei 54°C. Geringfügige Abweichungen von den Katalogdaten sind möglich.

Datos tecnicos obtenidos con aceite 10W40 de 200 SUS de viscosidad a 54°C (130°F). Los datos proporcionados son valores tipicos. Los valores exactos reales podrian tener una pequena variacion entre distintos motores.

Cont.

Int.

TS 0390

24.0 cu in / rev

	PRESSURE (PSID)		
	250	500	600
.5	604	1324	1492
	4.5	4.0	3.8
1	640	1356	1540
	9.3	9.2	9.0
2	690	1408	1608
	18.6	18.1	17.9
3	700	1440	1664
	28.4	28.1	27.7
4	705	1452	1692
	37.5	37.0	36.8
5	715	1444	1712
	48.1	47.1	46.8
7	642	1392	1692
	67.2	66.2	65.8
9	496	1296	1616
	85.6	85.1	84.9
12	292	1092	1412
	115.9	114.5	113.9
15	62	832	1140
	144.1	143.1	142.7

Flow (GPM)

392 cc / rev

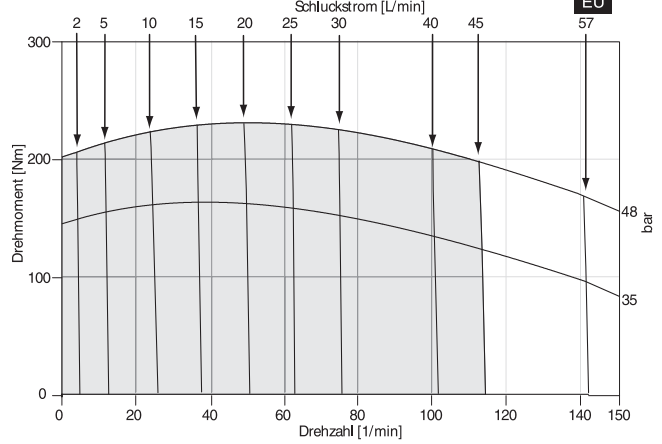

TORQUE (LB IN) 1616
SPEED (RPM) 84.9

Intermittent operation rating applies to 10% of every minute.
Fonctionnement interm. 10% max. de chaque minute d'utilisation.

Performance data based on testing using 10W40 oil with a viscosity of 200 SUS at 54° C (130° F). Performance data is typical. Actual data may vary slightly from one production motor to another.

Les donnees sur les performances sont basees sur des tests utilisant de l'huile 10W40 d'une viscosite de 200 SUS a 54°C (130°F). Ces donnees correspondent a des situations typiques. Les donnees reelles peuvent varier legerement d'un moteur de production a l'autre.

003 TS.indd, js

Cont.

Int.

Intermittierende Werte maximal 10% von jeder Betriebsminute.

Capacidad de funcionamiento intermitente valida para 10% por cada minuto.

Leistungsdaten sind gemessen mit SAE 10W40 bei einer Viskositat von 43,1 Cst bei 54°C. Geringfuegige Abweichungen von den Katalogdaten sind moeglich.

Datos tecnicos obtenidos con aceite 10W40 de 200 SUS de viscosidad a 54°C (130°F). Los datos proporcionados son valores tipicos. Los valores exactos reales podrian tener una pequena variacion entre distintos motores.

A 5/16-24 straight thread o-ring drain port is provided in the flange of the front housing. This port is to be connected to the reservoir. The purpose of this port is to relieve pressure in the polypropylene rear cover in the rare event of a motor section seal leak.

Maximum side load 300# at 1 inch from mounting face.

Shaft torque is limited to 2000 in-lbs since it is made from 316 stainless steel 1" keyed shaft. Other shaft types or shaft taper locks will increase allowable shaft torque.

Code: FS

**4 Bolt,
 7/8"-14 SAE
 O-Ring**

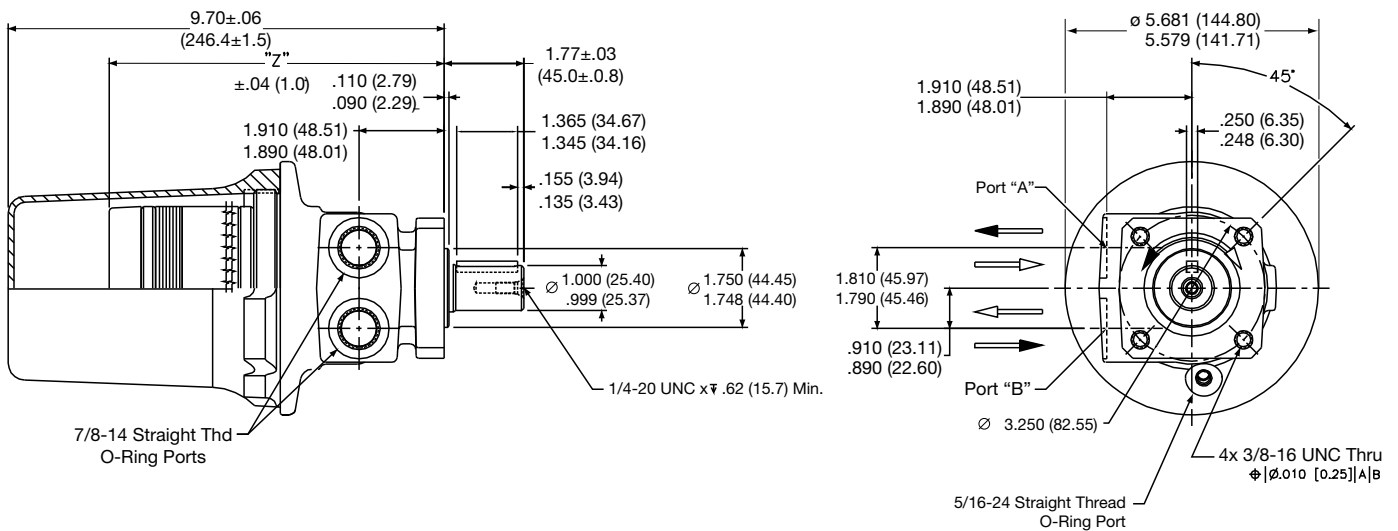

* Do not plug 5/16-24 drain port

Code FS disp.	0036	0045	0050	0065	0080	0100	0130	0165	0195	0230	0260	0295	0330	0365	0390
Weight/Gewicht kg	8.3	8.3	8.4	8.5	8.7	8.8	9.0	9.3	9.8	9.9	10.1	10.3	10.7	11.0	11.1
Poids/Peso (lb)	(18.3)	(18.4)	(18.5)	(18.8)	(19.1)	(19.4)	(19.9)	(20.6)	(21.5)	(21.8)	(22.3)	(22.8)	(23.5)	(24.2)	(24.5)
Length"Z" mm	164.4	165.5	167.0	170.2	173.3	176.5	182.9	189.2	195.6	201.9	208.3	214.6	221.0	229.6	233.7
"Z" (in)	(6.47)	(6.52)	(6.57)	(6.70)	(6.82)	(6.95)	(7.20)	(7.45)	(7.70)	(7.95)	(8.20)	(8.45)	(8.70)	(9.04)	(9.20)

English equivalents for metric specifications are shown in ().

15 Displacements	(2.2 – 24.0 in ³ /rev)	
15 Schluckvolumen	36 . . . 390 cm ³ /rev	
15 Cylindrée		
15 Desplazamientos		
	Cont	Int
Maximum Pressure	(2030 psid)	(2750 psid)
Eingangsdruck	. . .140 bar	. . .190 bar
Chaute de pression max.		
Presion Maxima		
Maximum Oil Flow	(20 gpm)	
Schluckstrom	. . . 75 lpm	
Débit d'huile		
Caudal Maximo de Aceite		
Maximum Speed	(1000 rpm)	
Drehzahl	1000 rpm	
Vitesse de rotation		
Velocidad Maxima		
	Cont	Int
Maximum Torque	(4139 lb in)	(5728 lb in)
Max Drehmoment	467 Nm	648 Nm
Couple Maxi		
Torque Maximo		
Maximum Side Load at Key	(1500 lb)	
Seitenlast	. . . 6650 N	
Charges latérales		
Carga Maxima Lateral		

An Improved Medium Duty Low Speed, High Torque Motor

This medium duty motor has higher pressure ratings than the TB motor, for applications requiring higher torque. Robust roller bearings withstand higher side loads and are suitable for chain and sprocket shaft connections. It uses high pressure shaft seals, robust roller bearings and high flow shaft seal cooling.

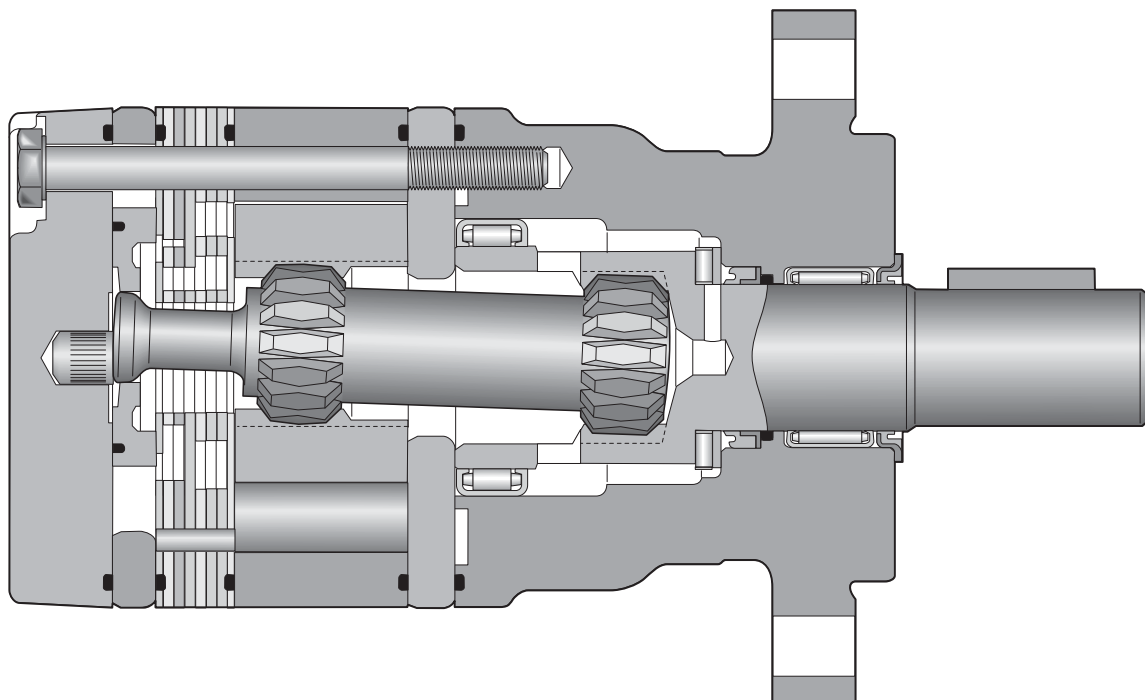

TE

Series





XXXX

Displacement
Schluckvolumen
Cylindrée
Desplazamiento

Code	cm ³ /U cm ³ /tr cm ³ /giro	in ³ /rev
0036	36 / 2.2	
0045	41 / 2.5	
0050	49 / 3.0	
0065	65 / 4.0	
0080	82 / 5.0	
0100	98 / 6.0	
0130	130 / 8.0	
0165	163 / 10.0	
0195	195 / 11.9	
0230	228 / 13.9	
0260	260 / 15.9	
0295	293 / 17.9	
0330	328 / 20.0	
0365	370 / 22.6	
0390	392 / 24.0	

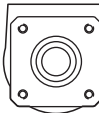

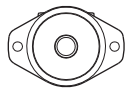
X

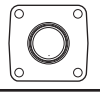
Mounting
Gehäuse
Carter
Montaje

Code	Mounting
A	SAE "A" 2 Bolt, 
F	4 Bolt w/3/8-16 UNC 
M	Magneto 
C	SAE "A" 2 Bolt, Long Pilot 
B	SAE "B" 2 Bolt 
L*	Wheel Mount 
N	Midmount 
U*	Wheel Mount 7/8-14 SAE 

X

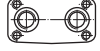
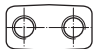
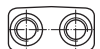
Ports
Anschluß
Plan de raccordement
Lumbreras

Code	Ports
M	5/16-18 UNC Manifold 
P	1/2-14 NPTF 
S	7/8-14 SAE 
W	G 1/2 BSPP 
N	M8 Manifold 

Rear Ports
Endanschluß
Alimentazione Laterale
Orifices arriér

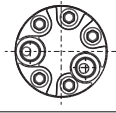
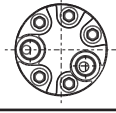











Code	Rear Ports
R	3/4-16 SAE O-ring Axial 
Y	G 1/2 BSPP Axial 

*Not available with port codes M & N

For other available options, see pages 102–103.

XX



Shaft
Welle
Arbre
Eje

Code	Shaft
09	1" Straight w/0.38" Crosshole 
10	1" Keyed, 
11	1" 6B Spline 
12	Short 1" Tapered 
13	Long 1" Keyed 
21	1" Keyed; Corrosion Resistant 
25	1" Tapered 
26	25mm Keyed w/ 8mm Key 
28	7/8" 13 Tooth Spline 
41	Long 6B Spline 
59*	7/8" 13 Tooth Spline SAE 
70	1" Keyed; Stainless Steel 

* Conforms to SAE B recommended length

0

Rotation
Drehrichtung
Direction de rotation
Rotacion

Code	Rotation
0	Standard 
1	Reverse Timed Manifold 

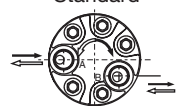
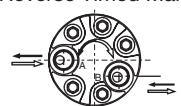
Code	Rear Port Rotation
0	Standard 
1	Reverse Timed Manifold 

Rotation viewed from shaft end.

XXXX

Options
Opciones

Code	Options
AAAA	Black Paint
AAAB	No Paint
AAAC	Double Paint
AAAF	Castle Nut, Black Paint
AABP	Castle Nut, No Paint
AAAG	Fluorocarbon Seals, Black Paint
AAAH	Fluorocarbon Seals, No Paint
AAAJ	High Temperature Commutator Seal, Black Paint
AAFG	High Temperature Commutator Seal, No Paint
AABJ*	Free Running Rotorset, Black Paint
AABK*	Free Running Rotorset, No Paint

*Not applicable to TE0365 or TE0390 displacements

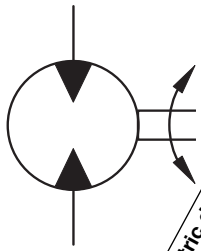

Geometric displacement
Geom. Schluckvolumen
Desplazamientos
Max. speed @ Max. intermittent flow
Max. Drehzahl Intermittierender Betrieb:
Velocidad maxima a caudal intermitente maximo
Max. oil flow
Max. Schluckstrom
Caudal Maximo
Max. Differential Pressure
Max. Druckgefälle
Chute de pression max
Presion diferencial maxima
Max. supply pressure
Max. Eingangsdruck
Presion max entrada
Max. torque
Max. Drehmoment
Couple Maximo
Max. Performance
Max. Leistungsgabe
Maximo rendimiento
Min. starting torque
Min. Anlaufmoment
Couple min. fourni au démarrage
Torque minimo de arranque

Motor Series TE	cm ³ /rev in ³ /rev	Int rev/min	cont / int* l/min g/min		cont / int* bar psid		max bar psig	cont / int* Nm lb-in		max KW HP	cont / int* Nm lb-in	
TE 0036	36 2.2	1141	34 9	42 11	140 2030	190 2750	200 2900	54.6 483	71.1 630	8.5 11.4	44 389	52 460
TE 0045	41 2.5	1024	34 9	42 11	140 2030	190 2750	200 2900	71 624	99 876	10.4 13.9	44 411	64 565
TE 0050	49 3.0	1020	34 9	50 13	140 2030	190 2750	200 2900	90 796	127 1120	12.8 17.2	72 637	98 871
TE 0065	65 4.0	877	45 12	57 15	140 2030	190 2750	200 2900	125 1106	176 1558	14.7 19.8	100 885	137 1211
TE 0080	82 5.0	695	45 12	57 15	140 2030	190 2750	200 2900	160 1416	220 1947	17.3 23.2	128 1133	171 1515
TE 0100	98 6.0	582	45 12	57 15	140 2030	190 2750	200 2900	190 1682	264 2337	17.4 23.4	152 1345	205 1819
TE 0130	130 8.0	438	45 12	57 15	140 2030	190 2750	200 2900	255 2257	352 3116	17.3 23.2	204 1806	274 2423
TE 0165	163 10.0	348	45 12	57 15	140 2030	190 2750	200 2900	310 2744	436 3846	17.0 22.8	248 2195	338 2992
TE 0195	195 11.9	292	45 12	57 15	140 2030	190 2750	200 2900	390 3452	528 4673	17.4 23.4	312 2762	411 3637
TE 0230	228 13.9	328	57 15	75 20	120 1740	165 2400	200 2900	380 3363	514 4554	17.7 23.8	304 2691	411 3637
TE 0260	260 15.9	287	57 15	75 20	110 1595	155 2250	200 2900	400 3540	550 4870	16.7 22.4	320 2832	449 3977
TE 0295	293 17.9	256	57 15	75 20	100 1450	145 2100	200 2900	428 3784	582 5180	15.7 21.0	328 2903	445 3939
TE 0330	328 20.0	228	57 15	75 20	100 1450	135 1950	200 2900	443 3926	600 5312	14.8 19.8	344 3045	453 4014
TE 0365	370 22.6	203	57 15	75 20	95 1378	125 1825	200 2900	467 4133	648 5728	13.6 18.2	373 3301	477 4223
TE 0390	392 24.0	191	57 15	75 20	85 1233	120 1740	200 2900	445 3935	628 5562	12.5 16.8	348 3080	462 4090

Performance data based on testing using 10W40 oil with a viscosity of 43,1 cSt. (200 SUS) at 54° C (130° F). Performance data is typical. Actual data may vary slightly from one production motor to another.

Les donnees sur les performances sont basees sur des tests utilisant de l'huile 10W40 d'une viscosite de 200 SUS a 54°C (130°F). Ces donnees correspondent a des situations typiques. Les donnees reelles peuvent varier legerement d'un moteur de production a l'autre.

Leistungsdaten sind gemessen mit SAE 10W40 bei einer Viskosität von 43,1 Cst bei 54°C. Geringfügige Abweichungen von den Katalogdaten sind möglich.

Datos tecnicos obtenidos con aceite 10W40 de 200 SUS de viscosidad a 54°C (130°F). Los datos proporcionados son valores tipicos. Los valores exactos reales podrian tener una pequena variacion entre distintos motores.

* Intermittent operation rating applies to 10% of every minute.
Intermittierende Werte maximal 10% von jeder Betriebsminute.
Fonctionnement interm. 10% max. de chaque minute d'utilisation.
Capacidad de funcionamiento intermitente valida para 10% por cada minuto.

TE 0036 **2.2 cu in / rev** PRESSURE (PSID)

	500	1000	1500	2000	2750
.5	111 44	225 37	346 25	470 15	
1	113 96	231 86	353 77	480 67	670 40
2	115 202	239 190	365 179	495 169	691 140
3	113 307	241 296	371 282	505 269	709 240
4	109 411	241 397	373 384	509 371	722 340
5	103 516	237 501	371 486	509 470	726 440
7	87 724	225 709	361 691	501 674	711 641
9	72 933	208 916	344 897	482 877	672 841
11	54 1142	190 1117	326 1096	462 1075	629 1045

36 cc / rev

EU

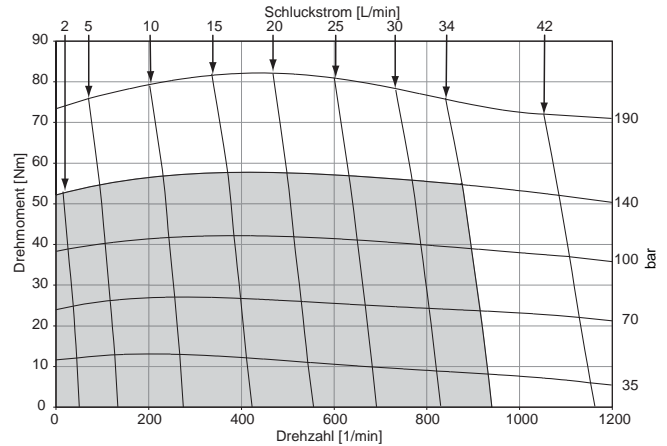

TORQUE (LB IN) 711
SPEED (RPM) 641

Flow (GPM)

TE 0045 **2.5 cu in / rev** PRESSURE (PSID)

	500	1000	1500	2000	2750
.5	121 41	272 35	425 28	579 22	808 10
1	126 86	282 79	440 72	599 65	832 50
2	128 176	288 168	452 161	619 152	867 134
3	126 266	287 257	453 249	620 239	868 221
4	123 356	285 346	454 337	624 326	876 306
5	119 446	281 435	451 425	624 413	877 391
7	105 625	270 613	440 601	615 587	872 562
9	94 805	259 791	430 777	605 761	862 733
11	81 983	246 967	415 950	590 930	849 896

41 cc / rev

EU

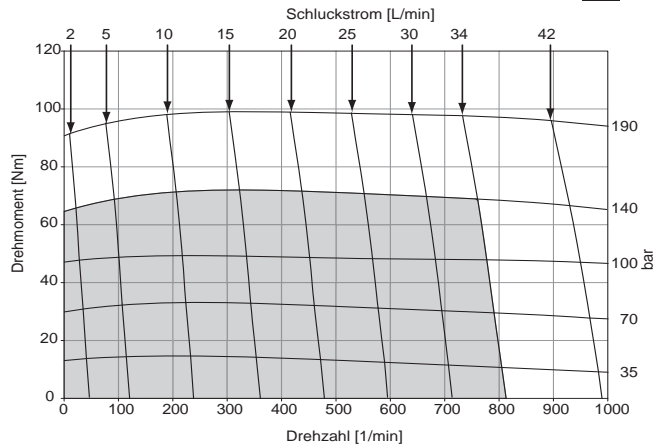

TORQUE (LB IN) 872
SPEED (RPM) 562

Flow (GPM)

Cont.

Int.

Intermittent operation rating applies to 10% of every minute.

Fonctionnement interm. 10% max. de chaque minute d'utilisation.

Performance data based on testing using 10W40 oil with a viscosity of 200 SUS at 54°C (130°F). Performance data is typical. Actual data may vary slightly from one production motor to another.

Les données sur les performances sont basées sur des tests utilisant de l'huile 10W40 d'une viscosité de 200 SUS à 54°C (130°F). Ces données correspondent à des situations typiques. Les données réelles peuvent varier légèrement d'un moteur de production à l'autre.

Intermittierende Werte maximal 10% von jeder Betriebsminute.

Capacidad de funcionamiento intermitente valida para 6 segundos por cada minuto.

Leistungsdaten sind gemessen mit SAE 10W40 bei einer Viskosität von 43,1 Cst bei 54°C. Geringfügige Abweichungen von den Katalogdaten sind möglich.

Datos tecnicos obtenidos con aceite 10W40 de 200 SUS de viscosidad a 54°C (130°F). Los datos proporcionados son valores tipicos. Los valores exactos reales podrian tener una pequena variacion entre distintos motores.

TE 0050 **3.0 cu in / rev** PRESSURE (PSID)

	500	1000	1500	2000	2750
.5	146 32	327 23	513 13	705 6	
1	159 69	345 60	537 50	727 41	1005 17
2	170 145	364 136	563 124	764 113	1057 85
3	167 225	363 214	565 203	768 191	1066 163
4	169 294	367 282	574 271	784 260	1092 231
5	165 363	365 349	574 339	785 327	1097 297
7	156 501	357 485	568 474	782 460	1096 430
9	141 640	342 621	555 609	771 594	1087 561
13	88 904	295 881	503 869	722 851	1036 819

Flow (GPM)

TORQUE (LB IN) 1096
SPEED (RPM) 430

49 cc / rev

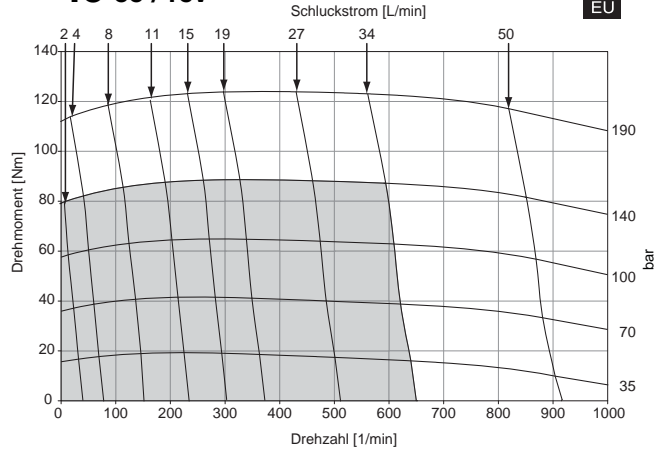

EU

TE 0065 **4.0 cu in / rev** PRESSURE (PSID)

	500	1000	1500	2000	2750
.5	220 24	481 17	743 11	1004 3	
1	232 52	498 45	763 38	1025 31	1411 19
2	239 109	512 102	789 94	1066 85	1469 65
3	238 167	512 159	790 151	1068 141	1474 120
4	237 224	514 215	795 207	1078 197	1492 179
5	233 279	511 271	794 262	1080 252	1502 234
7	216 386	497 376	783 366	1072 356	1497 336
9	195 494	477 483	764 472	1054 460	1481 439
12	152 654	435 641	724 629	1017 617	1445 596
15	102 802	388 789	676 776	969 763	1391 740

Flow (GPM)

TORQUE (LB IN) 1497
SPEED (RPM) 336

65 cc / rev

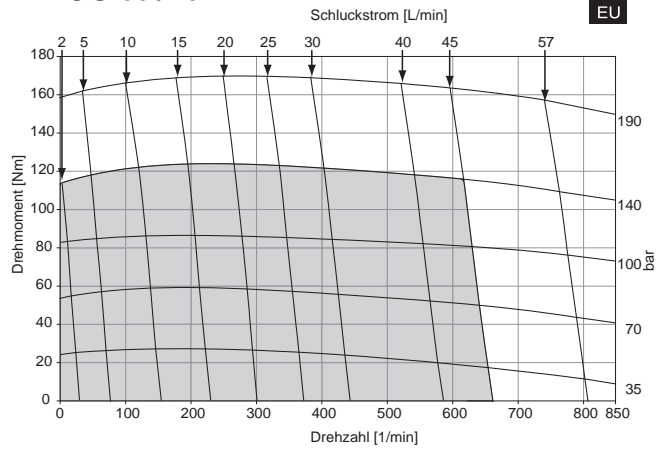

EU

■ Cont.

□ Int.

Intermittent operation rating applies to 10% of every minute.

Fonctionnement interm. 10% max. de chaque minute d'utilisation.

Performance data based on testing using 10W40 oil with a viscosity of 200 SUS at 54° C (130° F). Performance data is typical. Actual data may vary slightly from one production motor to another.

Les données sur les performances sont basées sur des tests utilisant de l'huile 10W40 d'une viscosité de 200 SUS à 54°C (130°F). Ces données correspondent à des situations typiques. Les données réelles peuvent varier légèrement d'un moteur de production à l'autre.

Intermittierende Werte maximal 10% von jeder Betriebsminute.

Capacidad de funcionamiento intermitente valida para 6 segundos por cada minuto.

Leistungsdaten sind gemessen mit SAE 10W40 bei einer Viskosität von 43,1 Cst bei 54°C. Geringfügige Abweichungen von den Katalogdaten sind möglich.

Datos tecnicos obtenidos con aceite 10W40 de 200 SUS de viscosidad a 54°C (130°F). Los datos proporcionados son valores tipicos. Los valores exactos reales podrian tener una pequena variacion entre distintos motores.

TE 0080 **5.0 cu in / rev** PRESSURE (PSID)

	500	1000	1500	2000	2750
.5	261 17	575 8			
1	276 39	596 30	918 23	1245 13	
2	290 85	631 76	974 68	1310 56	1784 35
3	291 131	633 122	978 113	1319 101	1819 79
4	293 177	642 167	995 158	1347 146	1854 121
5	290 223	641 213	999 203	1359 191	1884 165
7	273 316	628 304	989 293	1353 280	1890 253
9	249 408	603 396	966 384	1334 370	1873 340
12	197 546	551 533	916 504	1287 504	1827 472
15	136 686	494 670	857 655	1226 638	1762 603

TORQUE (LB IN) 1890
SPEED (RPM) 253

Flow (GPM)

TE 0100 **6.0 cu in / rev** PRESSURE (PSID)

	500	1000	1500	2000	2750
.5	315 14	687 7			
1	332 33	710 26	1083 18	1460 9	
2	348 71	751 64	1152 55	1541 45	2089 27
3	350 109	756 102	1160 92	1556 83	2138 62
4	353 147	768 140	1185 130	1596 120	2189 99
5	349 186	771 178	1197 168	1622 158	2235 137
7	330 263	759 254	1191 244	1624 232	2258 209
9	302 340	731 330	1167 319	1606 307	2246 284
12	243 456	671 444	1111 433	1555 420	2198 394
15	176 572	606 558	1042 546	1484 533	2121 505

TORQUE (LB IN) 2258
SPEED (RPM) 209

Flow (GPM)

82 cc / rev

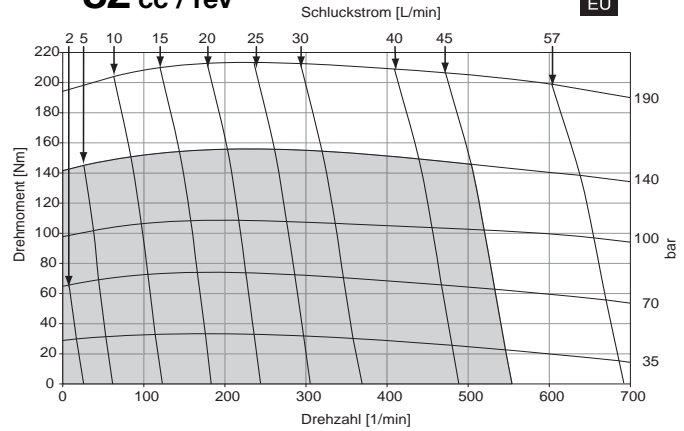

98 cc / rev

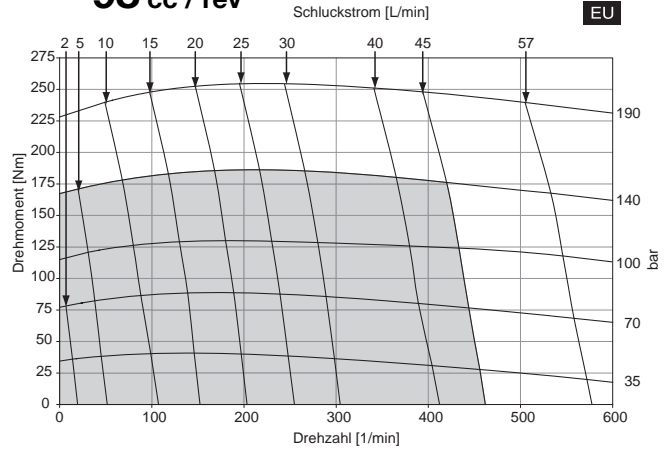

Intermittent operation rating applies to 10% of every minute.

Fonctionnement interm. 10% max. de chaque minute d'utilisation.

Performance data based on testing using 10W40 oil with a viscosity of 200 SUS at 54° C (130° F). Performance data is typical. Actual data may vary slightly from one production motor to another.

Les donnees sur les performances sont basees sur des tests utilisant de l'huile 10W40 d'une viscosite de 200 SUS a 54°C (130°F). Ces donnees correspondent a des situations typiques. Les donnees reelles peuvent varier legerement d'un moteur de production a l'autre.

Intermittierende Werte maximal 10% von jeder Betriebsminute.

Capacidad de funcionamiento intermitente valida para 6 segundos por cada minuto.

Leistungsdaten sind gemessen mit SAE 10W40 bei einer Viskositäet von 43,1 Cst bei 54°C. Geringfügige Abweichungen von den Katalogdaten sind moeglich.

Datos tecnicos obtenidos con aceite 10W40 de viscosidad a 54°C (130°F). Los datos proporcionados son valores tipicos. Los valores exactos reales podrian tener una pequena variacion entre distintos motores.

Cont.

Int.

TE 0130 **8.0 cu in / rev** PRESSURE (PSID)

	500	1000	1500	2000	2750
.5	445 12	962 10	1488 7	2018 3	
1	464 27	996 24	1525 21	2051 17	2835 5
2	482 55	1032 53	1584 49	2136 44	2940 31
3	483 84	1037 81	1594 77	2150 72	2961 60
4	483 113	1051 110	1619 105	2184 100	3015 87
5	478 142	1050 138	1625 133	2201 128	3050 114
7	450 200	1029 195	1613 190	2195 183	3054 169
9	414 257	993 252	1579 247	2166 239	3030 224
12	338 344	915 338	1503 331	2096 323	2961 306
15	252 431	827 424	1408 416	1996 407	2851 389

TORQUE (LB IN) 3054
SPEED (RPM) 169

Flow (GPM)

130 cc / rev Schlickstrom [L/min] **EU**

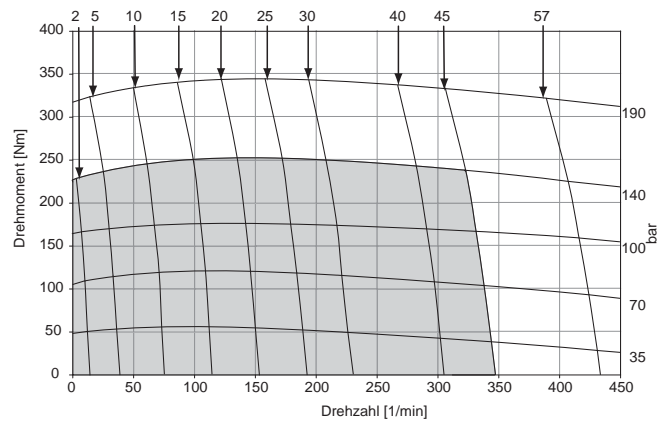

TE 0165 **10.0 cu in / rev** PRESSURE (PSID)

	500	1000	1500	2000	2750
.5	552 9	1175 7	1813 4	2457 3	
1	574 21	1213 18	1856 16	2499 12	3465 7
2	597 44	1263 41	1938 38	2614 33	3604 25
3	600 67	1273 64	1955 60	2634 55	3628 46
4	603 90	1299 87	1997 83	2691 78	3705 67
5	597 113	1302 109	2015 105	2727 100	3767 89
7	569 159	1286 155	2009 150	2732 144	3791 133
9	523 205	1244 201	1976 195	2707 189	3773 177
12	429 274	1152 269	1890 263	2630 256	3701 242
15	316 344	1039 338	1769 331	2500 323	3568 308

TORQUE (LB IN) 3791
SPEED (RPM) 133

Flow (GPM)

163 cc / rev Schlickstrom [L/min] **EU**

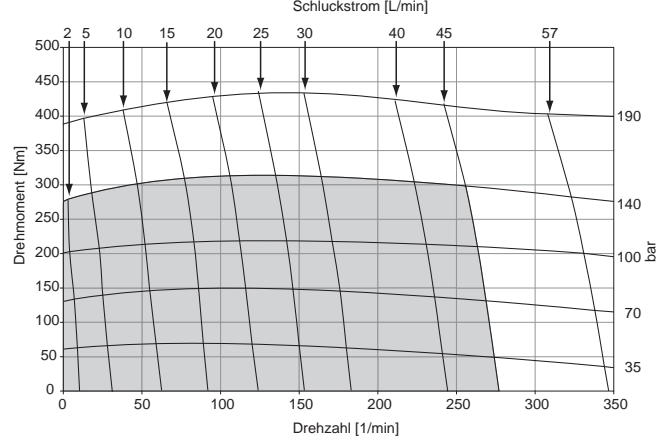

Cont. Int.

Intermittent operation rating applies to 10% of every minute.

Fonctionnement interm. 10% max. de chaque minute d'utilisation.

Performance data based on testing using 10W40 oil with a viscosity of 200 SUS at 54° C (130° F). Performance data is typical. Actual data may vary slightly from one production motor to another.

Les données sur les performances sont basées sur des tests utilisant de l'huile 10W40 d'une viscosité de 200 SUS à 54°C (130°F). Ces données correspondent à des situations typiques. Les données réelles peuvent varier légèrement d'un moteur de production à l'autre.

Intermittierende Werte maximal 10% von jeder Betriebsminute.

Capacidad de funcionamiento intermitente valida para 6 segundos por cada minuto.

Leistungsdaten sind gemessen mit SAE 10W40 bei einer Viskosität von 43,1 Cst bei 54°C. Geringfügige Abweichungen von den Katalogdaten sind möglich.

Datos tecnicos obtenidos con aceite 10W40 de viscosidad a 54°C (130°F). Los datos proporcionados son valores tipicos. Los valores exactos reales podrian tener una pequena variacion entre distintos motores.

TE 0195 **11.9 cu in / rev** PRESSURE (PSID)

	500	1000	1500	2000	2750
.5	710 8	1519 7	2344 5	3182 3	
1	736 18	1558 16	2387 14	3221 12	4457 6
2	758 37	1596 35	2445 33	3302 30	4558 22
3	758 56	1604 54	2459 51	3315 48	4576 39
4	757 75	1618 73	2482 70	3346 67	4619 56
5	747 95	1615 92	2488 89	3360 85	4643 74
7	705 133	1586 130	2467 127	3343 122	4631 111
9	646 172	1528 169	2415 165	3300 160	4590 147
12	530 230	1408 226	2303 221	3197 215	4494 201
15	394 288	1273 283	2147 278	3027 272	4308 256

195 cc / rev

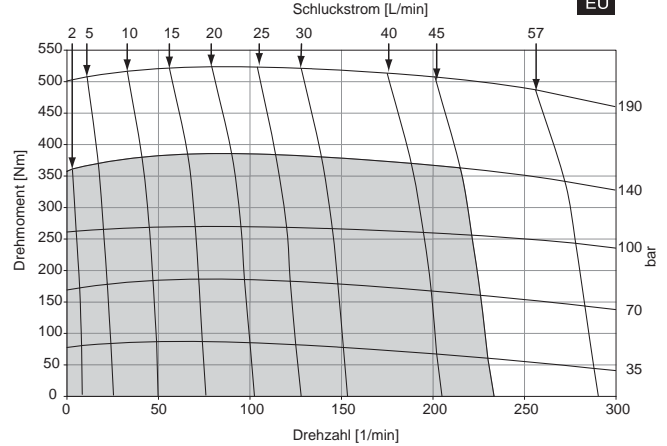

TORQUE (LB IN) 4631
SPEED (RPM) 111

Flow (GPM)

TE 0230 **13.9 cu in / rev** PRESSURE (PSID)

	500	1000	1500	1750	2000	2400
.5	761 7	1673 6	2614 5	3094 4	3584 3	4331 3
1	791 15	1712 14	2650 13	3128 12	3615 11	4366 9
2	819 32	1764 30	2726 29	3208 28	3692 26	4448 24
3	819 48	1771 47	2737 45	3226 44	3718 42	4482 41
4	821 65	1787 63	2765 61	3256 60	3750 58	4520 56
5	808 81	1786 79	2777 77	3277 76	3778 74	4554 73
7	770 114	1756 112	2755 109	3255 108	3760 106	4535 104
9	705 147	1699 145	2710 142	3216 140	3724 138	4496 137
12	581 197	1582 194	2595 191	3103 189	3617 186	4382 183
15	400 247	1409 243	2437 239	2949 237	3466 235	4216 230
20	64 329	1052 325	2067 321	2580 319	3100 316	3814 311

228 cc / rev

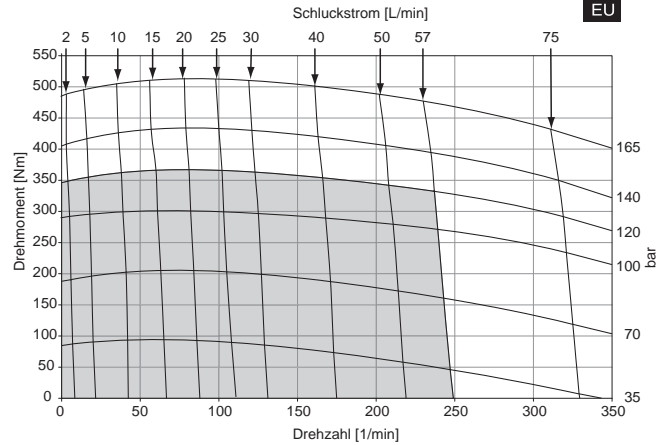

TORQUE (LB IN) 1894
SPEED (RPM) 198

Flow (GPM)

Cont.

Int.

Intermittent operation rating applies to 10% of every minute.
Fonctionnement interm. 10% max. de chaque minute d'utilisation.

Performance data based on testing using 10W40 oil with a viscosity of 200 SUS at 54° C (130° F). Performance data is typical. Actual data may vary slightly from one production motor to another.

Les donnees sur les performances sont basees sur des tests utilisant de l'huile 10W40 d'une viscosite de 200 SUS a 54°C (130°F). Ces donnees correspondent a des situations typiques. Les donnees reelles peuvent varier legerement d'un moteur de production a l'autre.

004 TE.indd, js

Intermittierende Werte maximal 10% von jeder Betriebsminute.

Capacidad de funcionamiento intermitente valida para 6 segundos por cada minuto.

Leistungsdaten sind gemessen mit SAE 10W40 bei einer Viskosität von 43,1 Cst bei 54°C. Geringfügige Abweichungen von den Katalogdaten sind möglich.

Datos tecnicos obtenidos con aceite 10W40 de 200 SUS de viscosidad a 54°C (130°F). Los datos proporcionados son valores tipicos. Los valores exactos reales podrian tener una pequena variacion entre distintos motores.

TE 0260 **15.9 cu in / rev** PRESSURE (PSID)

	500	1000	1500	1650	2250
.5	908 7	1961 6	3048 6	3380 6	4631 5
1	938 14	2006 13	3099 13	3433 12	4692 11
2	971 28	2059 27	3165 26	3501 26	4779 23
3	968 43	2065 42	3177 40	3514 39	4797 38
4	970 57	2081 56	3203 54	3541 53	4837 50
5	957 71	2084 70	3219 68	3561 67	4870 64
7	907 100	2049 98	3198 96	3542 95	4856 91
9	837 129	1985 127	3143 124	3489 123	4799 117
12	692 172	1844 169	3016 166	3367 164	4671 157
15	489 215	1647 212	2830 208	3188 206	4494 200
20	129 287	1255 283	2418 279	2773 277	4031 270

260 cc / rev

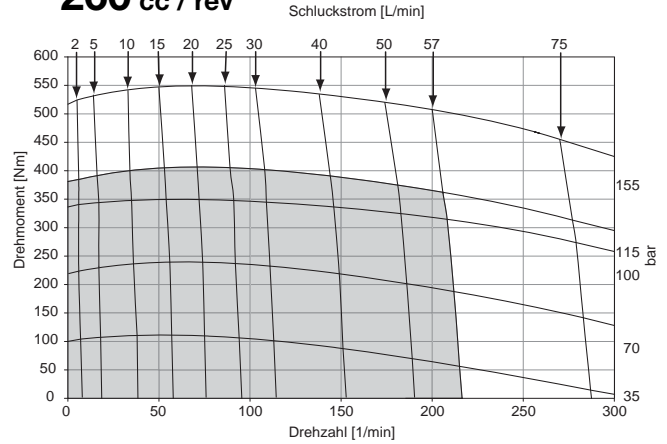

Flow (GPM)

TE 0295 **17.9 cu in / rev** PRESSURE (PSID)

	500	1000	1500	1550	2100
.5	1014 6	2216 5	3453 4	3576 4	4900 3
1	1051 12	2270 11	3509 10	3633 10	4963 8
2	1088 25	2334 24	3600 22	3727 22	5092 21
3	1085 38	2338 36	3611 35	3739 34	5110 33
4	1085 50	2353 49	3639 47	3769 47	5152 44
5	1072 63	2352 62	3654 60	3784 59	5180 57
7	1019 89	2311 87	3624 85	3755 84	5159 80
9	939 115	2237 113	3561 110	3693 110	5098 104
12	776 153	2074 151	3403 148	3537 147	4931 142
15	545 192	1853 189	3184 186	3319 185	4689 180
20	126 256	1408 253	2697 249	2826 249	4099 243

293 cc / rev

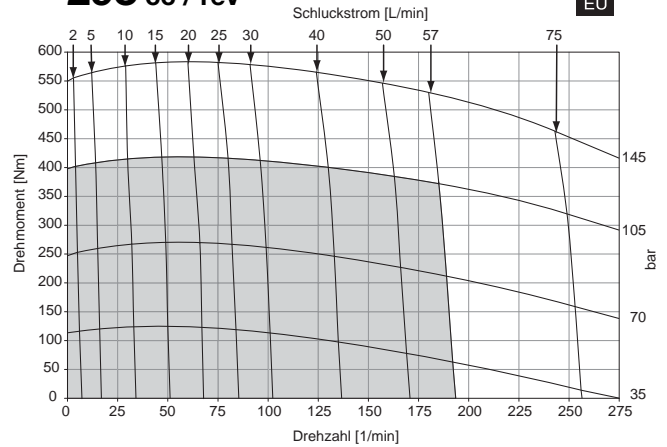

Flow (GPM)

■ Cont. □ Int.

Intermittent operation rating applies to 10% of every minute.
Fonctionnement interm. 10% max. de chaque minute d'utilisation.

Performance data based on testing using 10W40 oil with a viscosity of 200 SUS at 54° C (130° F). Performance data is typical. Actual data may vary slightly from one production motor to another.

Les données sur les performances sont basées sur des tests utilisant de l'huile 10W40 d'une viscosité de 200 SUS à 54°C (130°F). Ces données correspondent à des situations typiques. Les données réelles peuvent varier légèrement d'un moteur de production à l'autre.

Intermittierende Werte maximal 10% von jeder Betriebsminute.

Capacidad de funcionamiento intermitente valida para 6 segundos por cada minuto.

Leistungsdaten sind gemessen mit SAE 10W40 bei einer Viskosität von 43,1 Cst bei 54°C. Geringfügige Abweichungen von den Katalogdaten sind möglich.

Datos tecnicos obtenidos con aceite 10W40 de 200 SUS de viscosidad a 54°C (130°F). Los datos proporcionados son valores tipicos. Los valores exactos reales podrian tener una pequena variacion entre distintos motores.

TE 0330 **20.0 cu in / rev** PRESSURE (PSID)

	500	1000	1500	1950
.5	1184 5	2507 5	3722 4	5040 3
1	1218 11	2558 10	3772 9	5093 8
2	1258 22	2632 21	3867 20	5224 19
3	1251 34	2633 32	3879 31	5242 30
4	1249 45	2649 44	3909 42	5287 40
5	1229 57	2648 55	3926 53	5312 50
7	1162 80	2600 78	3898 75	5296 71
9	1064 103	2518 100	3829 98	5219 93
12	875 137	2333 135	3657 131	5026 127
15	621 171	2081 169	3420 165	4770 160
20	163 229	1576 226	2875 222	4129 214

TORQUE (LB IN) 5219
SPEED (RPM) 93

328 cc / rev

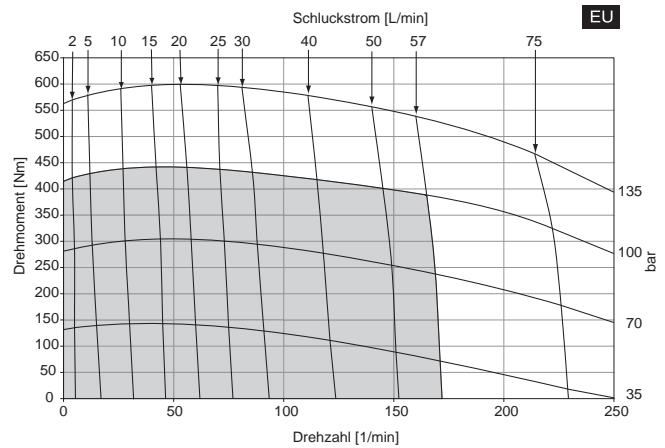

Flow (GPM)

TE 0365 **22.6 cu in / rev** PRESSURE (PSID)

	500	1000	1325	1825
.5	1393 5	2942 4	3974 4	5539 3
1	1444 10	3005 9	4036 8	5599 7
2	1494 20	3090 19	4131 18	5714 17
3	1485 30	3082 29	4125 28	5709 27
4	1477 40	3089 39	4139 37	5728 36
5	1452 50	3075 49	4130 47	5719 45
7	1371 70	3009 69	4071 67	5654 63
9	1260 90	2899 89	3669 87	5543 84
12	1002 121	2658 119	3737 117	5283 113
15	700 151	2355 149	3432 146	4937 142
20	152 201	1776 199	2838 196	4228 191

TORQUE (LB IN) 5543
SPEED (RPM) 84

370 cc / rev

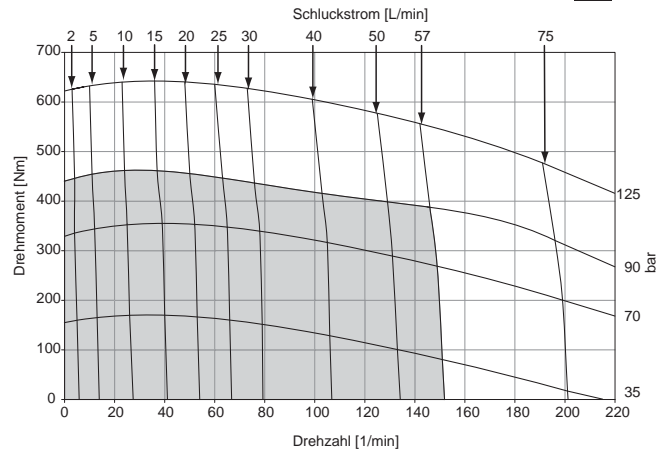

Flow (GPM)

Cont. Int.

Intermittent operation rating applies to 10% of every minute.

Fonctionnement interm. 10% max. de chaque minute d'utilisation.

Performance data based on testing using 10W40 oil with a viscosity of 200 SUS at 54° C (130° F). Performance data is typical. Actual data may vary slightly from one production motor to another.

Les donnees sur les performances sont basees sur des tests utilisant de l'huile 10W40 d'une viscosite de 200 SUS a 54°C (130°F). Ces donnees correspondent a des situations typiques. Les donnees reelles peuvent varier legerement d'un moteur de production a l'autre.

Intermittierende Werte maximal 10% von jeder Betriebsminute.

Capacidad de funcionamiento intermitente valida para 6 segundos por cada minuto.

Leistungsdaten sind gemessen mit SAE 10W40 bei einer Viskosität von 43,1 Cst bei 54°C. Geringfügige Abweichungen von den Katalogdaten sind möglich.

Datos tecnicos obtenidos con aceite 10W40 de 200 SUS de viscosidad a 54°C (130°F). Los datos proporcionados son valores tipicos. Los valores exactos reales podrian tener una pequena variacion entre distintos motores.

TE 0390 **24.0 cu in / rev** PRESSURE (PSID)

	500	1000	1250	1750
.5	1326 4	2889 3	3682 2	5244 2
1	1380 9	2934 7	3724 7	5283 6
2	1443 18	3034 17	3840 15	5427 13
3	1442 28	3049 26	3861 25	5458 22
4	1454 37	3084 36	3905 34	5518 32
5	1447 47	3104 45	3935 44	5562 40
7	1393 66	3080 64	3923 62	5559 60
9	1297 85	3013 83	3868 81	5507 79
12	1088 114	2818 112	3686 110	5308 106
15	797 143	2539 140	3414 138	5002 135
20	264 191	2006 188	2880 186	4374 182

392 cc / rev

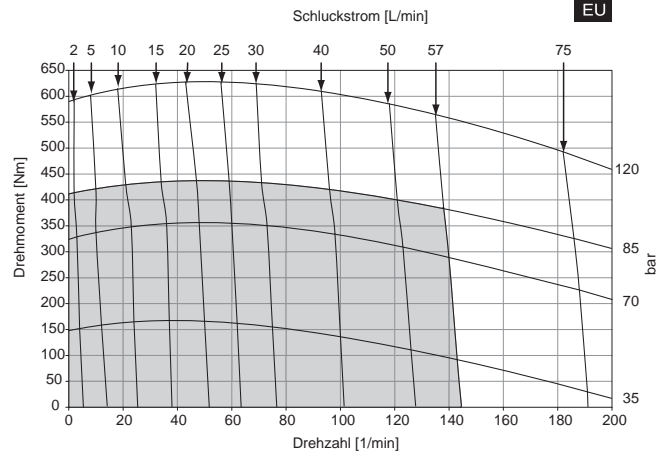

TORQUE (LB IN) 5559
SPEED (RPM) 60

Flow (GPM)

Cont.

Int.

Intermittent operation rating applies to 10% of every minute.

Fonctionnement interm. 10% max. de chaque minute d'utilisation.

Performance data based on testing using 10W40 oil with a viscosity of 200 SUS at 54° C (130° F). Performance data is typical. Actual data may vary slightly from one production motor to another.

Les donnees sur les performances sont basees sur des tests utilisant de l'huile 10W40 d'une viscosite de 200 SUS a 54°C (130°F). Ces donnees correspondent a des situations typiques. Les donnees reelles peuvent varier legerement d'un moteur de production a l'autre.

Intermittierende Werte maximal 10% von jeder Betriebsminute.

Capacidad de funcionamiento intermitente valida para 6 segundos por cada minuto.

Leistungsdaten sind gemessen mit SAE 10W40 bei einer Viskosität von 43,1 Cst bei 54°C. Geringfügige Abweichungen von den Katalogdaten sind möglich.

Datos tecnicos obtenidos con aceite 10W40 de viscosidad a 54°C (130°F). Los datos proporcionados son valores tipicos. Los valores exactos reales podrian tener una pequena variacion entre distintos motores.

Flange Mount / Standardgehaeuse
Monture à bride(s) / Montaje de brida

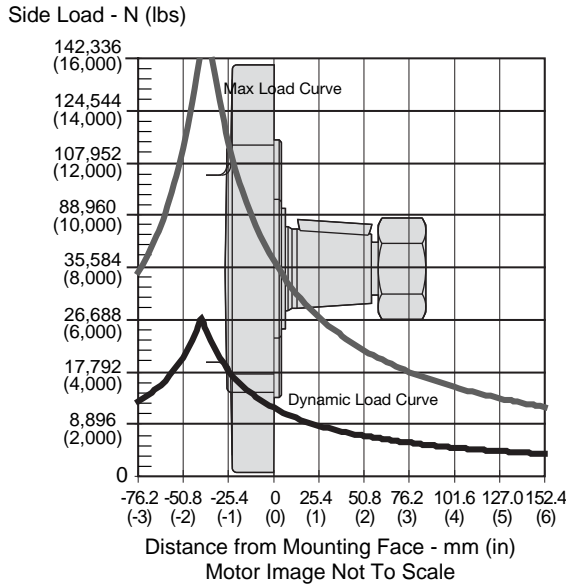

The dynamic side load curve is based on uni-directional steady state loads for L_{10} bearing life at 3×10^6 revolutions.

Die zulässige auslegbare radiale Wellenbelastungskurve ist unter ruhenden, einseitig statisch gerichteten Lastverhältnissen auf eine L_{10} Lebensdauer mit 3×10^6 Umdrehungen kalkuliert.
 La courbe de charge latérale permise se base sur des charges unidirectionnelles en régime permanent pour le roulement L_{10} à 3×10^6 révolutions.
 La curva de valores admisibles de carga lateral está basada en cargas constantes para cojinetes L_{10} a 3×10^6 revoluciones.

Wheel Mount / Radnabengehaeuse
Monture à roue / Montaje de rueda

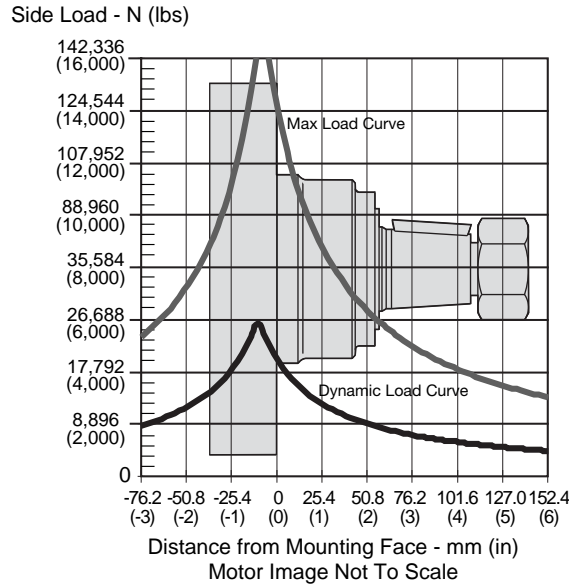

The maximum load curve is defined by bearing static load capacity. This curve should not be exceeded at any time including shock loads.

Die maximale radiale Wellenbelastungskurve ist definiert als maximale statische Last ohne Drehzahl. Sie gilt als Grenze und sollte keinesfalls überschritten werden.
 La courbe de charge maximale est définie par la capacité de charge statique portante. Cette courbe ne devrait être dépassée en aucun moment y compris pour les charges par à-coups.
 La curva de carga máxima queda definida por la capacidad de carga estática del cojinete. No se deben superar los valores de esta curva, ni siquiera con cargas provisorias de impacto.

Equation to Calculate the Expected Radial Bearing Life **Gleichung zur Ermittlung der Lagerlebensdauer**

Equation to calculate the dynamic bearing life for a given load:
Bestimmung der erlaubten radialen Wellenbelastung mit vorgegebener Last

Use F_a , F_b and S in equation to determine hours of L_{10} bearing life.
Die Lebensdauer in Stunden ergibt sich durch einsetzen von F_a , F_b , und S in die nachstehende Formel.

$$L = \frac{3.0 \times 10^6}{60 \times S} \left\{ \frac{F_a}{F_b} \right\}^{3.33}$$

Where / Mit:

S = Shaft Speed RPM / Abtriebswellendrehzahl in min^{-1}

L = Life In Hours / Lebensdauer in Stunden

F_a = Allowable side load defined by above curve at a distance from mounting flange. / Erlaubte radiale Wellenbelastung als Function der Laenge

F_b = Application side load. / Anwendungsseitige Wellenbelastung

Note: Calculations are based on L_{10} bearing life per ISO 281.
Auslegung basiert auf einer L_{10} Lebensdauer nach ISO 281

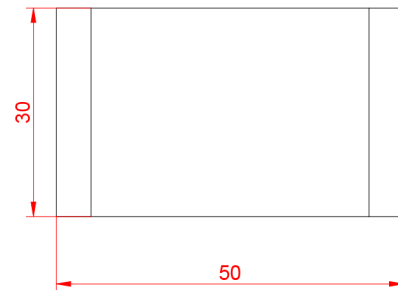
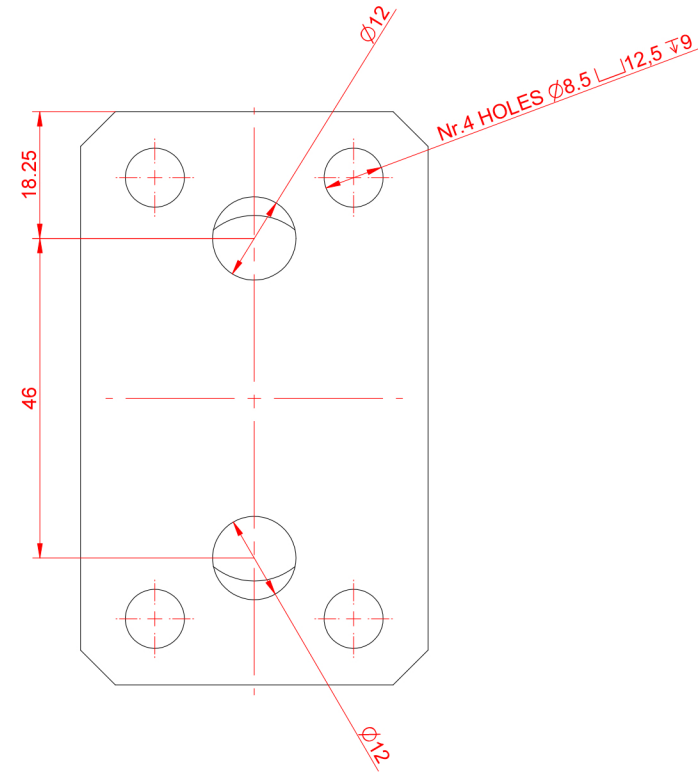
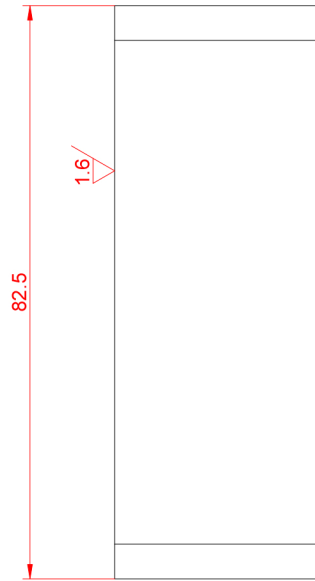
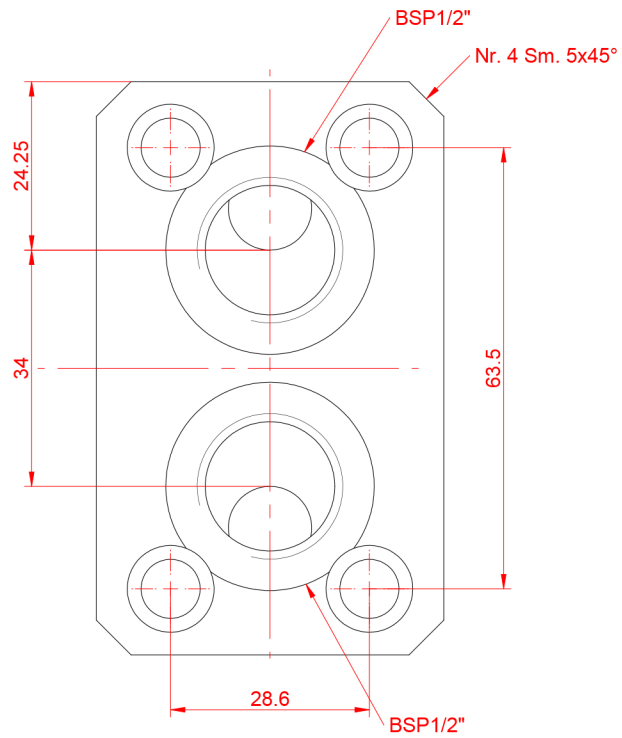

01	14/05/2019	MODIFIED BLOCK PROFILE	M. COLOMBO																																																																						
REV.	DATA REV.	DESCRIZIONE REVISIONE	FIRMA																																																																						
		TOLLERANZA DI CARPENTERIA ±1/1000 NON CUMULABILE	DIMENSIONI DEL GREZZO																																																																						
		TOLLERANZE GENERALI PER LAVORAZ. DI MACCHINA	TIPO MATERIALE																																																																						
		<table border="1"> <thead> <tr> <th>DA</th> <th>0</th> <th>6</th> <th>30</th> <th>120</th> <th>315</th> <th>1000</th> <th>2000</th> <th>OLTRE</th> <th>1°</th> </tr> </thead> <tbody> <tr> <td>A</td> <td>6</td> <td>30</td> <td>120</td> <td>315</td> <td>1000</td> <td>2000</td> <td>4000</td> <td>4000</td> <td>360°</td> </tr> <tr> <td>ALBERI</td> <td>0</td> <td>0</td> <td>0</td> <td>0</td> <td>0</td> <td>0</td> <td>0</td> <td>0</td> <td>0</td> </tr> <tr> <td></td> <td>-0.1</td> <td>-0.2</td> <td>-0.3</td> <td>-0.4</td> <td>-0.6</td> <td>-1</td> <td>-2</td> <td>-3</td> <td></td> </tr> <tr> <td>FORI</td> <td>0</td> <td>0</td> <td>0</td> <td>0</td> <td>0</td> <td>0</td> <td>0</td> <td>0</td> <td>20°</td> </tr> <tr> <td></td> <td>+0.1</td> <td>+0.2</td> <td>+0.3</td> <td>+0.4</td> <td>+0.6</td> <td>+1</td> <td>+2</td> <td>+3</td> <td></td> </tr> <tr> <td>ALTRE</td> <td>±0.05</td> <td>±0.1</td> <td>±0.15</td> <td>±0.2</td> <td>±0.3</td> <td>±0.5</td> <td>±1</td> <td>±1.5</td> <td></td> </tr> </tbody> </table>	DA	0	6	30	120	315	1000	2000	OLTRE	1°	A	6	30	120	315	1000	2000	4000	4000	360°	ALBERI	0	0	0	0	0	0	0	0	0		-0.1	-0.2	-0.3	-0.4	-0.6	-1	-2	-3		FORI	0	0	0	0	0	0	0	0	20°		+0.1	+0.2	+0.3	+0.4	+0.6	+1	+2	+3		ALTRE	±0.05	±0.1	±0.15	±0.2	±0.3	±0.5	±1	±1.5		TRATTAMENTI TERMICI
DA	0	6	30	120	315	1000	2000	OLTRE	1°																																																																
A	6	30	120	315	1000	2000	4000	4000	360°																																																																
ALBERI	0	0	0	0	0	0	0	0	0																																																																
	-0.1	-0.2	-0.3	-0.4	-0.6	-1	-2	-3																																																																	
FORI	0	0	0	0	0	0	0	0	20°																																																																
	+0.1	+0.2	+0.3	+0.4	+0.6	+1	+2	+3																																																																	
ALTRE	±0.05	±0.1	±0.15	±0.2	±0.3	±0.5	±1	±1.5																																																																	
		ELIMINARE SPIGOLI VIVI	PROF.T.T.A PEZZO																																																																						
		<table border="1"> <tr> <td>SPIGOLI SMUSSATI O RAGG.</td> <td>0.1-0.4</td> </tr> <tr> <td>RACCORDI CONCAVI</td> <td>0.2-0.8</td> </tr> <tr> <td>PARTI CON ASSI COMUNI</td> <td>0.2/360</td> </tr> <tr> <td>⊥ e // SUPERFICI-ASSI</td> <td>0.1/100</td> </tr> <tr> <td>⊥ e // SUPERFICI-SUPERFICI</td> <td>0.2/100</td> </tr> <tr> <td>□ PLANARITA'</td> <td>0.1/100</td> </tr> </table>	SPIGOLI SMUSSATI O RAGG.	0.1-0.4	RACCORDI CONCAVI	0.2-0.8	PARTI CON ASSI COMUNI	0.2/360	⊥ e // SUPERFICI-ASSI	0.1/100	⊥ e // SUPERFICI-SUPERFICI	0.2/100	□ PLANARITA'	0.1/100	DUREZZA																																																										
SPIGOLI SMUSSATI O RAGG.	0.1-0.4																																																																								
RACCORDI CONCAVI	0.2-0.8																																																																								
PARTI CON ASSI COMUNI	0.2/360																																																																								
⊥ e // SUPERFICI-ASSI	0.1/100																																																																								
⊥ e // SUPERFICI-SUPERFICI	0.2/100																																																																								
□ PLANARITA'	0.1/100																																																																								
		DATA 07/05/2019	FINITO																																																																						
		PESO FINITO -	TRATTAMENTO SUPERFICIALE																																																																						
		DIS. UTM	VERIFICATO -																																																																						
		DENOMINAZIONE DEL PARTICOLARE	SCALA																																																																						
		SPACER MANIFOLD	1:																																																																						
		GRUPPO -	FORM. UNI																																																																						
			A3																																																																						
			DISEGNO																																																																						
			PJ19206																																																																						
			REV.																																																																						
			01																																																																						