

**DETAILS FOR INSTALLATION HF600**

HF 500 Dimensions

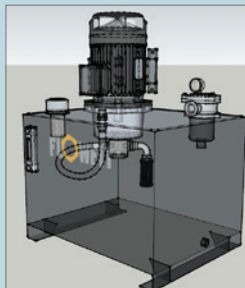
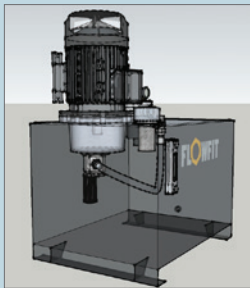
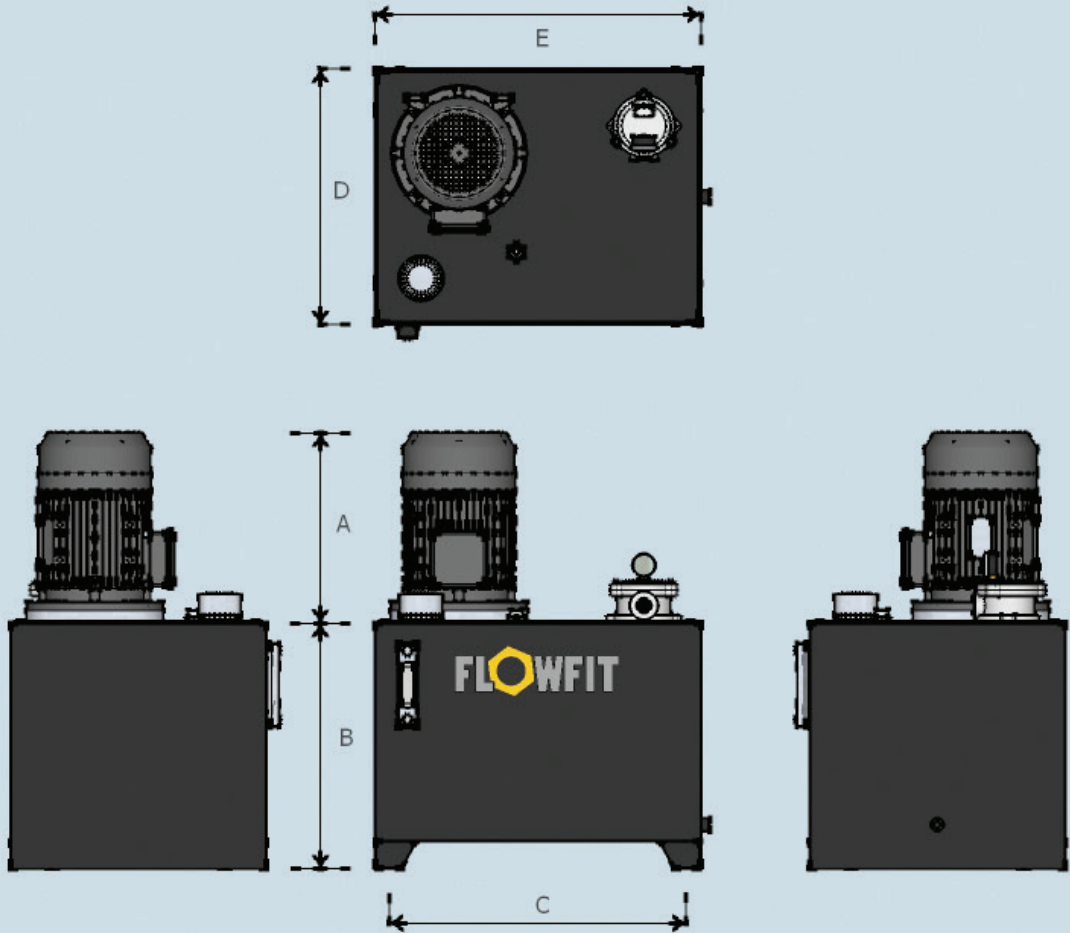

THREE PHASE ELECTRIC MOTOR DIMENSION		
MOTOR	FRAME	A
2.2-4.0 KW	D100/D112	326/335
5.5-7.5 KW	D132	305/420
11-15 KW	D160	510
18.5-22 KW	D180	590
30 KW	D200	660
37-45 KW	D225	705
55 KW	D250	730

TANK DIMENSIONS				
TANK CAPACITY	B	C	D	E
39 Litre	335	428	375	470
58 Litre	365	548	470	600
75 Litre	455	548	470	600
100 Litre	505	625	520	675
165 Litre	555	755	620	805
200 Litre	560	820	640	900
250 Litre	580	930	690	1010
300 Litre	580	1070	700	1150
400 Litre	580	1434	735	1514
630 Litre	770	1434	945	1514

SINGLE PHASE ELECTRIC MOTOR DIMENSION		
MOTOR	FRAME	A
2.2	D100	320
3 KW	D112	340