

Costruiti in lamiera di acciaio vengono forniti con coperchi, guarnizione e tappo di scarico.
La capacità nominale corrisponde a 2/3 della capacità totale.

Made in steel plate, they are supplied with covers and drain plug.
Nominal capacity corresponds to 2/3 of the total volume.

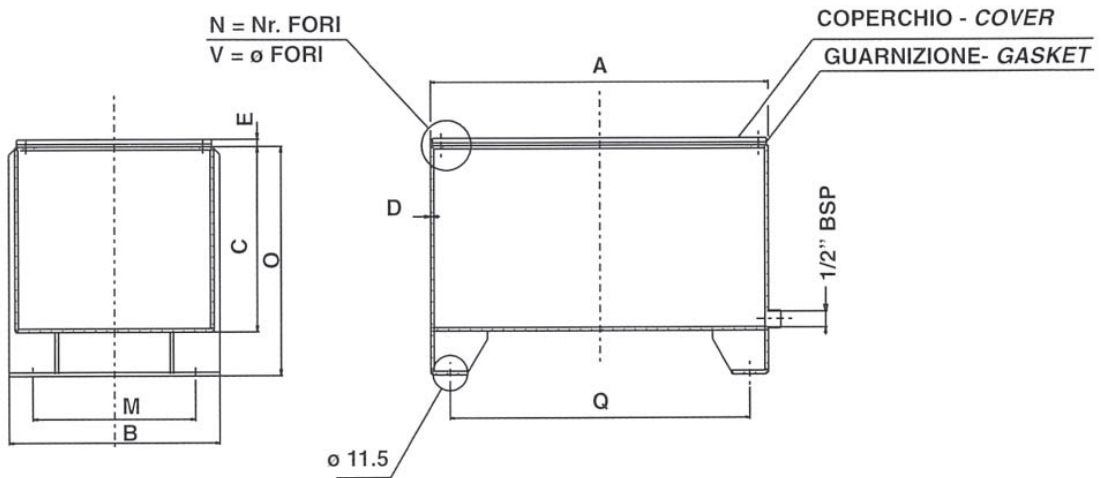

Codice ordinazione / How to order

Oil tank	Dimensioni / Dimensions (mm)								Fis. coperchio / Cover fixing	
	A	B	C	D	E	M	O	Q	N	V
	335	270	235	2	4	208	290	285	6	M8
	410	325	250	2	4	270	305	364	6	M8
	470	375	280	2	4	312	335	428	8	M8
	600	470	310	2,5	4	401	365	548	10	M8
	600	470	400	2,5	4	401	455	548	10	M8
	675	520	450	2,5	4	455	505	625	10	M8
	805	620	500	2,5	4	555	555	755	10	M8

FT series

Flanged and welded mounting filler breathers

Technical information

- Materials:**
- Cap: chrome plated steel
 - Basket: zinc plated steel
 - Flange: zinc plated steel
 - Gasket: cork

Filter media: Cellulose 10 - 40 μm



Ordering information

		MEDIA			
		C10	cellulose 10 μm		
		C40	cellulose 40 μm		
		MEDIA			
		C10	cellulose 10 μm		
		C40	cellulose 40 μm		
Filter assembly	NOMINAL SIZE	MEDIA	MOUNTING TYPE	PRESSURIZING VALVE	PADLOCK HOLDER
FT	8	C10	/2	V07	L
				MOUNTING TYPE	
		--	FT-5 only		
		/1	flange, basket L 80		
		/2	flange, basket L 150		
		/F	flange, removable basket		
		/G	welding flange		
		/S	with antisplash tube		
				PRESSURIZING VALVE	
		000	no pressurizing valve		
		*V03	0,35 bar / 5 psi		
		*V07	0,75 bar / 10,8 psi		
				PADLOCK HOLDER	
		0	no padlock holder		
		*L	with padlock holder		

*FT-8 only, see page 10

*FT-8 only, see page 10

FLANGE MOUNTING

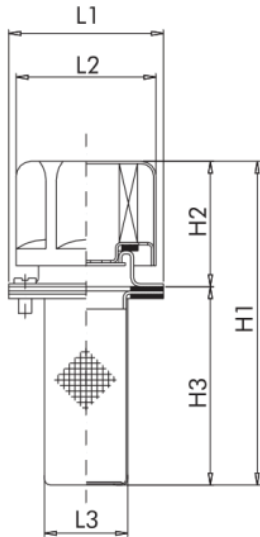
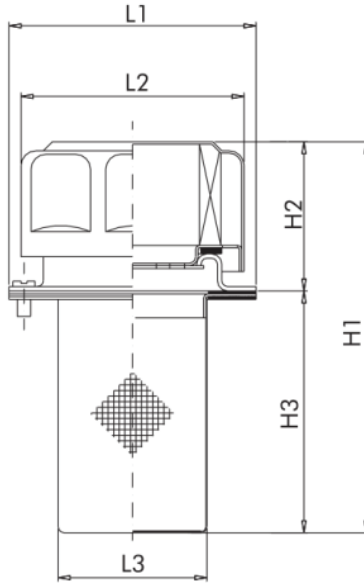
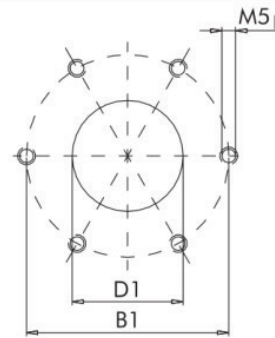
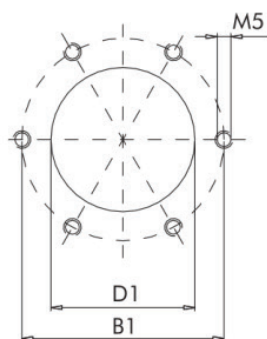
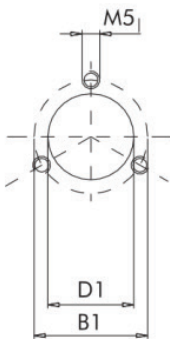
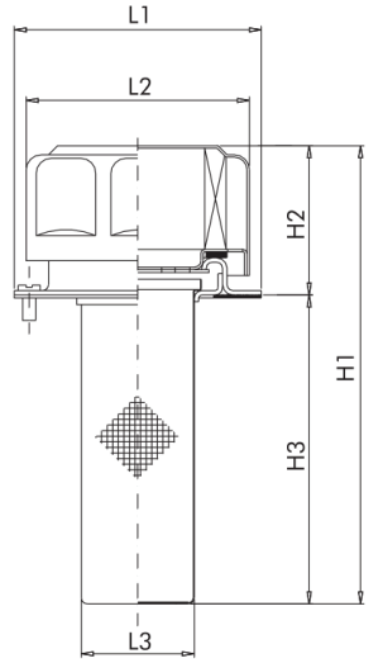
FT-5

FT-8/1 - FT-8/2

FT-8/F

Nominal size

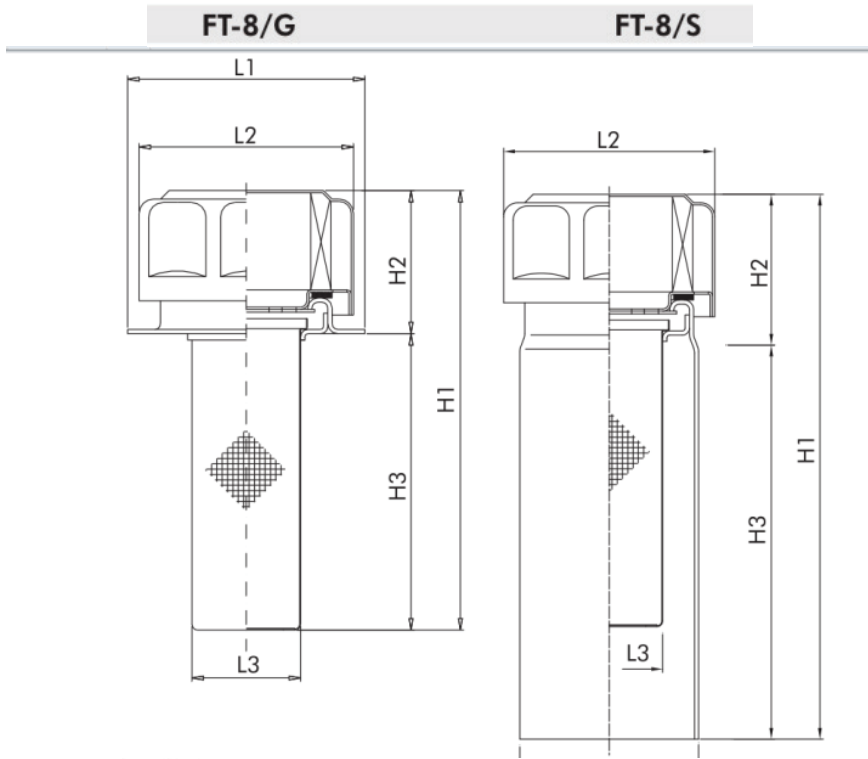
CODE	B1	D1	H1	H2	H3	L1	L2	L3	SAFETY CHAIN
FT-5	41	31	107	42	65	52	47	27,5	no
FT-8-.../1	73	52	130	50	80	83	75	50	yes
FT-8-.../2			200		150				yes
FT-8-.../F		40	150		100				no

WELDED MOUNTING



Nominal size

CODE	D1	H1	H2	H3	L1	L2	L3	SAFETY CHAIN
FT-8-.../G	40	150	50	100	83	75	38	no
FT-8-.../S	64	183		133	63,5			

Options

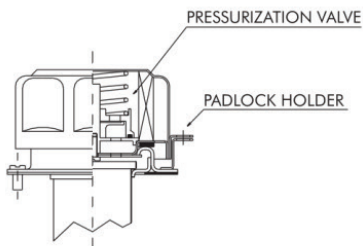

The FT-8 filler breathers can be supplied on request with some optional device:

- PRESSURIZATION VALVE
- PADLOCK HOLDER

N.B. FT-8/1 and /2 are equipped with a safety chain to avoid accidental loss of the cap



FILTRAZIONE IDRAULICA
HYDRAULIC FILTRATION



FILTREC[®]
Technical Filtration

serie
FR-1



Serie FR-1

Filtri sul ritorno Return filter



FILTER HOUSING

Description:
Max flow rate:
Max working pressure:
Test pressure:
Burst pressure:
Connection Ports:
Indicator:
Working temperature:
Materials:

Fluids compatibility:
 ISO 2943: Filter assembly compatible with mineral oils and some synthetic or vegetable oils. With other fluid applications please contact Filtrac S.p.A.

FILTER ELEMENT

Filter media:

Collapse pressure:
By-pass:

Technical Information

Tank top mounting design return line with reusable or disposable element.
 600 l/min (158 gpm)

As per NFPA T 3.10.5.1: 8 Bar (116 psi)

As per NFPA T 3.10.5.1: 12 Bar (174 psi)

As per NFPA T 3.10.5.1: 16 Bar (232 psi)

BSP, NPT, SAE J514b

Visual and electrical.

-25°C +100°C (-13°F +212°F)

- Cover: aluminium
- Head: aluminium
- Bowl: nylon - carbon steel
- Seal: Buna-N / Viton®

ISO 2943: Filter assembly compatible with mineral oils and some synthetic or vegetable oils. With other fluid applications please contact Filtrac S.p.A.

Microglass fiber 3,6,10,25 µm

Cellulose 10,25 µm

Wire mesh 60, 125 µm

As per ISO 2941: 10 Bar (145 psi)

Return line 1,7 Bar (24.6 psi)

Informazioni dimensionali - Overall dimensions

FR1-1-10 / 11 / 20 / 22 / 30

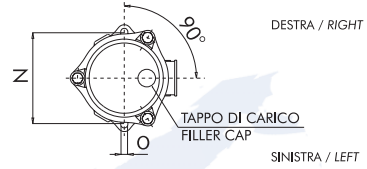
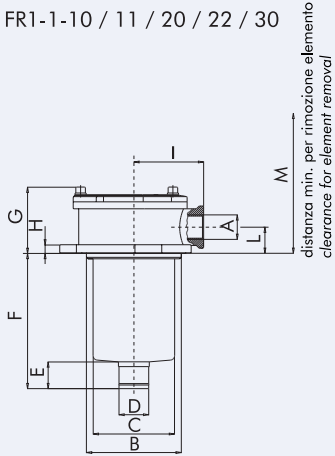

FORATURA SERBATOIO
TANK HOLE DIMENSIONS

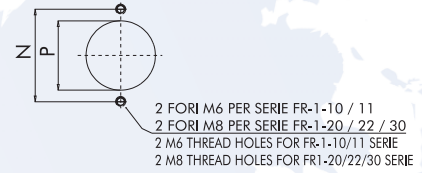

FR1-1-40 / 43

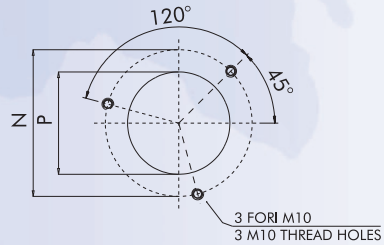
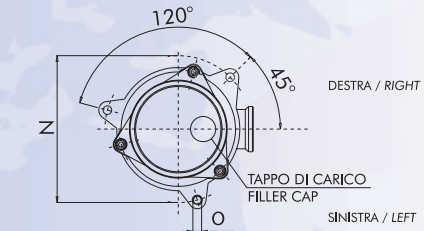
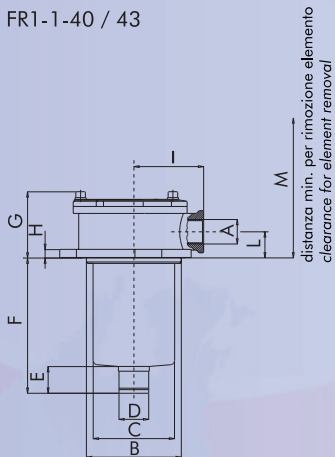

FR-1-1-50 / 51 / 60 / 64

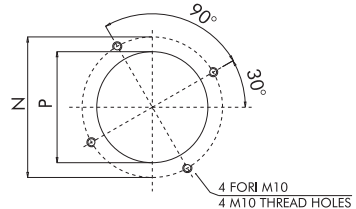
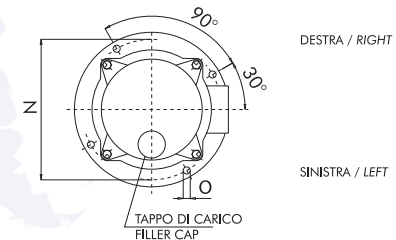
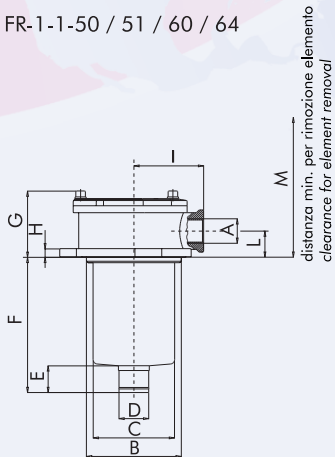

1) Grandezza nominale - Nominal size

Codice - Code	A	B	C	D	E	F	G	H	I	L	M	N	O	P	Cart. ricambio - Element
FR-1-10	3/8" - 1/2" - 3/4" BSP	66,5	62	24	22	83	54	8	51	20,5	150	89±1	7	67,5	R-1-10
	3/8" - 1/2" - 3/4" NPT														
FR-1-11	9/16" - 18 UNF - SAE J514b	66,5	62	24	22	152	54	8	51	20,5	220	89±1	7	67,5	R-1-11
	3/4"-16 UNF - SAE J514b 1 1/16"-12 UN-SAE J514b														
FR-1-20	1/2" - 3/4" BSP	87,5	80	27,5	27	106	73	11	67	28,5	190	115±1	8,5	88,5	R-1-20
	1/2" - 3/4" NPT														
FR-1-22	3/4" - 1" BSP	87,5	80	27,5	27	151	73	11	67	28,5	230	115±1	8,5	88,5	R-1-22
	3/4" - 1" NPT														
FR-1-30	1 1/16"-12 UN-SAE J514b	87,5	80	40	29	232	73	11	67	28,5	310	115±1	8,5	88,5	R-1-30
	1 5/16"-12 UN-SAE J514b														
FR-1-40	1" - 1 1/4" - 1 1/2" BSP	129	111	40	36	230	87	11	95	35,5	320	175	11	130	R-1-40
	1" - 1 1/4" - 1 1/2" NPT														
FR-1-43	1 5/16"-12 UN-SAE J514b	129	111	40	36	273	87	11	95	35,5	360	175	11	130	R-1-43
	1 5/8"-12 UN-SAE J514b 1 7/8"-12 UN-SAE J514b														
FR-1-50	1 1/4" - 1 1/2" - 2" BSP	174	151	50	41	171	108	11	119	41	270	220	11	175	R-1-50
	1 1/4" - 1 1/2" - 2" NPT														
FR-1-51	1 5/8"-12 UN-SAE J514b	174	151	50	41	238	108	11	119	41	340	220	11	175	R-1-51
FR-1-60	1 7/8"-12 UN-SAE J514b	174	151	64	41	238	108	11	119	41	340	220	11	175	R-1-60
	2 1/2"-12 UN-SAE J514b														
FR-1-64	1 1/2" - 2" BSP	174	151	64	41	298	108	11	119	41	380	220	11	175	R-1-64
	1 1/2" - 2" NPT														
	1 7/8"-12 UN-SAE J514b 2 1/2"-12 UN-SAE J514b														

2) Grado di filtrazione - Filtration ratings

Codice - Code	Materiale - Media	Efficienza - Efficiency
0	senza cartuccia / no element	-----
G03	microfibra inorganica / microglass fiber	$\beta_{4,5 \mu\text{m} (c)} \geq 1000$
G06	microfibra inorganica / microglass fiber	$\beta_{7 \mu\text{m} (c)} \geq 1000$
G10	microfibra inorganica / microglass fiber	$\beta_{12 \mu\text{m} (c)} \geq 1000$
G25	microfibra inorganica / microglass fiber	$\beta_{27 \mu\text{m} (c)} \geq 1000$
C10	carta trattata / resin impregnated cellulose	$\beta_{10 \mu\text{m} (c)} \geq 2$
C25	carta trattata / resin impregnated cellulose	$\beta_{25 \mu\text{m} (c)} \geq 2$
T60	tela metallica / wire mesh	-----
T125	tela metallica / wire mesh	-----

3) Guarnizioni - Seals

Codice - Code	Tipo - Type
---	NBR
V	Viton®

4) Connesioni - Connection port

Codice - Code	Connessione - Connection
B2	3/8" BSP
B3	1/2" BSP
B4	3/4" BSP
B5	1" BSP
B6	1 1/4" BSP
B7	1 1/2" BSP
B8	2" BSP
N2	3/8" NPT
N3	1/2" NPT
N4	3/4" NPT
N5	1" NPT
N6	1 1/4" NPT
N7	1 1/2" NPT
N8	2" NPT
R2	9/16" - 18 UNF-2B SAE J514b
R3	3/4" - 16 UNF-2B SAE J514b
R4	1 1/16" - 12 UN-2B SAE J514b
R5	1 5/16" - 12 UN-2B SAE J514b
R6	1 5/8" - 12 UN-2B SAE J514b
R7	1 7/8" - 12 UN-2B SAE J514b
R8	2 1/2" - 12 UN-2B SAE J514b

5) Tappo di carico - Filler cap

Codice - Code	Tipo - Type
0	senza / without
T	con / with

6) Posizione indicatore Indicator position

Codice - Code	Posizione - Position
0	senza / without
C	coperchio / cover *
D	destra / right **
S	sinistra / left

* Non disponibile per FR-1-10 con tappo di carico

* Not available for FR-1-10 with filler cap

** Non disponibile per FR-1-1x ed FR-1-4x

** Not available for FR-1-1x and FR-1-4x

7) Indicatori - Indicators

Codice Code	Tipo indicatore - Indicator type	Taratura Setting
0	senza / without	
R1	manometro scala pressure gauge indicator scale	0 ÷ 10 Bar 0 ÷ 145 psi
R2	pressostato n.a. taratura pressure switch O.C.	1,3 Bar 18,85 psi O.C.
R3	pressostato n.c. taratura pressure switch C.C.	1,3 Bar 18,85 psi C.C.
R6	pressostato visivo visual pressure	1,2 Bar 17,4 Psi
R7	manovuotometro taratura pressure vacuum gauge	-1 ÷ 5 Bar -14,5 ÷ 72,5 Psi

Codici per l'ordinazione - Ordering information

Filtro completo
Filter assembly

FR-1

20	C10	B	V	B3	T	C	R1
1*	2*		3*	4*	5*	6*	7*

Cartuccia
Filter element

R-1

20	C10	B	V
1*	2*		3*

Curve di portata - Pressure drop charts

Le curve (secondo ISO 3968 classe B) sono ottenute con olio minerale avente viscosità di 30 cSt e densità di 0,86 Kg/dm³. Per viscosità e densità diverse i dati variano.

Il numero relativo alla curva di portata è riferito all'attacco del filtro; es.: 2 indica attacco B2 o N2.

Pressure drop charts (as per ISO 3968 class B) are obtained using mineral oil with 30 cSt viscosity and 0,86 Kg/dm³ density. With different values of viscosity and density data may vary.

The numbers indicate connection of the filters: i.e. 2 means B2 or N2 connections.

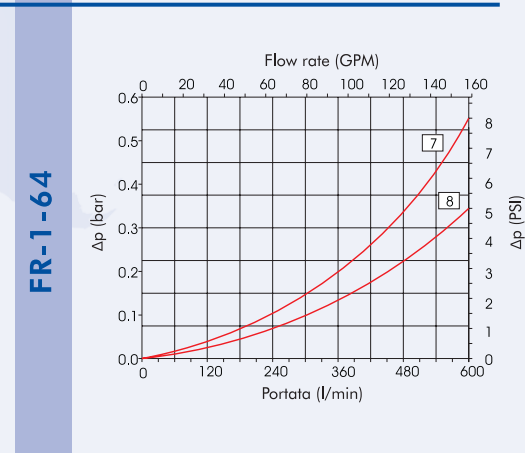
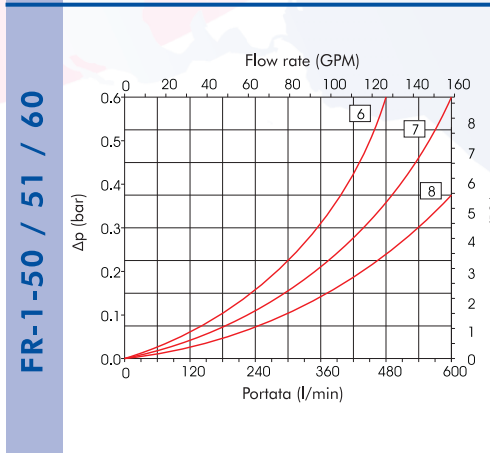
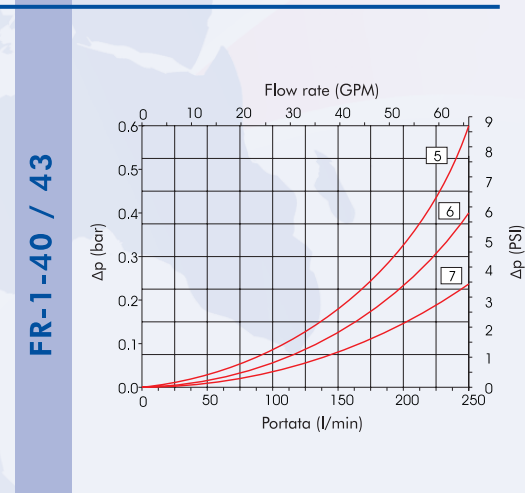
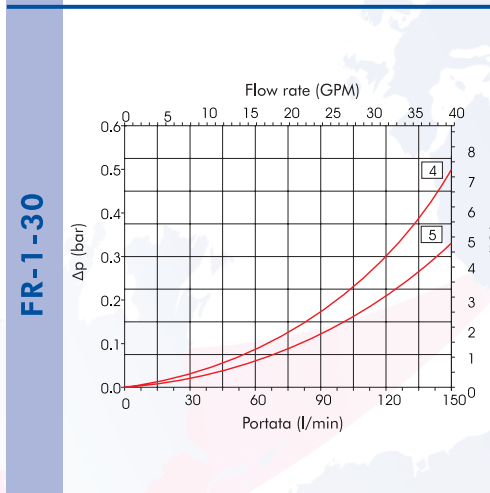
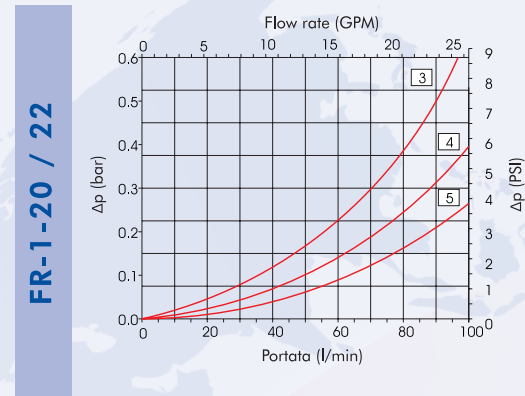
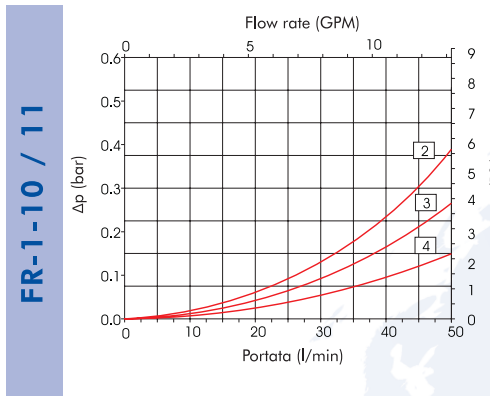

R-1-10

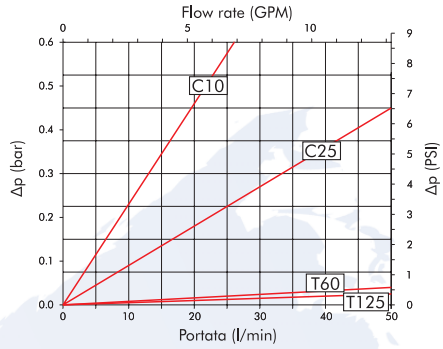
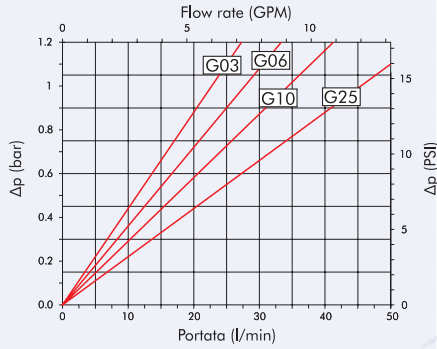

R-1-11

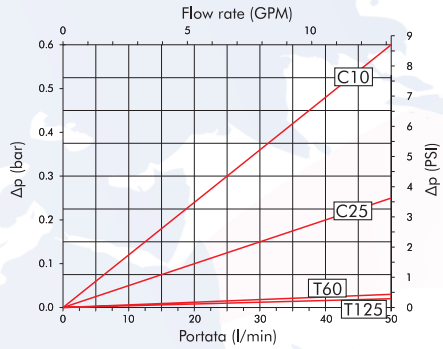
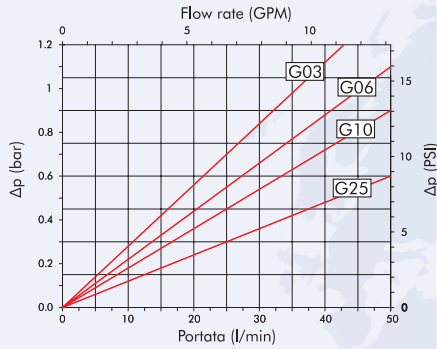

R-1-20

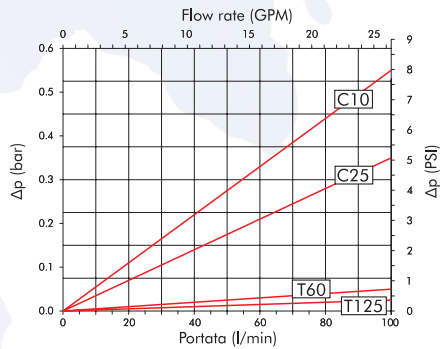
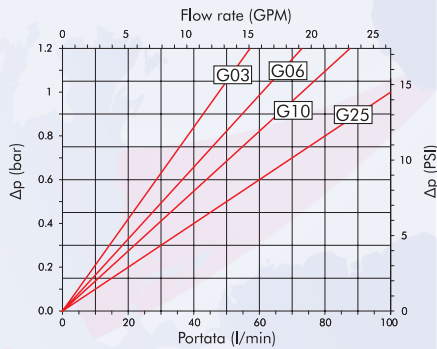

R-1-22

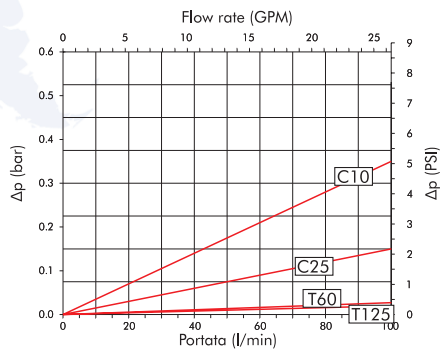
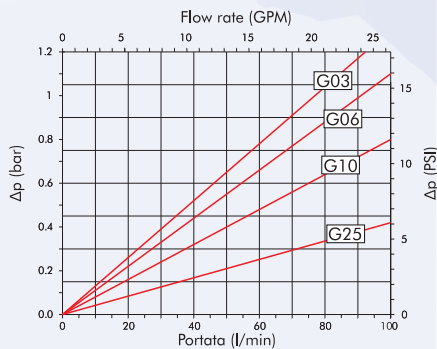

R-1-30

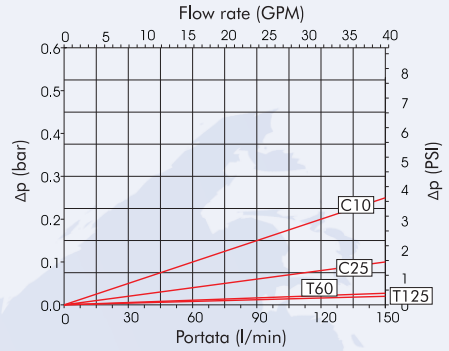
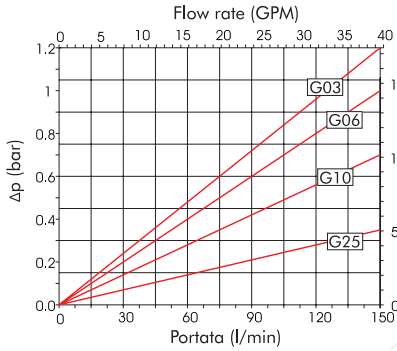

R-1-40

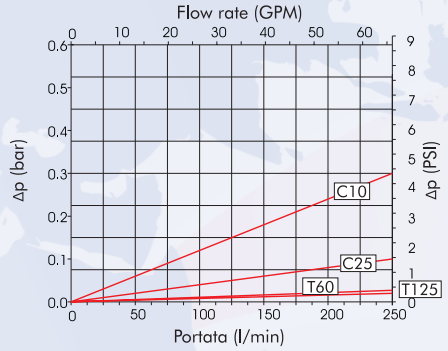
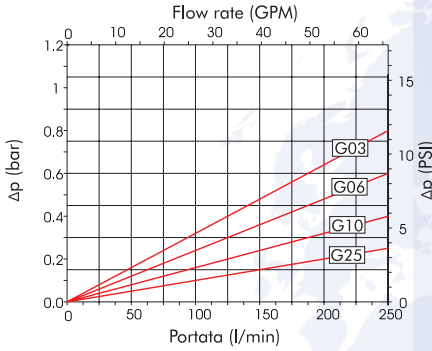

R-1-43

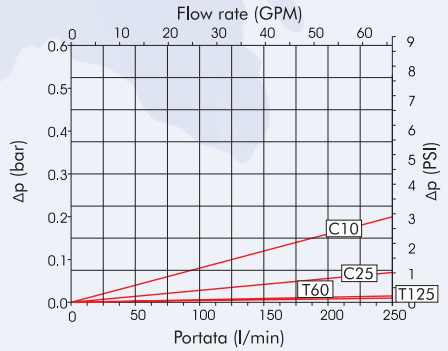
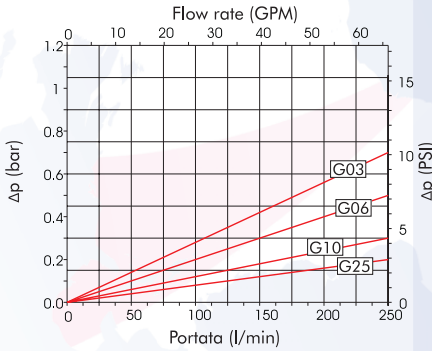

R-1-50

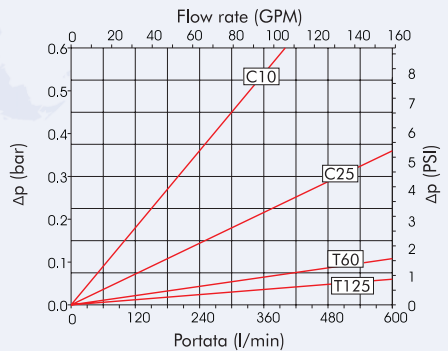
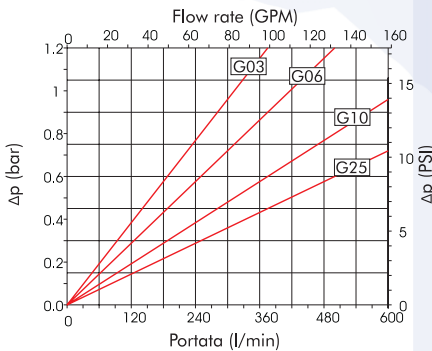

R-1-51

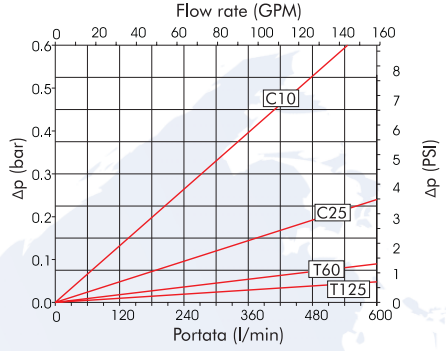
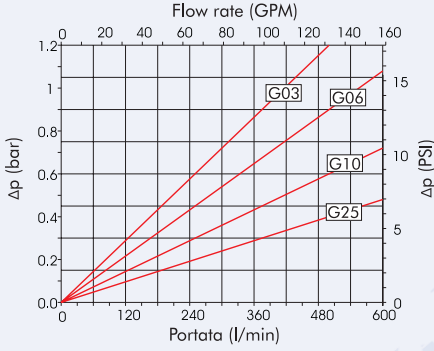

R-1-60

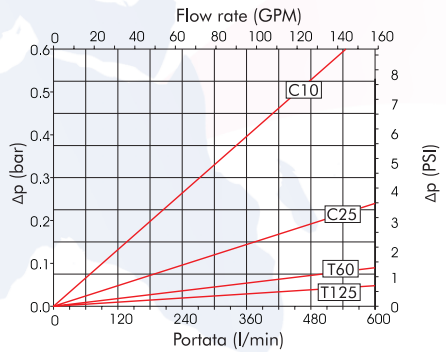
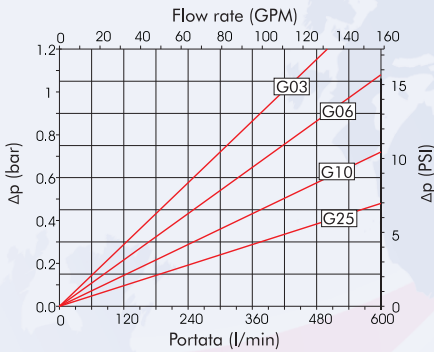

R-1-64

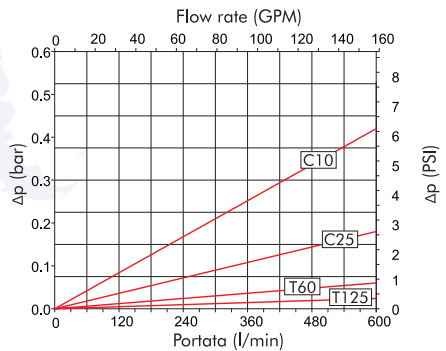
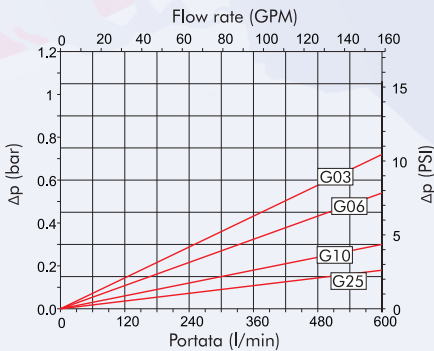



 
ACCESSORI
ACCESSORIES



FILTREC[®]
Technical Filtration

serie
FL



Serie FL

Indicatori visivi di livello per fluidi
Fluid level temperature gauges



FILTER HOUSING

Description:

Max working pressure:

Connection Ports:

Working temperature:

Thermometer:

Materials:

Technical Information

Fluid level temperature gauges

1 Bar (14.5 psi)

Metric

-20°C +80°C (-4°F +176°F)

Double scale 0°C ÷ 100°C 30°F ÷ 210 °F

- Heads: nylon
- Protection: anodized aluminium
- Screws: zinc steel
- Seal: Buna-N

compatible as per ISO 2943 with
 mineral oil (HH-HL-HM-HR-HV-HG)
 water oil emulsions (HFAE-HFAS)

Informazioni dimensionali - Overall dimensions

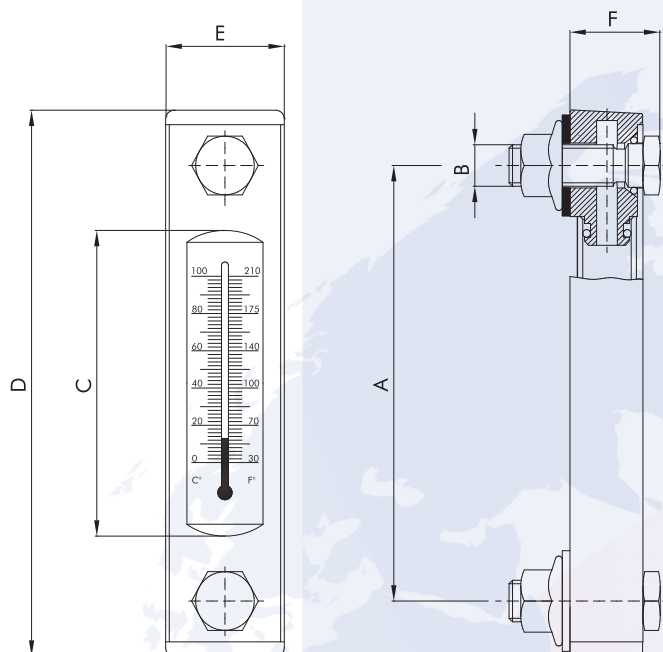

1) Grandezza nominale - Nominal size

Codice - Code	A	B	C	D	E	F
FL-1	76	M10	35	106	36	30
FL-2	127		86	157	36	30
FL-3	254	M12	213	284	36	30

2) Termometro - Temperature indicator

Codice - Code	Termometro - Temperature indicator
0	senza / without
T	con / with

3) Conessioni - Connection port

Codice - Code	Connessione - Connection
M10	M10
M12	M12

Codici per l'ordinazione - Ordering information

FL-2	T	M12
1*	2*	3*

Weldless Steel Tanks for Hydraulic Power Units





Weldless Steel Tanks for Hydraulic Power Units

Table of Contents

	Page No.
Overview.....	4
Steel Tanks 6 Lt. Type A (1,6 Gallon) Dimensional Data	5
Steel Tanks 6 Lt. Type B (1,6 Gallon) Dimensional Data	6
Steel Tanks 12 Lt. Type A (3,2 Gallon) Dimensional Data	7
Steel Tanks 12 Lt. Type B (3,2 Gallon) Dimensional Data	8
Steel Tanks 25 Lt. (6,6 Gallon) Dimensional Data	9
Steel Tanks 40 Lt. (10,6 Gallon) Dimensional Data	10
Steel Tanks 70 Lt. Type A (18,5 Gallon) Dimensional Data	11
Steel Tanks 70 Lt. Type B (18,5 Gallon) Dimensional Data	12
Steel Tanks 70 Lt. Type C (18,5 Gallon) Dimensional Data	13
Steel Tanks 100 Lt. Type A (26,4 Gallon) Dimensional Data	14
Steel Tanks 100 Lt. Type B (26,4 Gallon) Dimensional Data	15
Steel Tanks 100 Lt. Type C (26,4 Gallon) Dimensional Data	16
Steel Tanks 160 Lt. Type A (42,3 Gallon) Dimensional Data	17
Steel Tanks 160 Lt. Type B (42,3 Gallon) Dimensional Data	18
Steel Tanks 160 Lt. Type C (42,3 Gallon) Dimensional Data	19
Steel Tanks 250 Lt. Type A (66,0 Gallon) Dimensional Data	20
Steel Tanks 250 Lt. Type B (66,0 Gallon) Dimensional Data	21
Steel Tanks 250 Lt. Type C (66,0 Gallon) Dimensional Data	22
Weights Chart.....	23
Lid Layout Dimensions for Bellhousing	24
Price list	25-28



Steel Tanks for Hydraulic Power Units Overview

Weldless Steel Tanks

FLOWFIT offers a complete line of hydraulic tanks and tanks accessories for fluid power transmission applications. The line includes Weldless Steel tanks complete lids, sealing gaskets, legs and associated parts for tanks including a complete line of oil level gauges, bellhousings, filler breather etc... for routing hydraulic lines directly into the tank.

WELDLESS SHEET METAL OIL TANK FEATURES

- All FLOWFIT Weldless Steel Tank bodies are skillfully fabricated from high strength cold rolled steel plate and sheet.
- Produced by the deep drawing method of forming the body of the tank without the use of welding in all circumstances guarantee 100% leak
- Hydraulic Power Unit with a capacity of eight different applications respond to a large part,
- Light weight and high strength weldless sheet metal tank body,
- Tank body with electrostatic epoxy-polyester powder paint (Phosphate-coated on the surface) and the high strength obtained by painting the surface quality and protection. (standard color RAL 5007 Brillant blue)
- Assembled as an oil level indicator (option), Tank can be installed over the drain plug (standard) shipping,
- Lid - Tank is an integrated view after assembly to give the vibration damping and sealing gasket feature (NBR 70)
- Lid - Standard colour RAL 9005

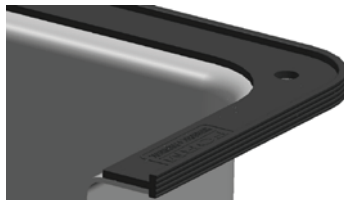
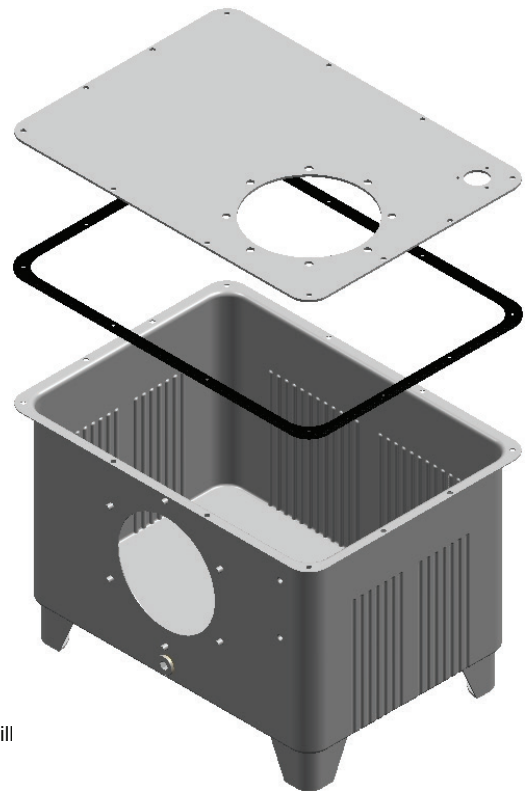

- + Traps oil leaks prevents spill
- + Reduces noise
- + Absorbs vibration
- + Compatible with most fluids
- + Simplifies assembly

- Different tank lid designs available upon request, please always ask.
- Its strength, light weight, compact design, with the advantage of immediate delivery from stock at unbeatable price



Steel Tanks for Hydraulic Power Units 6 Litre Type A Dimensional Data

Weldless Steel Tank 6 Litre Type A (1,6 Gallon)

mm [in]

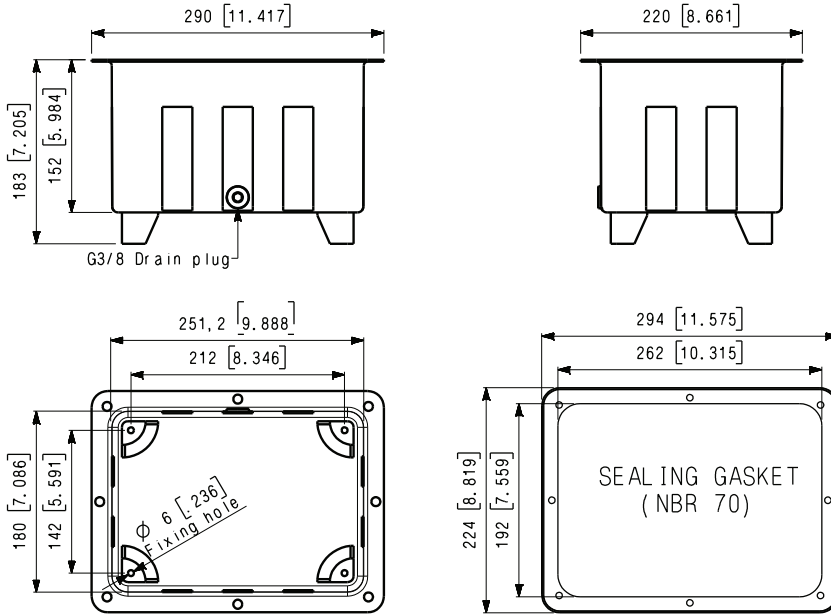

Lid 6 Litre (1,6 Gallon)

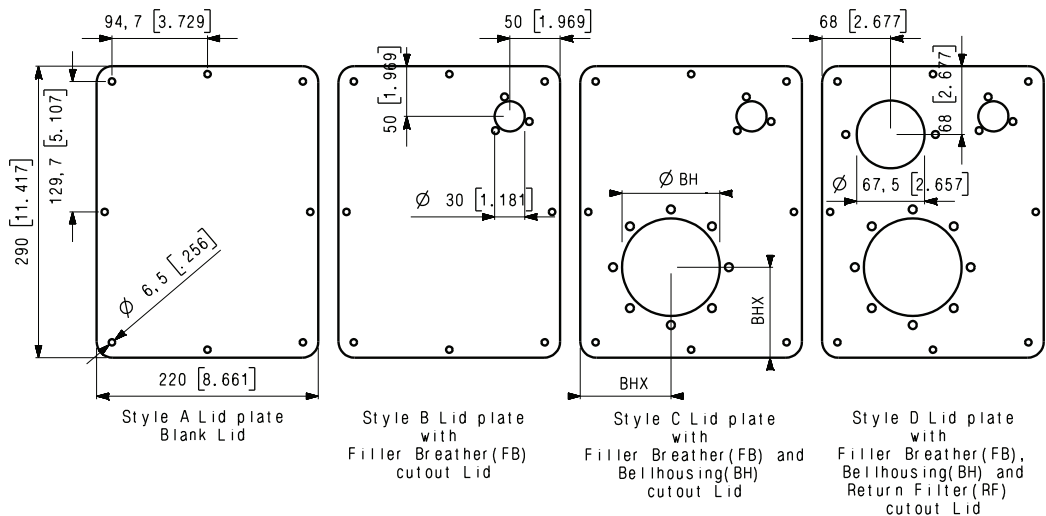

See page 25 for price list

FLOWFIT reserves the right to change specifications and information without notice.

FLOWFIT® TECHNICAL DATA SHEET



Steel Tanks for Hydraulic Power Units 6 Litre Type B Dimensional Data

Weldless Steel Tank 6 Litre Type B (1,6 Gallon)

mm [in]

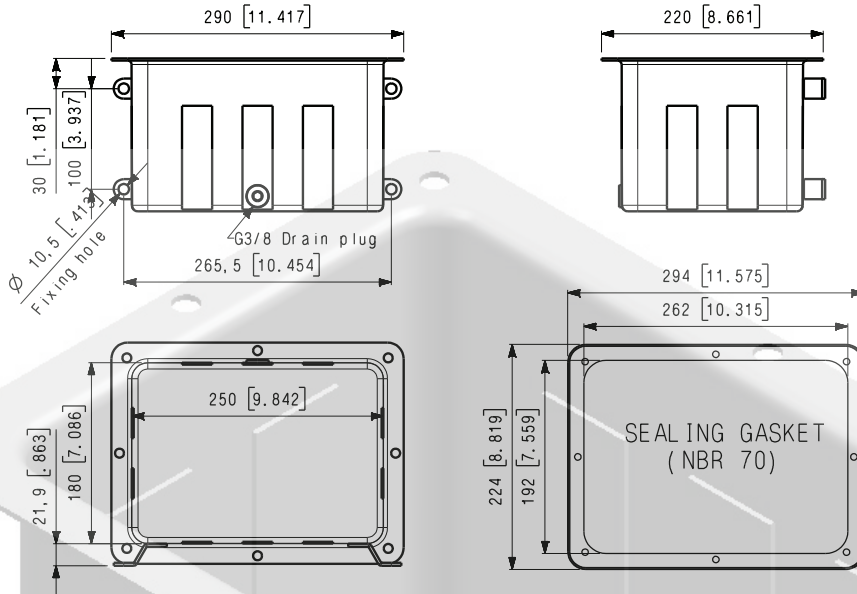

Lid 6 Litre (1,6 Gallon)

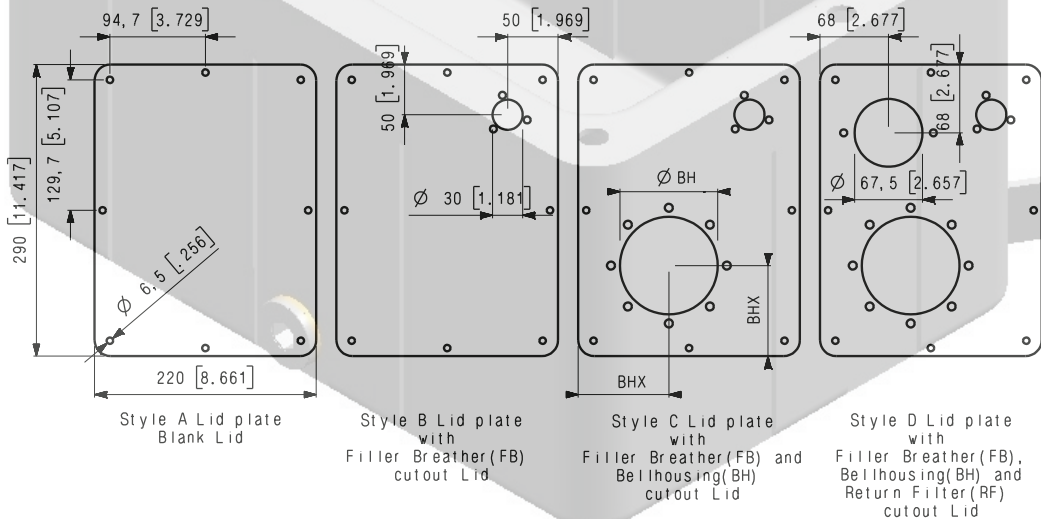

See page 25 for price list

FLOWFIT reserves the right to change specifications and information without notice.



Steel Tanks for Hydraulic Power Units 12 Litre Type A Dimensional Data

Weldless Steel Tank 12 Litre Type A (3,2 Gallon)

mm [in]

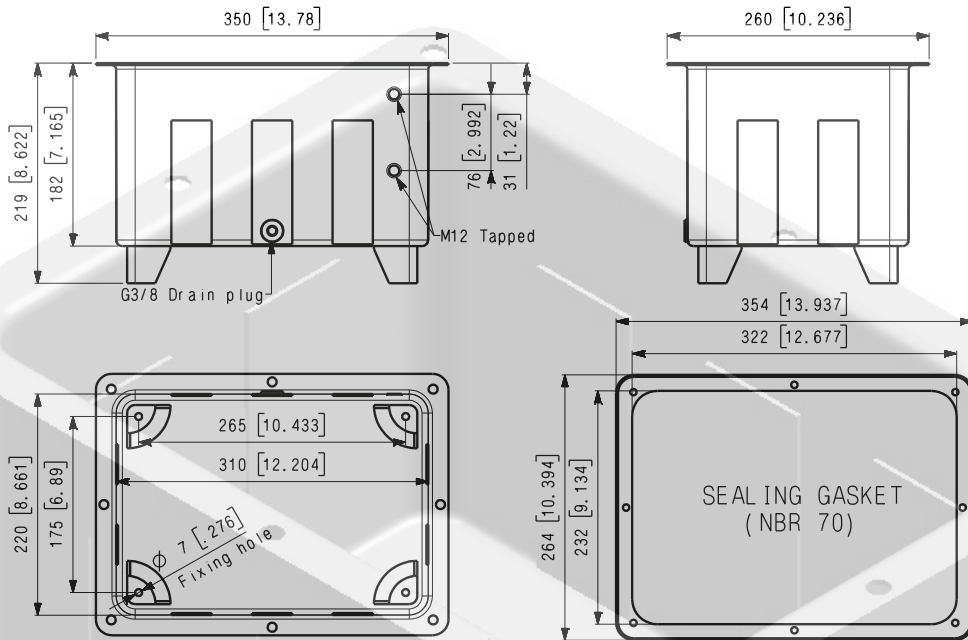

Lid 12 Litre (3,2 Gallon)

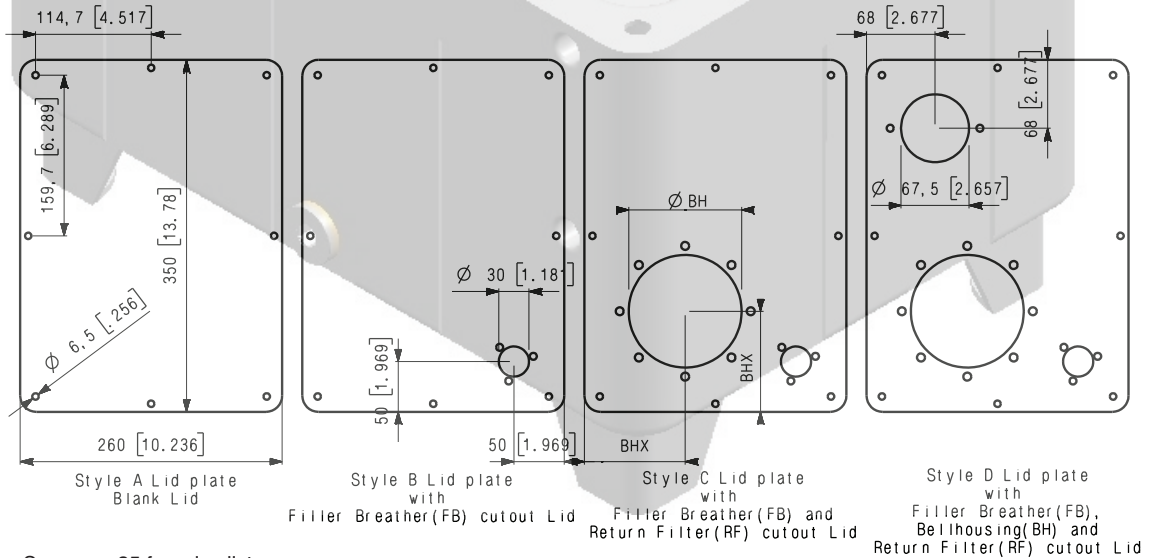

See page 25 for price list

FLOWFIT reserves the right to change specifications and information without notice.



Steel Tanks for Hydraulic Power Units 12 Litre Type B Dimensional Data

Weldless Steel Tank 12 Litre Type B (3,2 Gallon)

mm [in]

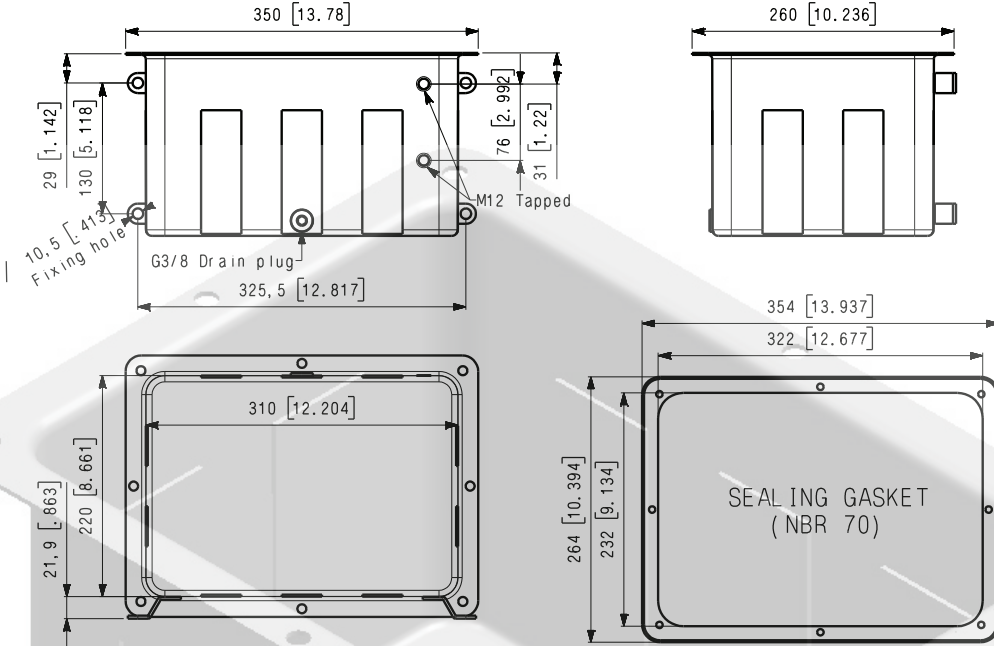

Lid 12 Litre (3,2 Gallon)

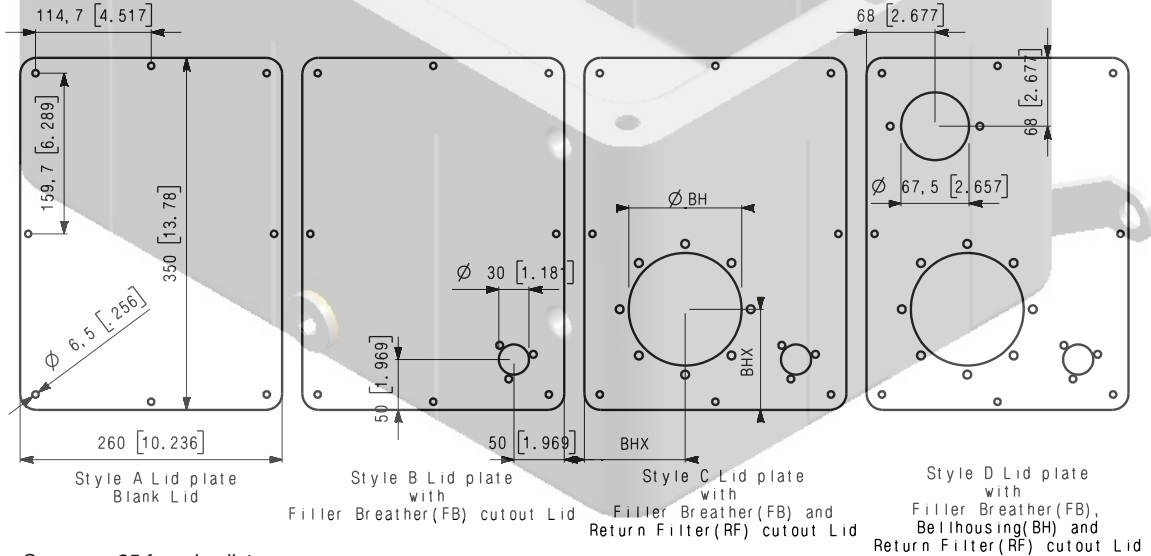

See page 25 for price list

FLOWFIT reserves the right to change specifications and information without notice.



Steel Tanks for Hydraulic Power Units 25 Litre Dimensional Data

Weldless Steel Tank 25 Litre (6,6 Gallon)

mm [in]

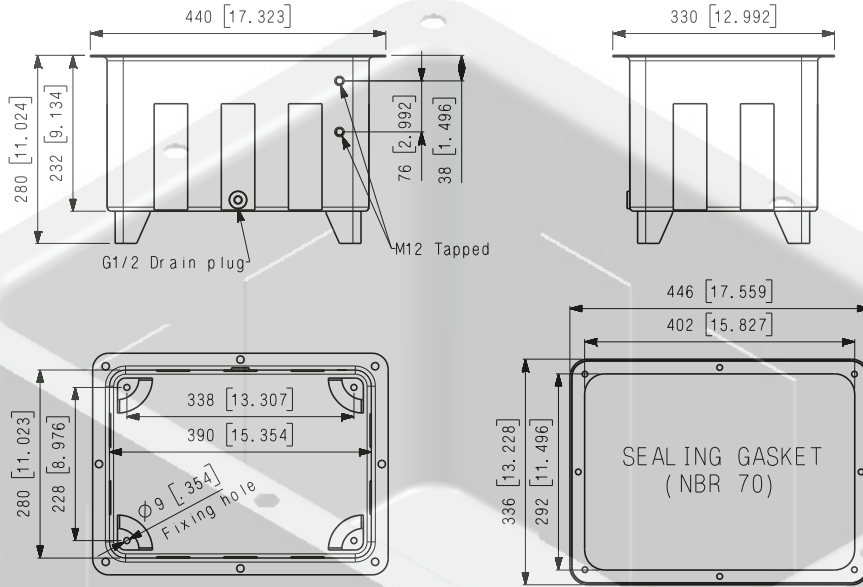

Lid 25 Litre (6,6 Gallon)

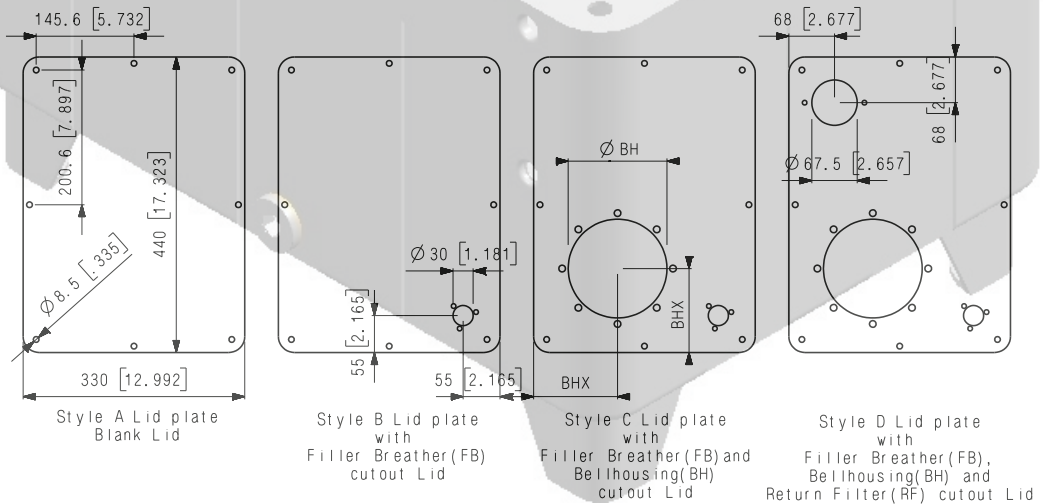

See page 25 for price list

FLOWFIT reserves the right to change specifications and information without notice.



Steel Tanks for Hydraulic Power Units 40 Litre Dimensional Data

Weldless Steel Tank 40 Litre (10,6 Gallon)

mm [in]

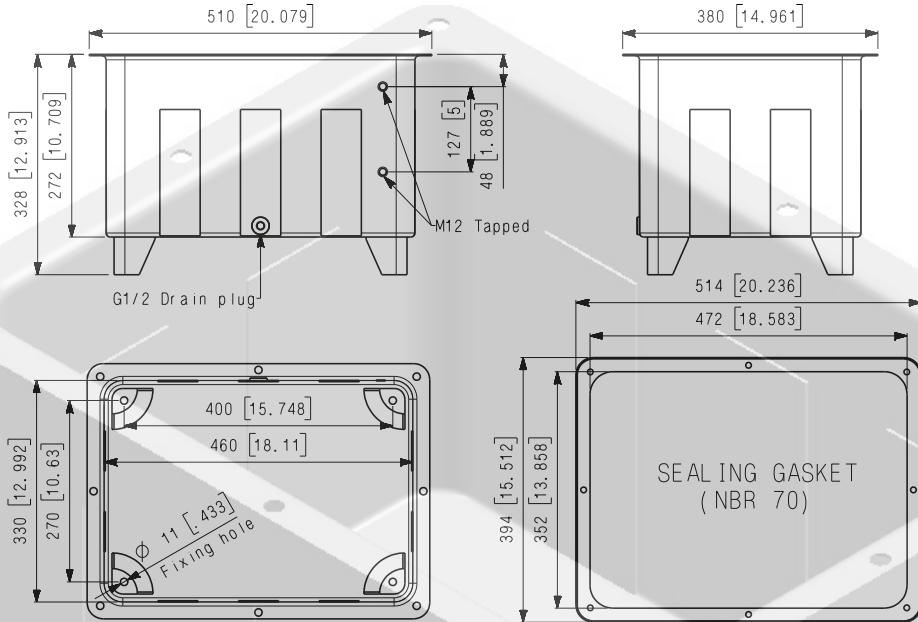

Lid 40 Litre (10,6 Gallon)

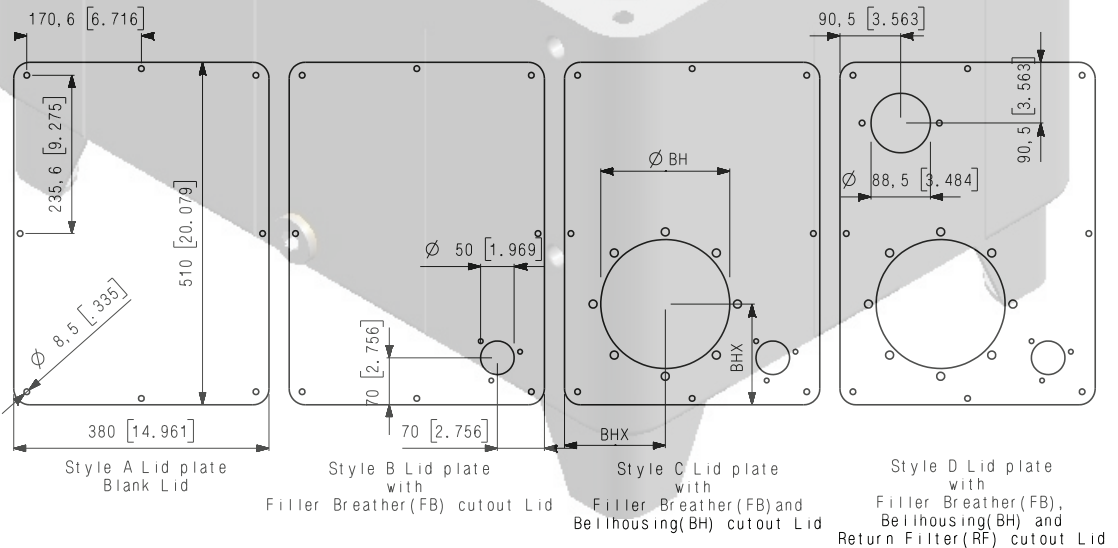

See page 25 for price list

FLOWFIT reserves the right to change specifications and information without notice.



Steel Tanks for Hydraulic Power Units 70 Litre Type A Dimensional Data

Weldless Steel Tank 70 Litre Type A (18,5 Gallon)

mm [in]

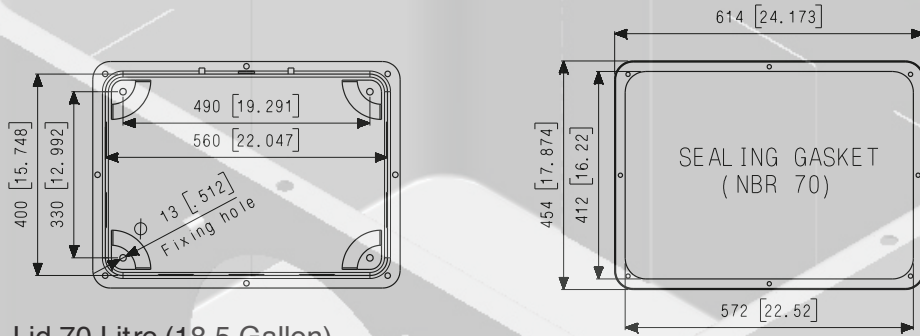
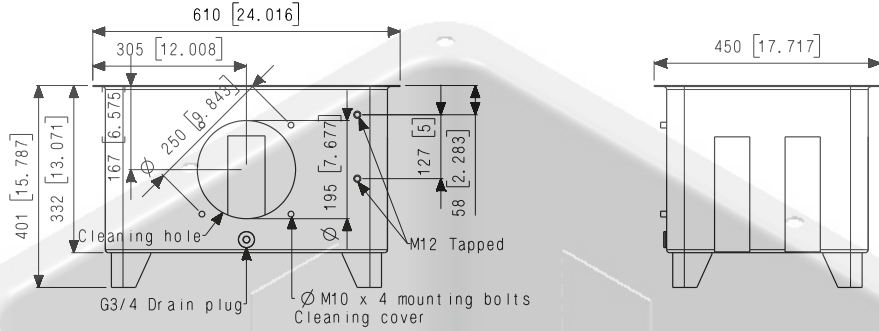

Lid 70 Litre (18,5 Gallon)

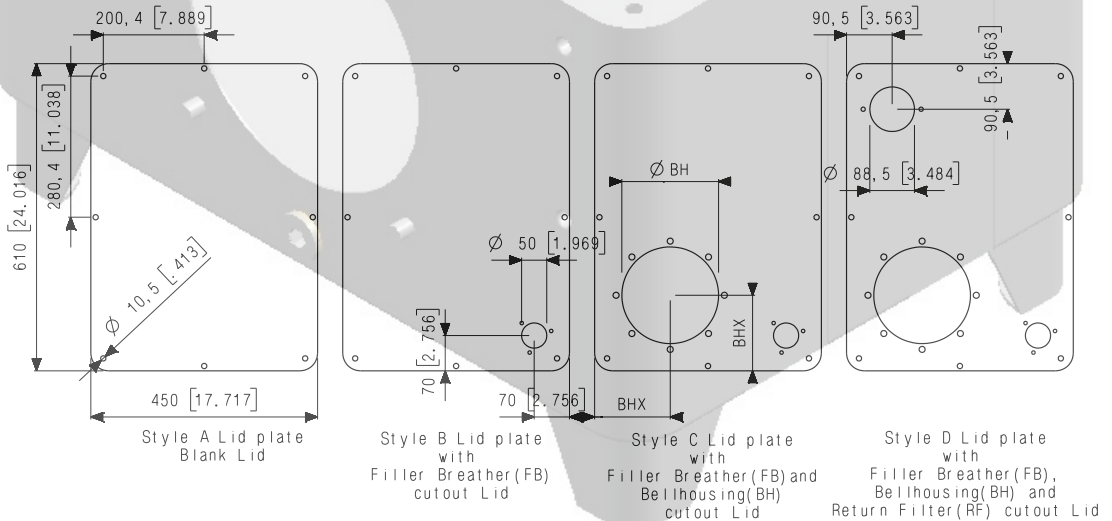

See page 26 for price list

FLOWFIT reserves the right to change specifications and information without notice.



Steel Tanks for Hydraulic Power Units 70 Litre Type B Dimensional Data

Weldless Steel Tank 70 Litre Type B (18,5 Gallon)

mm [in]

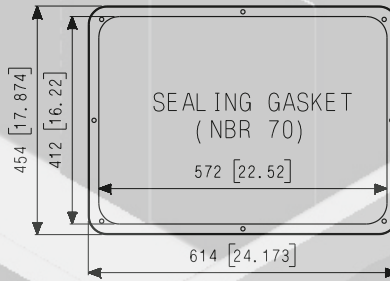
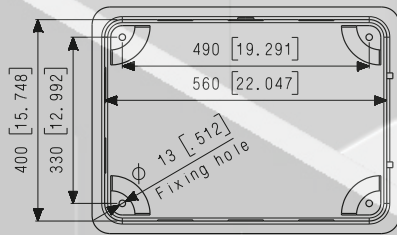
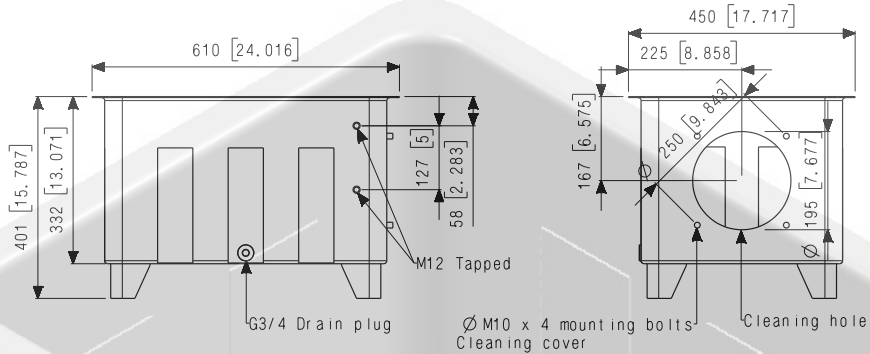

Lid 70 Litre (18,5 Gallon)

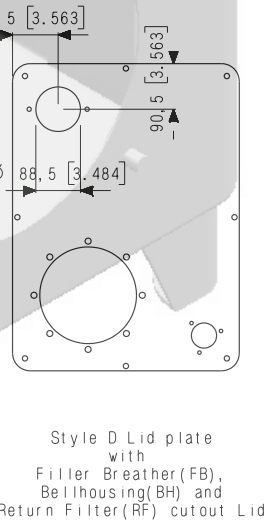
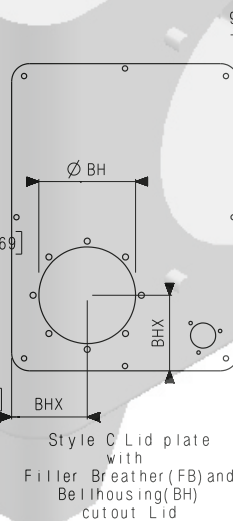
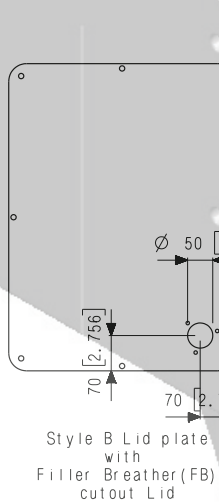
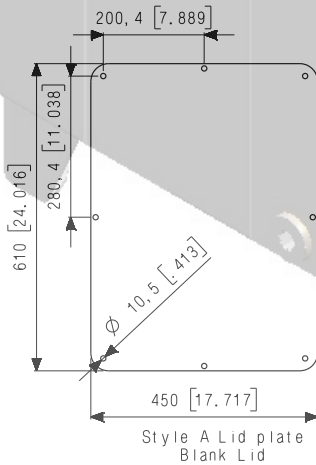

See page 26 for price list

FLOWFIT reserves the right to change specifications and information without notice.



Steel Tanks for Hydraulic Power Units 70 Litre Type C Dimensional Data

Weldless Steel Tank 70 Litre Type C (18,5 Gallon)

mm [in]

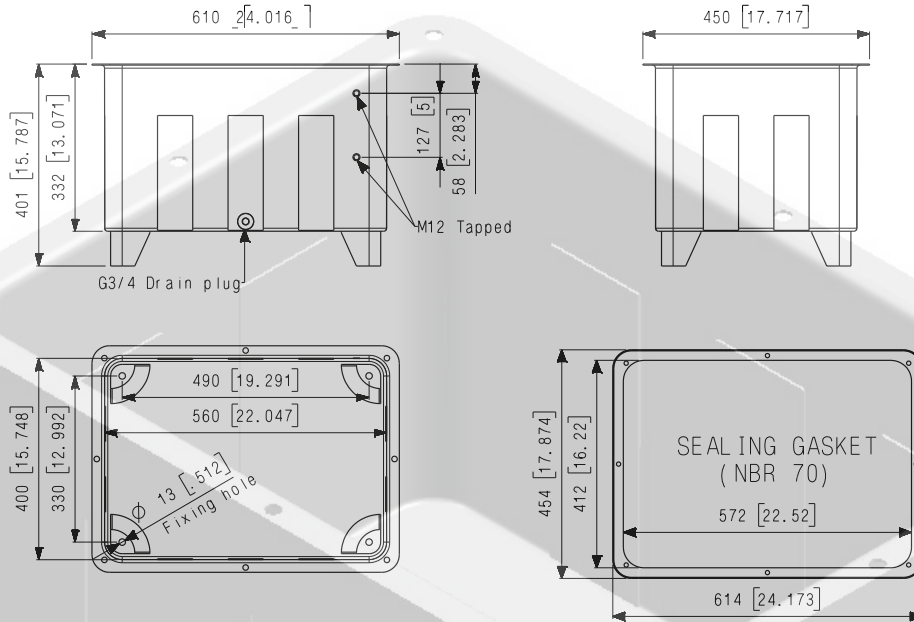

Lid 70 Litre (18,5 Gallon)

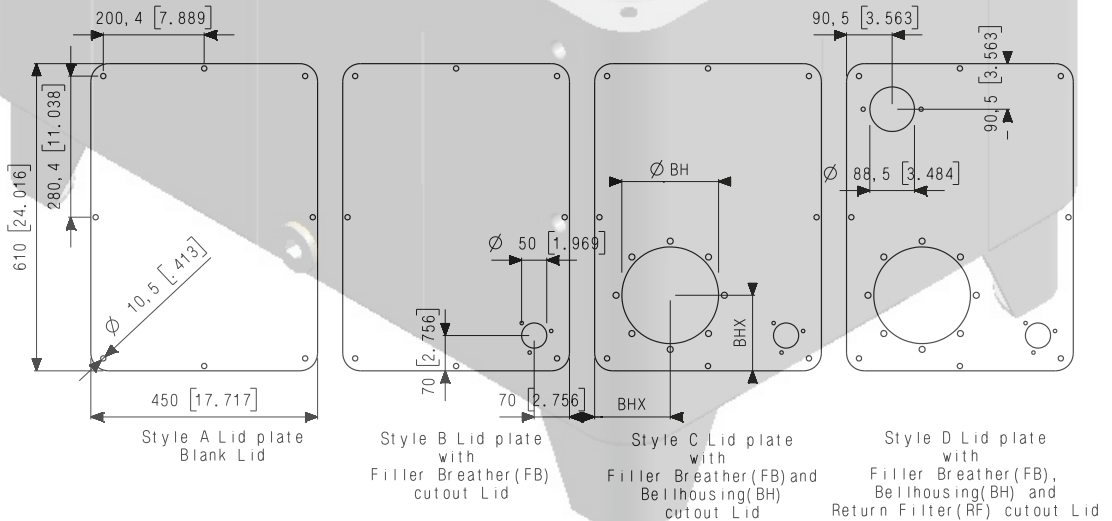

See page 26 for price list

FLOWFIT reserves the right to change specifications and information without notice.



Steel Tanks for Hydraulic Power Units 100 Litre Type A Dimensional Data

Weldless Steel Tank 100 Litre Type A (26,4 Gallon)

mm [in]

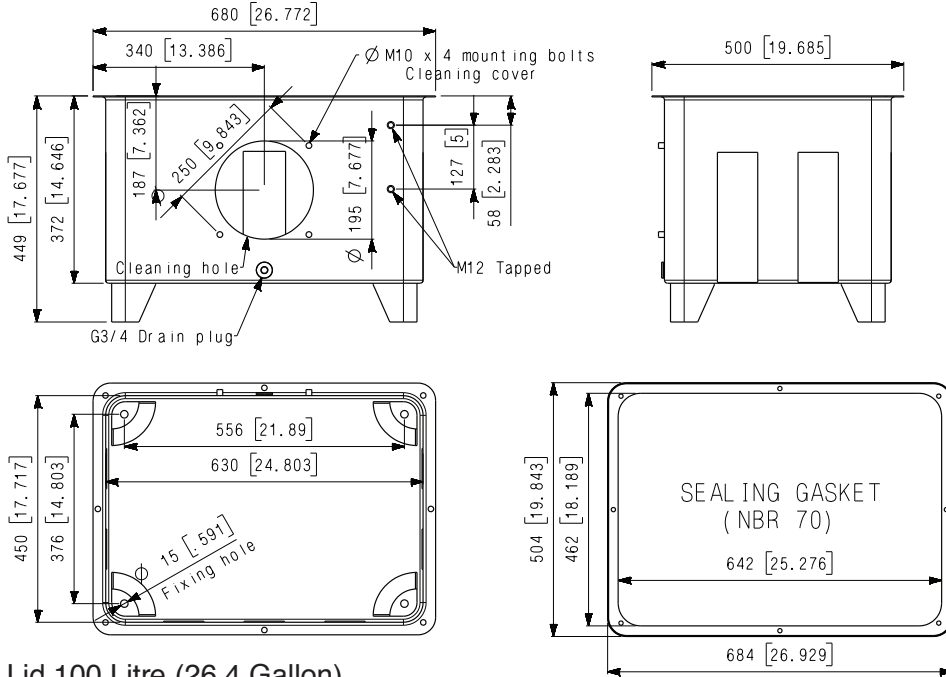

Lid 100 Litre (26,4 Gallon)

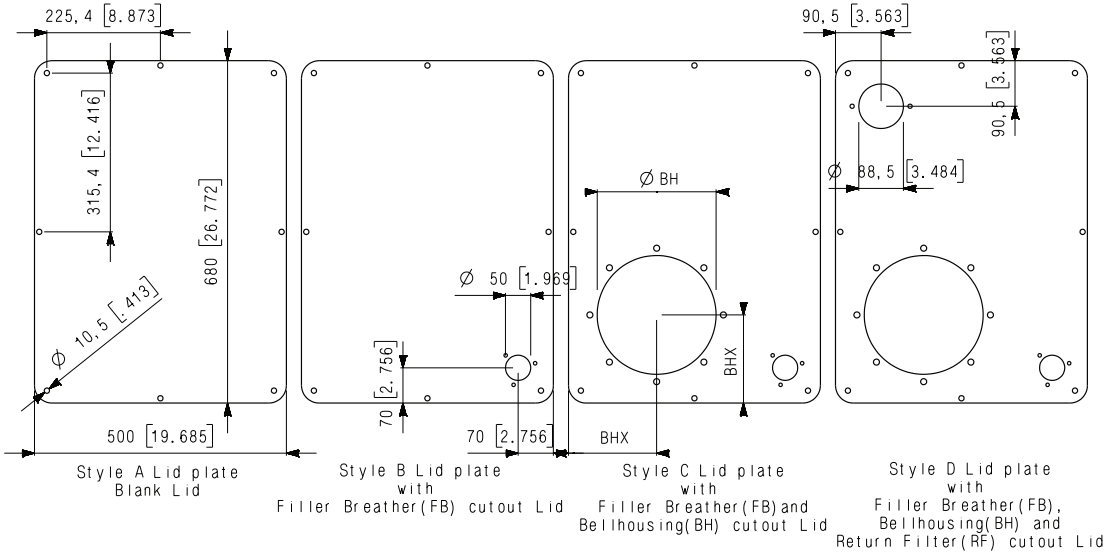

See page 27 for price list

FLOWFIT reserves the right to change specifications and information without notice.



Steel Tanks for Hydraulic Power Units 100 Litre Type B Dimensional Data

Weldless Steel Tank 100 Litre Type B (26,4 Gallon)

mm [in]

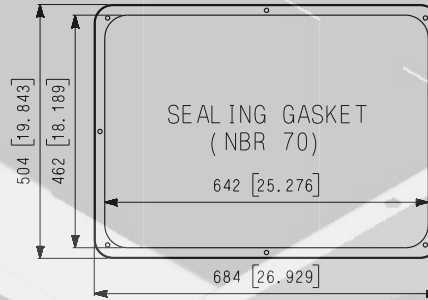
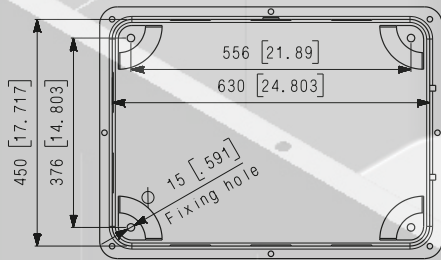
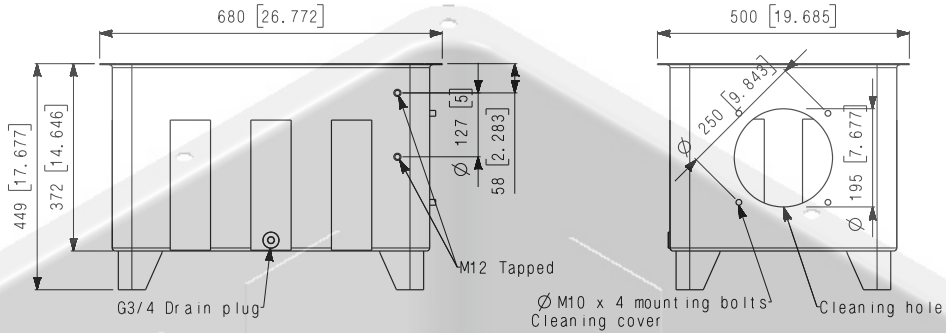

Lid 100 Litre (26,4 Gallon)

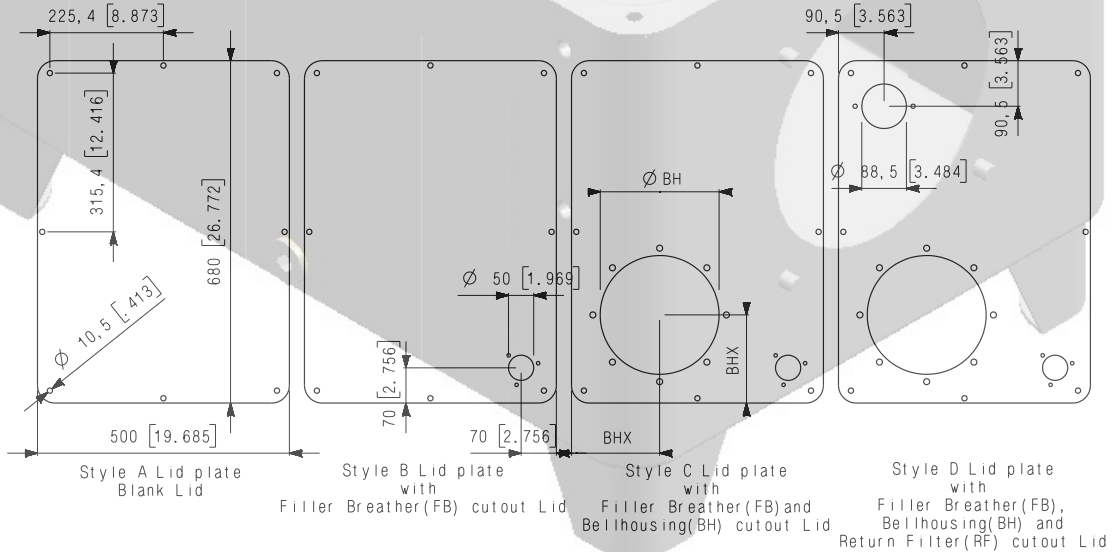

See page 27 for price list

FLOWFIT reserves the right to change specifications and information without notice.



Steel Tanks for Hydraulic Power Units 100 Litre Type C Dimensional Data

Weldless Steel Tank 100 Litre Type C (26,4 Gallon)

mm [in]

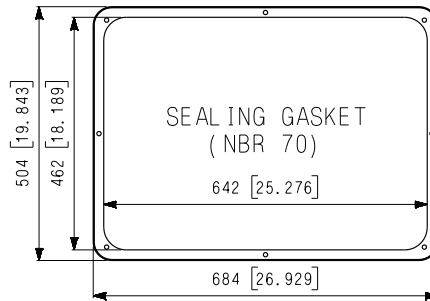
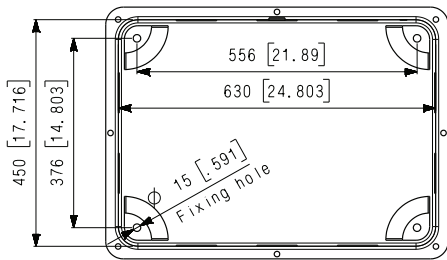
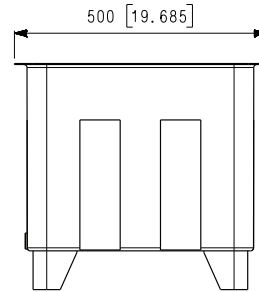
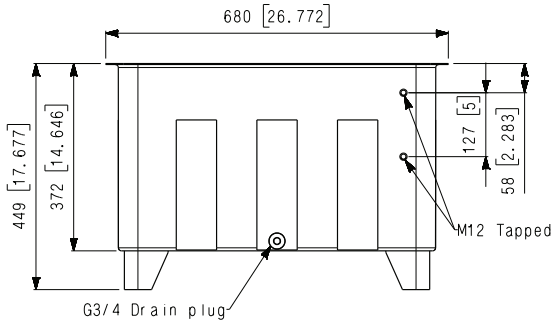

Lid 100 Litre (26,4 Gallon)

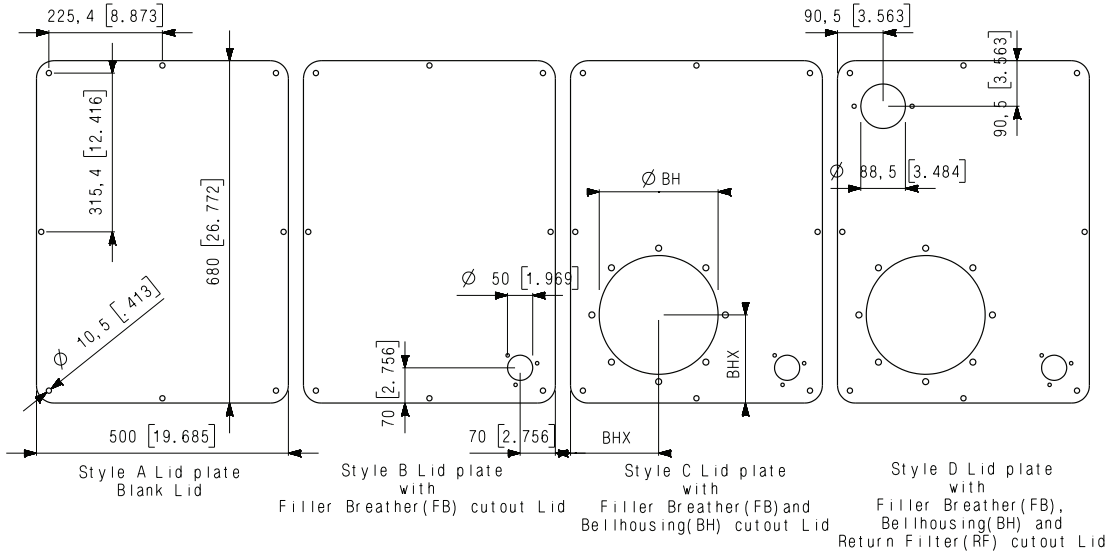

See page 27 for price list

FLOWFIT reserves the right to change specifications and information without notice.



Steel Tanks for Hydraulic Power Units 160 Litre Type A Dimensional Data

Weldless Steel Tank 160 Litre Type A (42,3 Gallon)

mm [in]

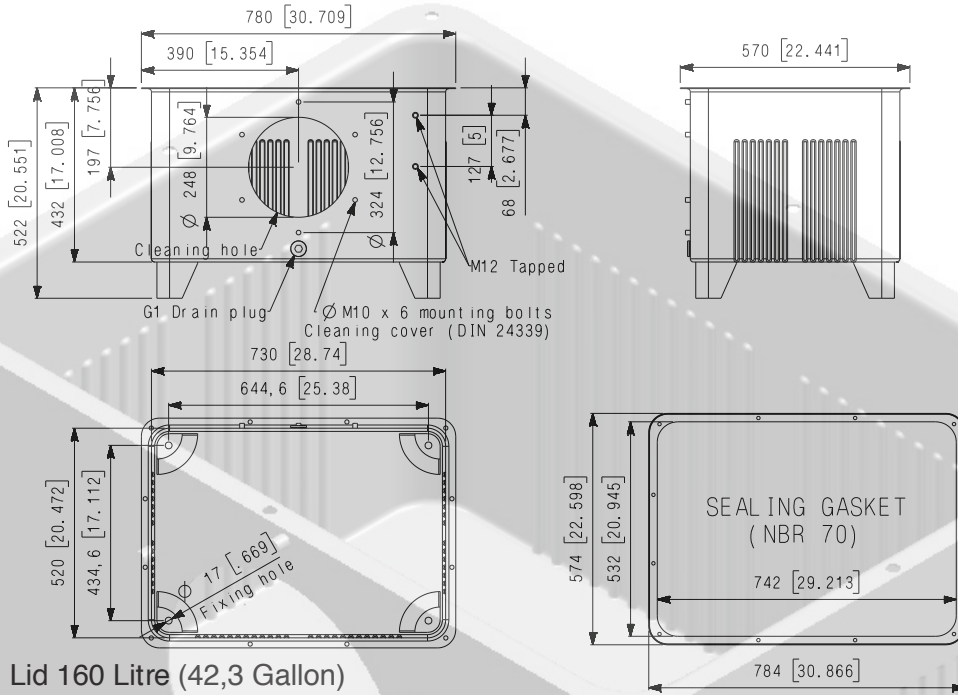

Lid 160 Litre (42,3 Gallon)

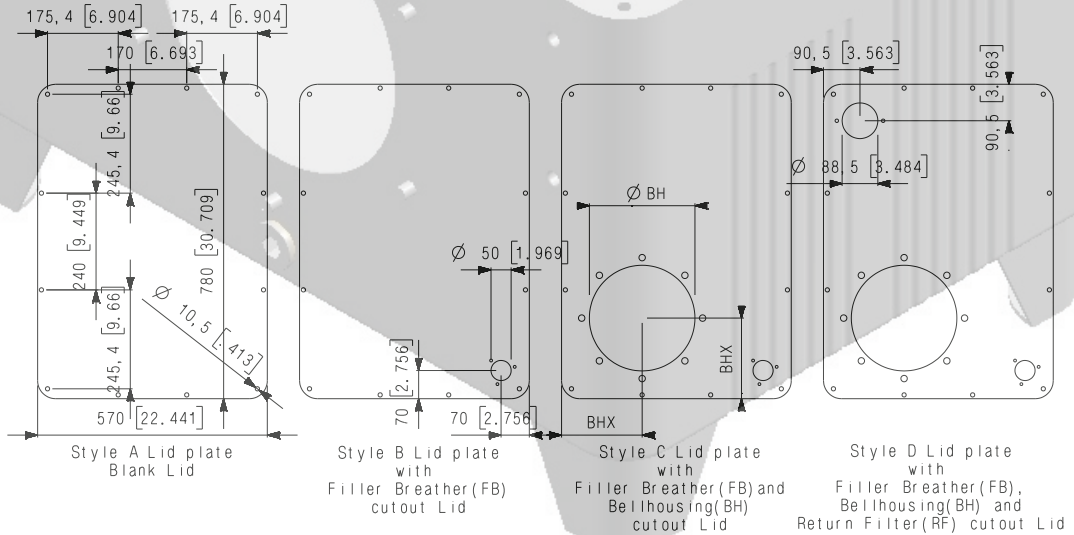

See page 27 for price list

FLOWFIT reserves the right to change specifications and information without notice.



Steel Tanks for Hydraulic Power Units 160 Litre Type B Dimensional Data

Weldless Steel Tank 160 Litre Type B (42,3 Gallon)

mm [in]

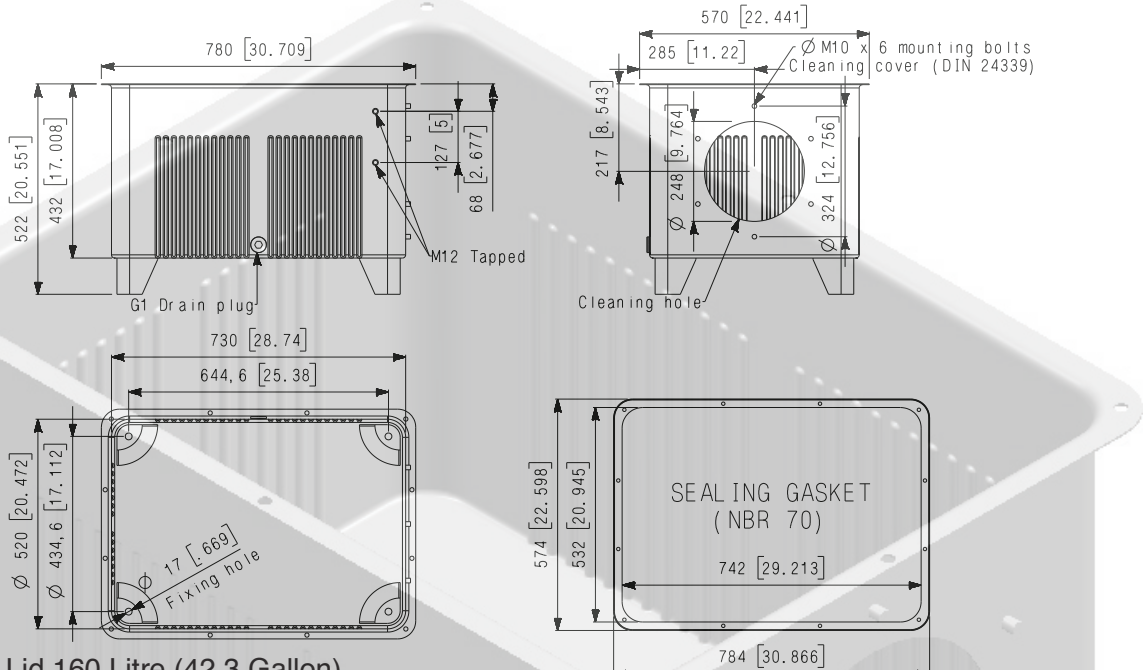

Lid 160 Litre (42,3 Gallon)

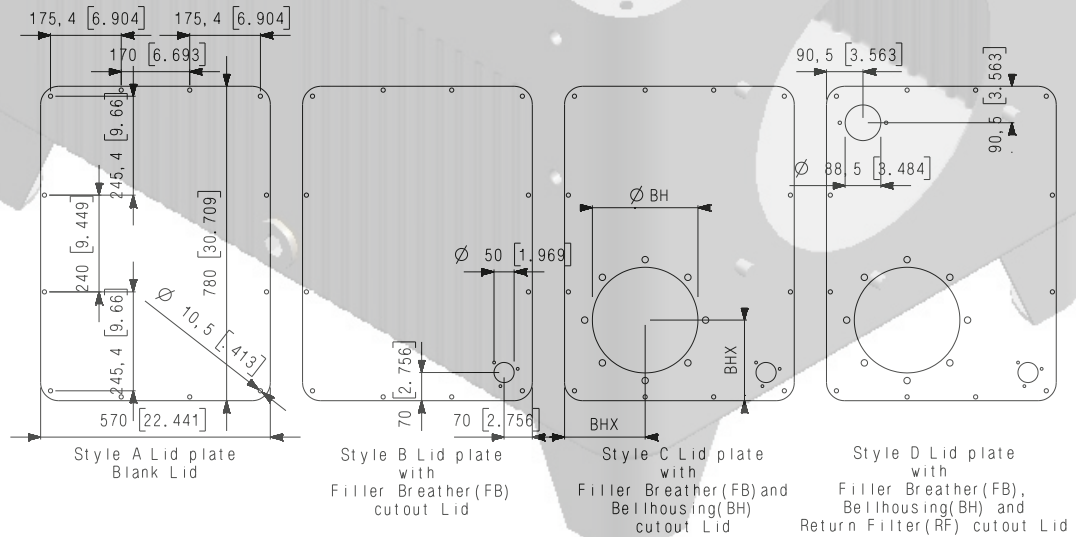

See page 27 for price list

FLOWFIT reserves the right to change specifications and information without notice.



Steel Tanks for Hydraulic Power Units 160 Litre Type C Dimensional Data

Weldless Steel Tank 160 Litre Type C (42,3 Gallon)

mm [in]

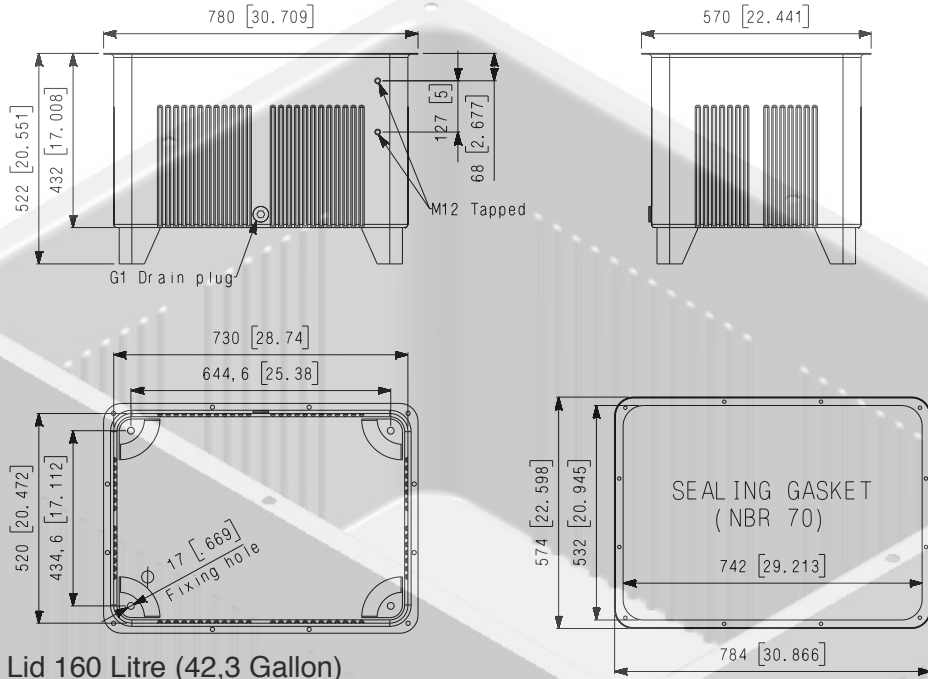

Lid 160 Litre (42,3 Gallon)

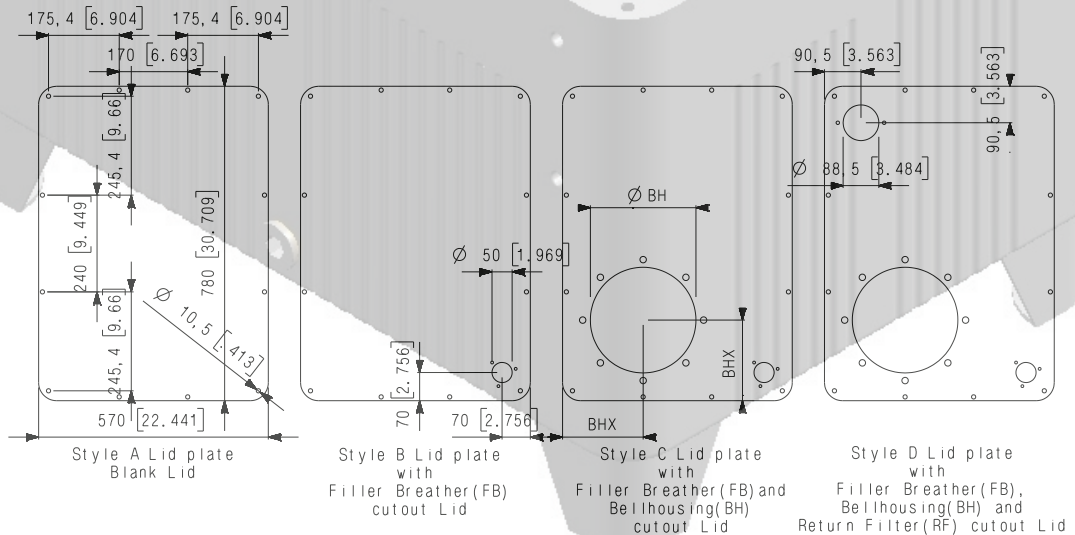

See page 27 for price list

FLOWFIT reserves the right to change specifications and information without notice.



Steel Tanks for Hydraulic Power Units 250 Litre Type A Dimensional Data

Weldless Steel Tank 250 Litre Type A (66,0 Gallon)

mm [in]

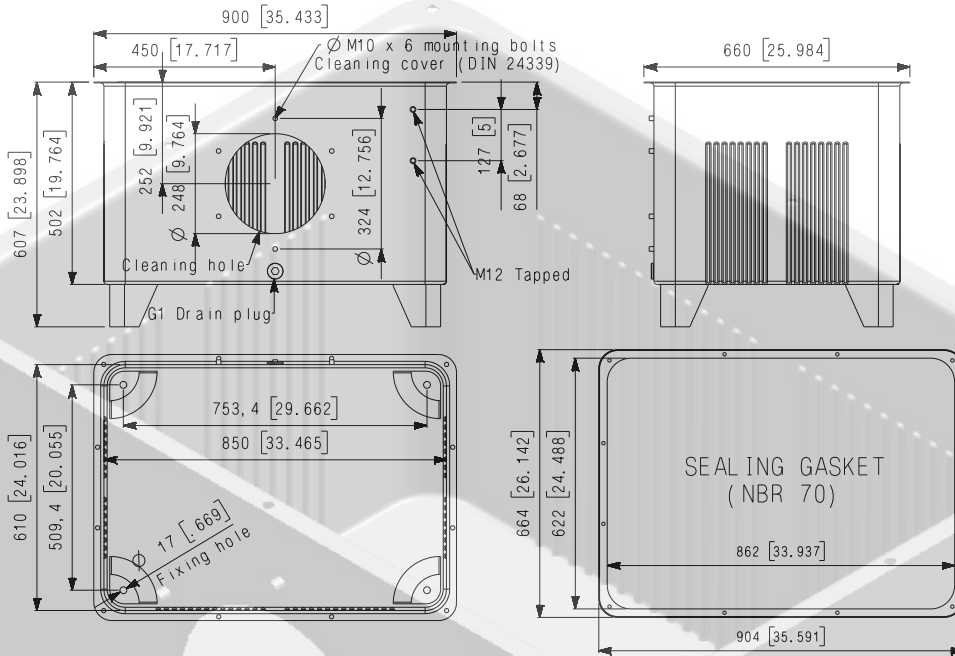

Lid 250 Litre (66,0 Gallon)

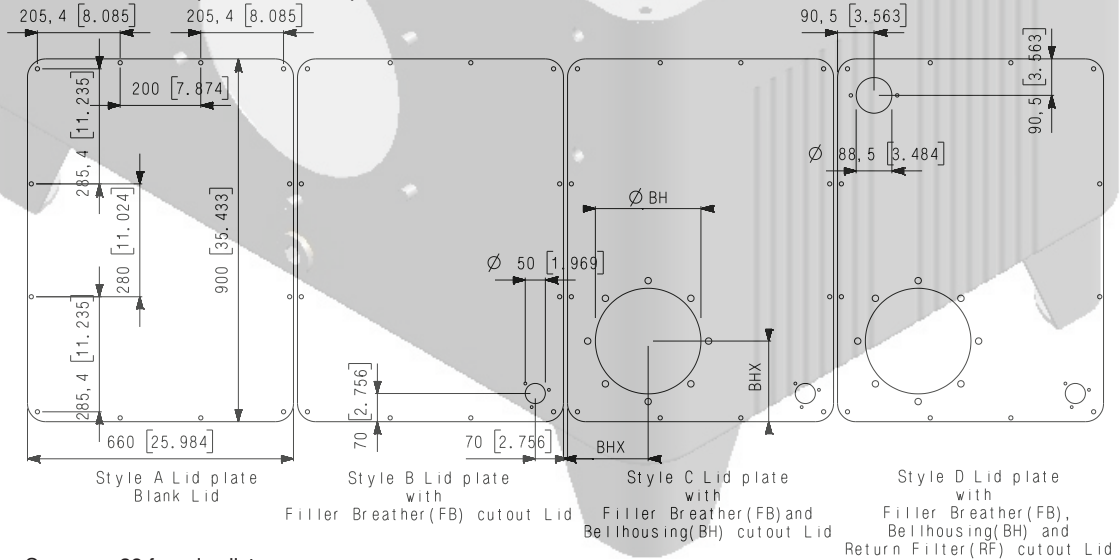

See page 28 for price list

FLOWFIT reserves the right to change specifications and information without notice.



Steel Tanks for Hydraulic Power Units 250 Litre Type B Dimensional Data

Weldless Steel Tank 250 Litre Type B (66,0 Gallon)

mm [in]

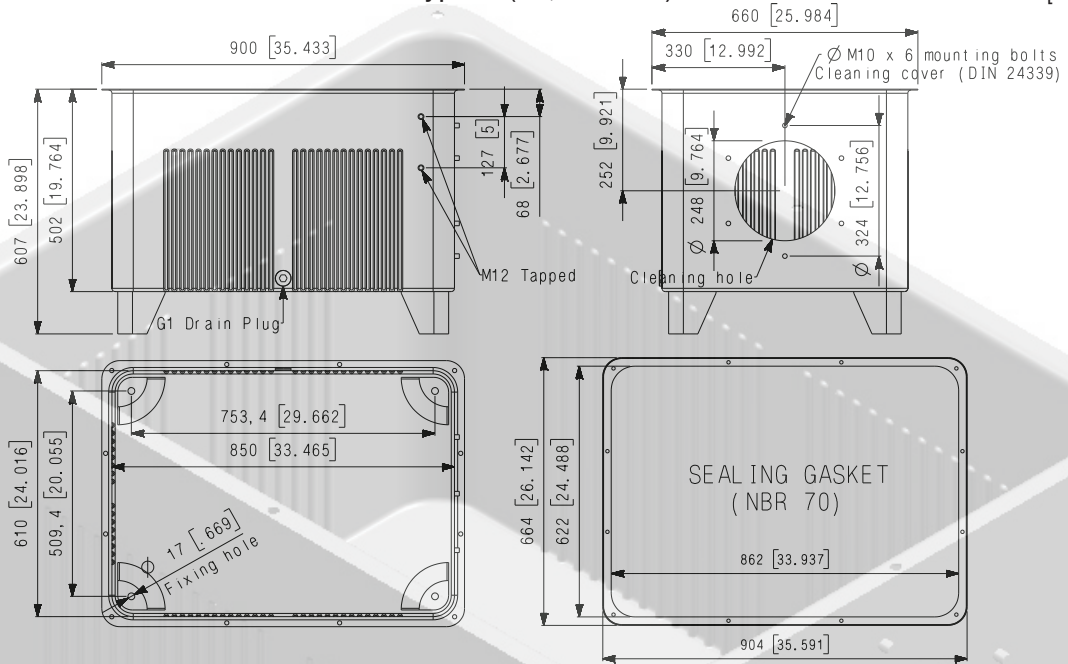

Lid 250 Litre (66,0 Gallon)

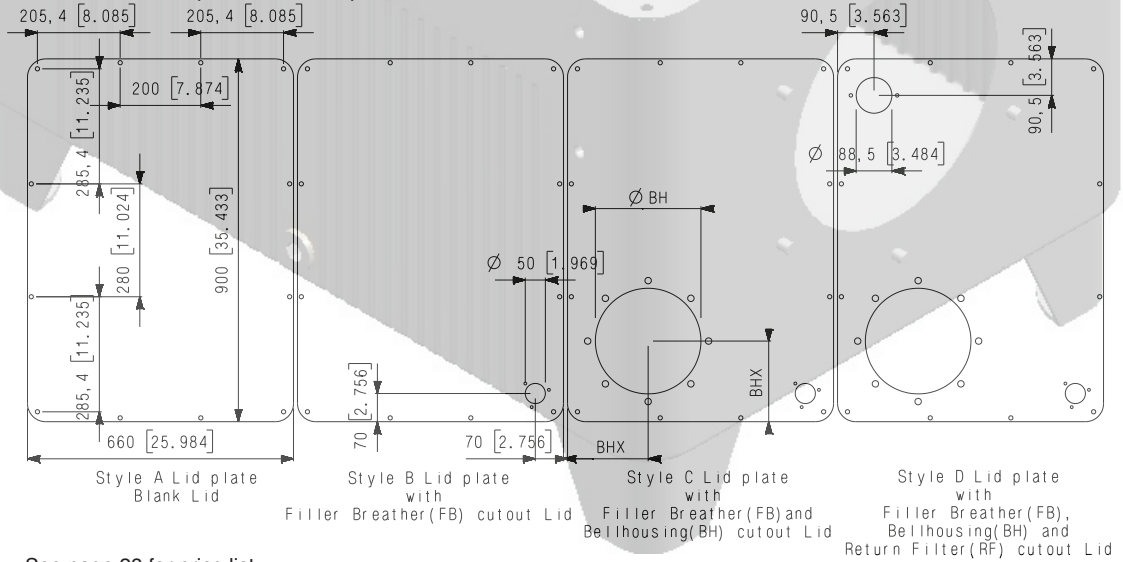

See page 28 for price list

FLOWFIT reserves the right to change specifications and information without notice.



Steel Tanks for Hydraulic Power Units 250 Litre Type C Dimensional Data

Weldless Steel Tank 250 Litre Type C (66,0 Gallon)

mm [in]

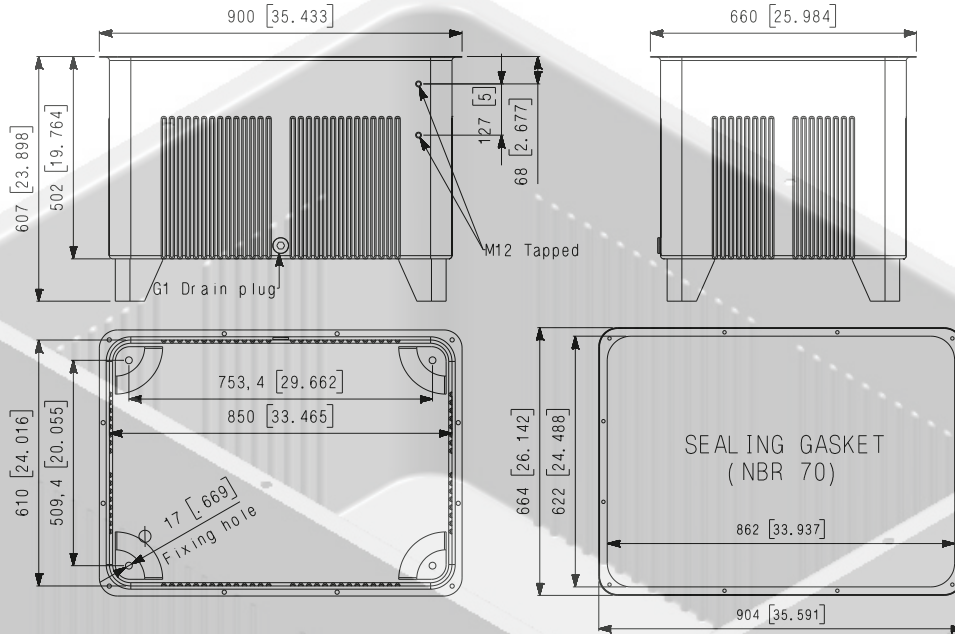

Lid 250 Litre (66,0 Gallon)

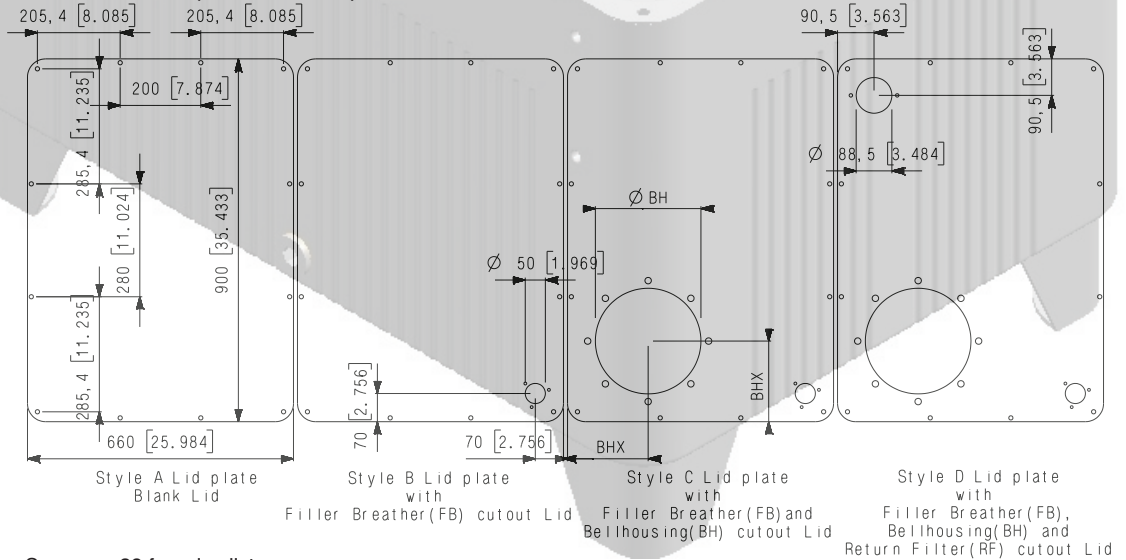

See page 28 for price list

FLOWFIT reserves the right to change specifications and information without notice.

Steel Tanks for Hydraulic Power Units Weights Chart

Weights Chart for Tanks, Lids and Sealing Gasket

CAPACITY (LT.)	6		12		25		40		70		100		160		250	
Type	A	B	A	B	-		-		A-B	C	A-B	C	A-B	C	A-B	C
TANK BODY	2,88 kg	2,73 kg	4,20 kg	3,96 kg	6,72 kg	9,20 kg	9,20 kg	13,19 kg	13,19 kg	13,59 kg	16,66 kg	17,06 kg	22,86 kg	23,74 kg	31,70 kg	32,68 kg
SEALING GASKET	0,10 kg		0,12 kg		0,20 kg	0,22 kg	0,22 kg		0,26 kg		0,29 kg		0,34 kg		0,40 kg	
LID THICKNESS																
Style A	3mm		3mm		3mm		3mm		4mm		4mm		5mm		5mm	
BLANK LID	1,48 kg		2,12 kg		3,39 kg	4,53 kg	4,53 kg		8,54 kg		10,59 kg		17,30 kg		23,15 kg	
Style B	3mm		3mm		3mm		3mm		4mm		4mm		5mm		5mm	
FB	1,47 kg		2,10 kg		3,37 kg	4,48 kg	4,48 kg		8,48 kg		10,53 kg		17,22 kg		23,07 kg	
FB+BH Ø 140	1,28 kg		1,92 kg		-	-	-	-	-	-	-	-	-	-	-	-
FB+BH Ø 160	1,22 kg		1,86 kg		3,13 kg											
FB+BH Ø 200	1,05 kg		1,69 kg		2,96 kg	4,07 kg	4,07 kg		7,92 kg		9,98 kg					
FB+BH Ø 250	-		-		2,67 kg	3,78 kg	3,78 kg		7,54 kg		9,59 kg		16,04 kg		21,89 kg	
FB+BH Ø 300	-		-		-	3,43 kg			7,08 kg		9,13 kg		15,47 kg		21,32 kg	
FB+BH Ø 350	-		-		-	-			6,74 kg		8,79 kg		15,04 kg		20,89 kg	
FB+BH Ø 400	-		-		-	-			-		-		-		20,19 kg	
FB+BH Ø 450	-		-		-	-			-		-		-		19,19 kg	
FB+BH Ø 140 +RF	1,20 kg		1,84 kg		-	-			-		-		-		-	
FB+BH Ø 160 +RF	1,14 kg		1,78 kg		3,05 kg											
FB+BH Ø 200 +RF	-		1,61 kg		2,88 kg	3,92 kg	3,92 kg		7,72 kg		9,78 kg					
FB+BH Ø 250 +RF	-		-		2,59 kg	3,63 kg	3,63 kg		7,34 kg		9,39 kg		15,79 kg		21,64 kg	
FB+BH Ø 300 +RF	-		-		-	3,28 kg			6,88 kg		8,93 kg		15,22 kg		21,07 kg	
FB+BH Ø 350 +RF	-		-		-	-			6,54 kg		8,59 kg		14,79 kg		20,64 kg	
FB+BH Ø 400 +RF	-		-		-	-			-		-		-		19,94 kg	
FB+BH Ø 450 +RF	-		-		-	-			-		-		-		18,94 kg	

FB - Filler Breather , BH - Bellhousing , RF - Return Filter

Steel Tanks for Hydraulic Power Units Lid Layout Dimensions for Bellhousing

Chart for Bellhousing

CAPACITY (LT.)	Ø BH	6 BHX	12 BHX	25 BHX	40 BHX	70 BHX	100 BHX	160 BHX	250 BHX
Bellhousing									
Ø 140	Ø 97	90	90	-	-	-	-	-	-
Ø 160	Ø 112	100	100	105	-	-	-	-	-
Ø 200	Ø 147	110	120	125	125	125	125	-	-
Ø 250	Ø 192	-	-	150	150	150	150	150	150
Ø 300	Ø 236	-	-	-	175	175	175	175	175
Ø 350	Ø 262	-	-	-	-	188	200	200	200
Ø 400	Ø 302	-	-	-	-	-	-	-	225
Ø 450	Ø 352	-	-	-	-	-	-	-	250

Value Added Service Available

Flowfit can laser cut Different Shapes in your Lids and tanks for

- Supply Lines
- Return Lines
- Drain Lines
- Pump / Motor mount holes for vertical installations
- Filler / Breather holes
- Level Gauges (on Tanks) with M12 tapped
- Mounting holes