

# ELL-SERIES



ELL-602, ELL-1002

## ELL-SERIES PANCAKE LOCKNUT CYLINDERS

### ► Features

- ◆ Extremely low height for use in confined spaces.
- ◆ Safety lock nut for mechanical load holding.
- ◆ Tilting saddle.
- ◆ Complies with ASME B30.1. High strength steel for durability and increased safety.
- ◆ Overflow port functions as a stroke limiter.
- ◆ High flow EAB-201 quick coupler.
- ◆ Environmentally friendly painting process provides a durable corrosion resistant finish.

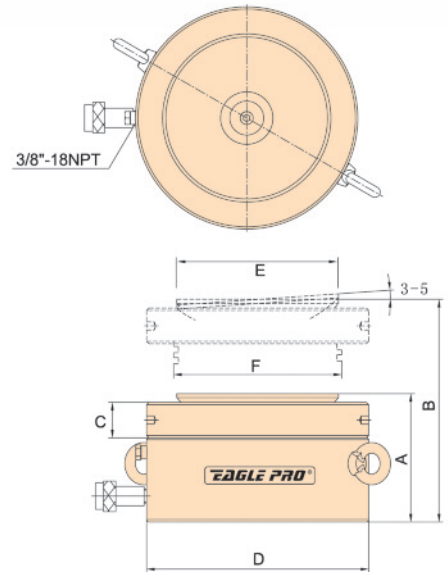

Cylinder Capacity @700bar	Stroke	Model	Cylinder Effective Area	Oil Capacity	Collapsed Height	Extended Height	Lock Nut height	Outside Diameter	Saddle diam.	Piston Rod Diameter	Weight
					A	B					
ton	in		in <sup>2</sup>	in <sup>3</sup>	in	in	in	in	in	mm	lbs
60	1.97	ELL-602	13.42	26.41	4.92	6.89	1.10	5.51	3.77	Tr 104 × 4	33
100	1.97	ELL-1002	22.17	43.62	5.39	7.36	1.22	6.89	4.95	Tr 134.5 × 6	57.2
160	1.77	ELL-1602	35.17	62.28	5.83	7.60	1.57	8.66	6.29	Tr 170 × 6	96.8
200	1.77	ELL-2002	43.93	77.78	6.10	7.87	1.69	9.65	7.07	Tr 190 × 6	125.4
260	1.77	ELL-2502	56.25	99.61	6.26	8.03	1.73	10.83	7.86	Tr 215 × 6	162.8
400	1.77	ELL-4002	85.45	151.34	7.01	8.78	2.17	13.78	9.83	Tr 265 × 6	294.8
520	1.77	ELL-5002	113.20	200.45	7.56	9.33	2.44	15.75	11.4	Tr 305 × 6	415.8