

FLOWFIT® TECHNICAL DATA SHEET

SERIES 70012 CAST IRON PTO GEARBOX PUMP GROUP 3 · 37KW **FLOWFIT**

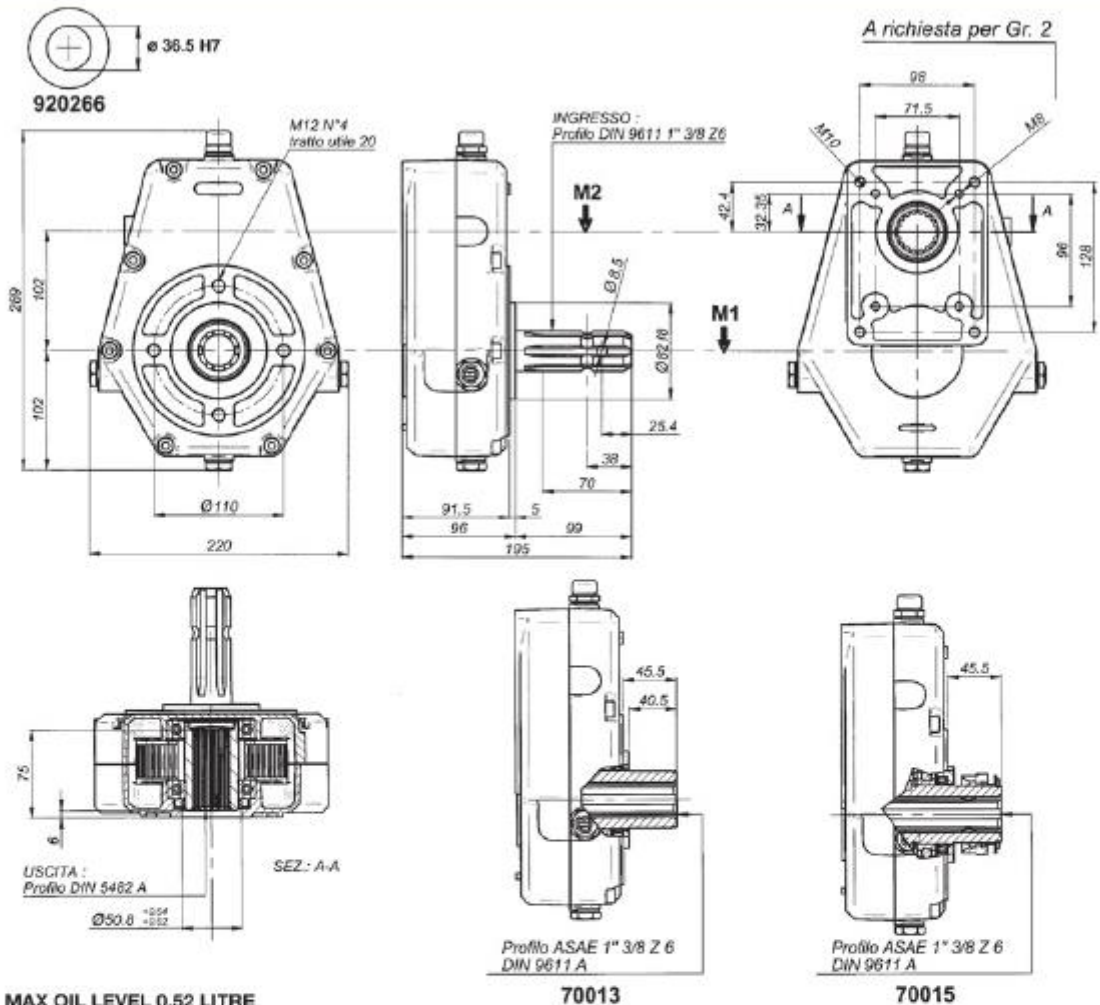

MAX OIL LEVEL 0.52 LITRE

M1 MAXIMUM CONTINUOUS TORQUE OF THE PTO GEARBOX (Input side daNm)	M2 MAXIMUM TORQUE OF THE PTO GEARBOX (Output side daNm)	N1 TRACTOR OUTPUT SPEED RPM	N2 FINAL OUTPUT SPEED OF PUMP/GEARBOX ASSEMBLY RPM	I RATIO OF SPEED INCREASE	KW MAX TRANSMITTABLE POWER	WEIGHT KG
66	66	540	540	1	37	14.5
66	44	540	810	1.5	37	14.5
66	33	540	1080	2	37	14.5
66	26.4	540	1408	2.5	37	14.5
66	22	540	1620	3	37	14.5
66	18	540	1836	3.5	35	14.5
66	16.6	540	2057	3.8	35	14.5

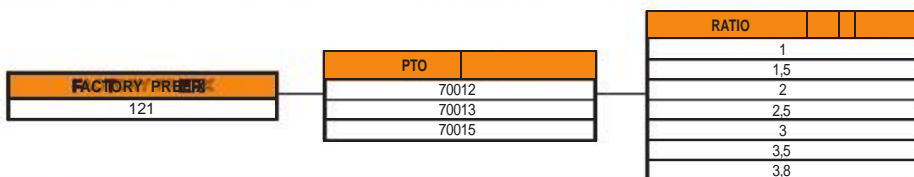

PART NO.	DESCRIPTION OF PTO GEARBOX
121-70012	PTO GEARBOX ANY RATIO MALE SHAFT 1 3/8" 6 SPLINE
121-70013	PTO GEARBOX ANY RATIO FEMALE SHAFT 1 3/8" 6 SPLINE
121-70015	PTO GEARBOX ANY RATIO FEMALE SHAFT 1 3/8" 6 SPLINE C/W QRC

If the part number needed is not listed please ask the Flowfit Sales Team

PUMPS GROUP 3 • PERFORMANCE



Flow - Speed chart

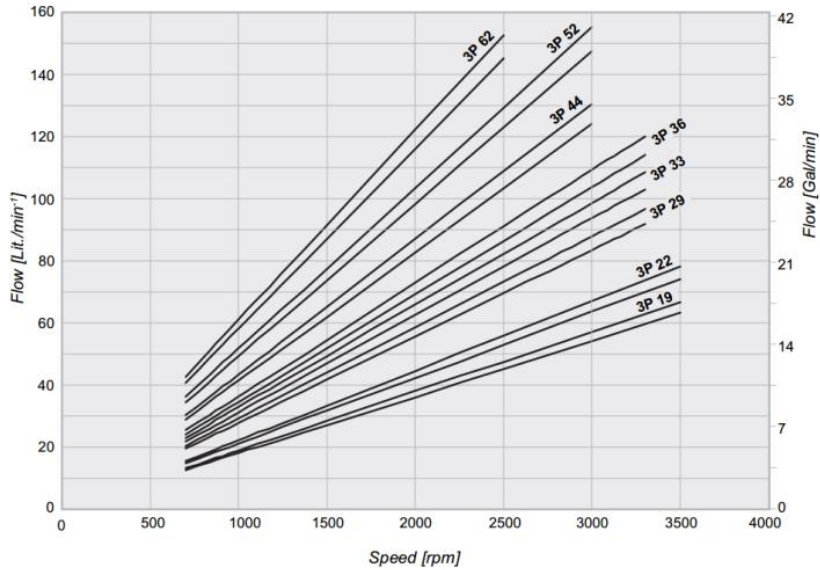

Pumps Group 3 Power and Speed Diagrams

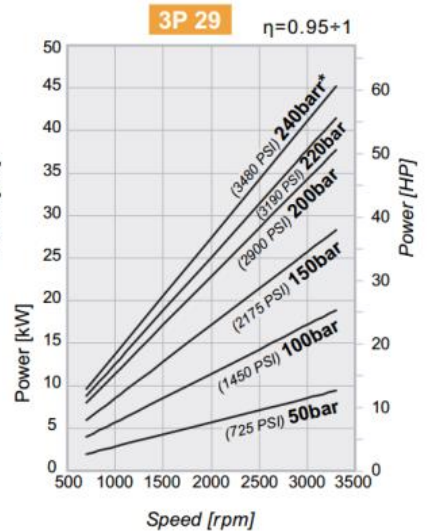
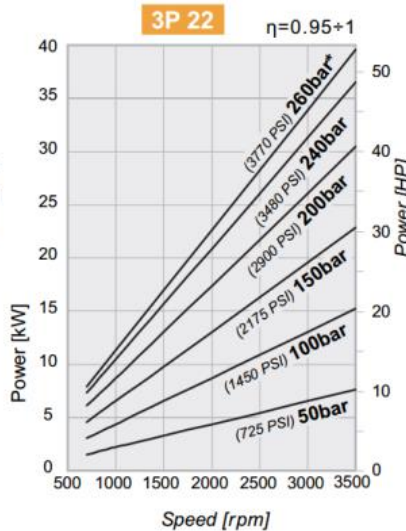
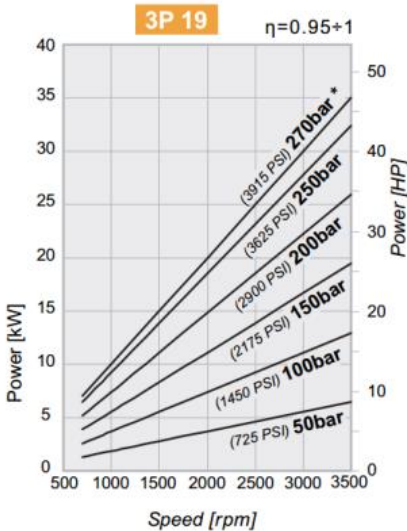

* Only for cast iron pumps

Pumps Group 3 Power and Speed Diagrams

