

Male stud coupling  
 Gerade-Einschraubverschraubung  
 Union simple mâle

**P-GEV ..... NPT**

Stud thread: NPT (ANSI/ASME B1.20.1-1983)

Einschraub-  
 gewinde: NPT (ANSI/ASME B1.20.1-1983)

Filetage mâle: NPT (ANSI/ASME B1.20.1-1983)

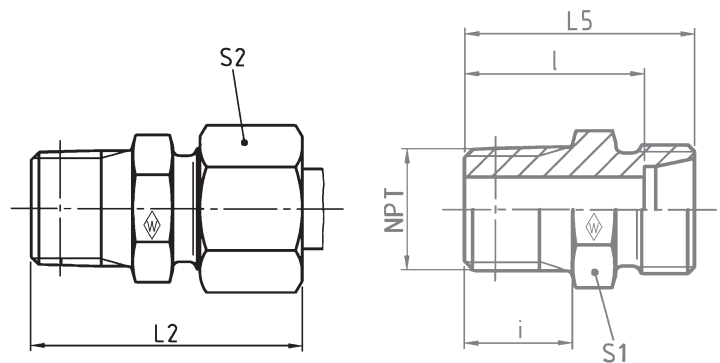

Series	bar	Tube OD		Type	Reference	kg per						
Reihe	PN	Rohr-AD		Typ	Best.-Nr.	100 pcs.						
Série	(psi)	Tube Ø ext.	NPT	Désignation	Réf.	100 St.	L <sub>2</sub>	L <sub>5</sub>	l	i	S <sub>1</sub>	S <sub>2</sub>
						kg par						
						100 p.						
LL	100 (1450)	4	1/8 NPT	<b>S-GEV 4 LL/1/8 NPT</b>	<b>WAL038241</b>	1,5	28	22	18	10	11	10
		6	1/8 NPT	<b>S-GEV 6 LL/1/8 NPT</b>	<b>WAL038243</b>	1,5	28	22	16,5	10	11	12
		8	1/8 NPT	<b>S-GEV 8 LL/1/8 NPT</b>	<b>WAL038244</b>	2,0	30	24	18,5	10	12	14
L	315 (4569)	6	1/8 NPT	<b>P-GEV 6 L/1/8 NPT</b>	<b>WAL373026</b>	2,6	32	24	17	10	12	14
		6	1/4 NPT	<b>P-GEV 6 L/1/4 NPT</b>	<b>WAL373027</b>	3,9	38	30	23	15	17	14
		8	1/4 NPT	<b>P-GEV 8 L/1/4 NPT</b>	<b>WAL373028</b>	4,0	38	30	23	15	17	17
		10	1/4 NPT	<b>P-GEV 10 L/1/4 NPT</b>	<b>WAL373029</b>	4,8	39	31	24	15	17	19
		10	3/8 NPT	<b>P-GEV 10 L/3/8 NPT</b>	<b>WAL373030</b>	6,0	40	32	25	15	19	19
		12	1/4 NPT	<b>P-GEV 12 L/1/4 NPT</b>	<b>WAL373031</b>	6,0	40	32	25	15	19	22
		12	3/8 NPT	<b>P-GEV 12 L/3/8 NPT</b>	<b>WAL373032</b>	6,5	40	32	25	15	19	22
		12	1/2 NPT	<b>P-GEV 12 L/1/2 NPT</b>	<b>WAL373033</b>	8,5	45	37	30	20	24	22
		15	1/2 NPT	<b>P-GEV 15 L/1/2 NPT</b>	<b>WAL373034</b>	11,0	46	38	31	20	24	27
		18	1/2 NPT	<b>P-GEV 18 L/1/2 NPT</b>	<b>WAL373035</b>	13,5	48	39	31,5	20	27	32
	160 (2321)	22	3/4 NPT	<b>P-GEV 22 L/3/4 NPT</b>	<b>WAL373036</b>	19,0	50	41	33,5	20	32	36
		28	1 NPT	<b>P-GEV 28 L/1 NPT</b>	<b>WAL373037</b>	27,5	56	47	39,5	25	41	41
		35	1 1/4 NPT	<b>P-GEV 35 L/1 1/4 NPT</b>	<b>WAL373038</b>	40,5	62	51	40,5	26	46	50
		42	1 1/2 NPT	<b>P-GEV 42 L/1 1/2 NPT</b>	<b>WAL373039</b>	57,0	65	53	42	26	55	60
S	630 (9137)	6	1/4 NPT	<b>P-GEV 6 S/1/4 NPT</b>	<b>WAL373040</b>	5,0	43	35	28	15	17	17
		8	1/4 NPT	<b>P-GEV 8 S/1/4 NPT</b>	<b>WAL373041</b>	5,5	43	35	28	15	17	19
		10	1/4 NPT	<b>P-GEV 10 S/1/4 NPT</b>	<b>WAL373042</b>	8,5	44	35	27,5	15	19	22
		10	3/8 NPT	<b>P-GEV 10 S/3/8 NPT</b>	<b>WAL373043</b>	8,0	44	35	27,5	15	19	22
		12	1/4 NPT	<b>P-GEV 12 S/1/4 NPT</b>	<b>WAL373044</b>	9,5	46	37	29,5	15	22	24
		12	3/8 NPT	<b>P-GEV 12 S/3/8 NPT</b>	<b>WAL373045</b>	10,0	46	37	29,5	15	22	24
		12	1/2 NPT	<b>P-GEV 12 S/1/2 NPT</b>	<b>WAL373046</b>	12,5	51	42	34,5	20	22	24
		14	1/2 NPT	<b>P-GEV 14 S/1/2 NPT</b>	<b>WAL373047</b>	15,5	54	44	36	20	24	27
		16	1/2 NPT	<b>P-GEV 16 S/1/2 NPT</b>	<b>WAL373048</b>	16,0	54	44	35,5	20	27	30
		20	3/4 NPT	<b>P-GEV 20 S/3/4 NPT</b>	<b>WAL373049</b>	25,0	59	48	37,5	20	32	36
	400 (5801)	25	1 NPT	<b>P-GEV 25 S/1 NPT</b>	<b>WAL373050</b>	47,5	69	57	45	25	41	46
		30	1 1/4 NPT	<b>P-GEV 30 S/1 1/4 NPT</b>	<b>WAL373051</b>	62,0	73	60	46,5	26	46	50
		38	1 1/2 NPT	<b>P-GEV 38 S/1 1/2 NPT</b>	<b>WAL373052</b>	89,0	80	65	49	26	55	60

L<sub>2</sub> = approximate length with nut tightened  
 L<sub>2</sub> = Ungefährmaß bei angezogener Überwurfmutter  
 L<sub>2</sub> = longueur approximative, l'écrou étant bloqué

Taper port form NPT (ANSI/ASME B1.20.1-1983)  
 Kegelige Einschraublöcher NPT (ANSI/ASME B1.20.1-1983)  
 Trous taraudés coniques NPT (ANSI/ASME B1.20.1-1983)