

WEA SERIES (IE2)

THREE PHASE HIGH EFFICIENCY
TEFC ALUMINUM
INDUCTION MOTORS



WEA series three phase asynchronous motor is high efficiency motors with aluminum housing. It is WONDER-designed high efficiency motors with product features as compact size, less weight and outstanding appearance. Its efficiency indicators are in line with IE2.

Characteristics for all WONDER standard 3-Phase asynchronous motors

- Widely applied in general machinery and industries such as pumps & water treatment, road machinery, petroleum, chemical, metallurgy, cement and paper-milling.
- IP55 protection, Class F insulation, B Temperature rise, S1 duty,
- Rated voltage 400V, Rated frequency 50Hz.
- Operation conditions: ambient temperature:-20℃ ~40℃, altitude≤1000m.
- Y-connection for motors up to 3kW and Δ-connection for 4kW and above
- Cooling method is Ic411.

MOUNTING ARRANGEMENTS

Types	Basic type of construction	Derived types of construction				
WEA80-180	IM B3 IM 1001	IM V5 IM 1011	IM V6 IM 1031	IM B6 IM 1051	IM B7 IM 1061	IM B8 IM 1071
WEA80-180	IM B35 IM 2001	IM V15 IM 2011	IM V36 IM 2031	IM 2051	IM 2061	IM 2071
WEA80-180	IM B34 IM 2101	IM 2111	IM 2131	IM 2151	IM 2161	IM 2171
WEA80-180	IM B5 IM 3001	IM V1 IM 3011	IM V6 IM 3031			
WEA80-180	IM B14 IM 3601	IM V18 IM 3611	IM V19 IM 3631			

basic types of construction may be used in all derived types of construction
 (*)not-defined mounting by IEC 60034-7
 1) for the types of construction IM V6,IM B6,IM B8 inquiry is necessary.

WEA HIGH EFFICIENCY ALUMINIUM MOTORS

TECHNICAL SPECIFICATIONS



Output KW HP	IEC frame	Rated speed (rpm)	Full load current I _n (A) 400V	Efficiency η %			Power Factor cosφ			Locked rotor current I _L /I _n	Locked rotor torque T _L /T _n	Break- down torque T _b /T _n	Sound LP dB(A)	Moment of inertia J(kg·m ²)	Weight (kg)	
				100	75	50	100	75	50							
3000 min⁻¹(2poles) 50Hz																
0.75	1	80M1	2840	1.78	78.1	78.0	76.7	0.78	0.69	0.57	6.5	3.6	4.0	60	0.00092	9
1.1	1.5	80M2	2930	2.48	81.0	80.8	79.3	0.79	0.72	0.68	6.6	3.7	3.9	60	0.001	11
1.5	2	90S	2890	3.00	82.1	81.8	81.0	0.88	0.83	0.75	6.6	2.1	2.9	60	0.002	14
2.2	3	90L	2890	4.24	84.2	84.7	83.4	0.89	0.86	0.79	7.0	2.3	2.9	59	0.003	16
3	4	100L	2915	5.63	85.4	86.0	85.0	0.90	0.84	0.75	9.6	3.5	4.0	63	0.004	21
4	5.5	112M	2895	7.52	86.3	87.0	86.0	0.89	0.85	0.78	6.9	2.2	3.0	63	0.013	26
5.5	7.5	132S1	2930	10.2	87.5	87.6	86.0	0.89	0.85	0.77	8.2	2.2	3.5	68	0.023	37
7.5	10	132S2	2930	13.8	88.4	88.8	87.6	0.89	0.87	0.81	8.3	2.3	3.4	68	0.025	41
9.2	12.5	132M	2930	16.7	89.6	89.6	89.1	0.89	0.87	0.81	8.2	2.4	3.4	68	0.035	42
11	15	160M1	2940	19.6	89.9	89.7	88.1	0.90	0.87	0.80	7.9	2.6	3.5	71	0.055	99
15	20	160M2	2940	26.5	90.7	90.7	89.5	0.90	0.88	0.81	8.1	2.8	3.5	68	0.064	85
18.5	25	160L	2940	32.2	91.2	91.2	90.1	0.91	0.89	0.84	7.8	2.7	3.3	68	0.073	98
22	30	180M	2950	38.1	91.5	91.2	89.6	0.91	0.88	0.82	8.0	2.4	3.6	68	0.103	113
1500 min⁻¹(4 poles) 50Hz																
0.55	0.75	80M1	1365	1.41	77.0	76.5	73.3	0.73	0.66	0.52	2.8	2.1	2.4	46	0.0035	11
0.75	1	80M2	1390	1.81	79.6	78.6	77.4	0.75	0.69	0.56	4.7	2.5	2.7	47	0.004	12
1.1	1.5	90S	1435	2.53	81.4	81.3	80.2	0.77	0.71	0.59	5.4	2.1	2.6	49	0.005	15
1.5	2	90L	1430	3.31	82.8	82.4	81.9	0.79	0.77	0.66	5.4	2.1	2.5	51	0.006	18
2.2	3	100L1	1440	4.65	84.3	84.4	83.2	0.81	0.75	0.64	6.8	3.0	3.2	51	0.007	23
3	4	100L2	1430	6.25	85.5	85.5	85.0	0.81	0.75	0.65	6.5	2.9	2.9	51	0.009	27
4	5.5	112M	1445	8.19	87.0	86.8	85.8	0.81	0.75	0.70	7.1	2.7	2.8	55	0.017	31
5.5	7.5	132S	1460	11.0	87.8	87.6	87.2	0.82	0.77	0.68	7.3	2.4	2.9	55	0.037	45
7.5	10	132M	1460	14.7	89.0	88.7	88.1	0.83	0.79	0.70	7.5	2.6	2.8	55	0.045	58
9.2	12.5	160M	1460	17.8	90.0	90.0	89.4	0.83	0.80	0.72	7.6	2.5	2.8	55	0.075	50
11	15	160M	1470	20.7	90.3	90.2	90.0	0.85	0.81	0.73	7.8	2.6	3.1	63	0.105	95
15	20	160L	1470	27.7	91.0	90.7	90.4	0.86	0.82	0.75	7.4	2.5	2.8	63	0.112	110
18.5	25	180M	1470	34.0	91.3	91.0	90.9	0.86	0.84	0.78	7.4	2.4	3.2	62	0.166	145
22	30	180L	1470	40.2	91.8	91.9	91.2	0.86	0.82	0.72	8.0	2.8	3.4	62	0.186	160
1000 min⁻¹(6 poles) 50Hz																
0.37	0.5	80M1	915	1.09	70.9	69.4	68.8	0.69	0.61	0.51	3.8	2.1	2.2	44	0.0021	11
0.55	0.75	80M2	925	1.55	74.1	72.8	68.7	0.69	0.60	0.52	4.4	2.1	2.3	46	0.0032	14
0.75	1	90S	945	2.03	76.0	75.5	73.8	0.70	0.62	0.50	3.8	1.6	2.2	45	0.004	13
1.1	1.5	90L	945	2.90	78.3	77.5	75.9	0.70	0.63	0.51	4.0	1.7	2.2	45	0.005	15
1.5	2	100L	930	3.82	79.8	78.1	77.8	0.71	0.64	0.55	3.6	1.6	2.1	47	0.008	20
2.2	3	112M	950	5.39	81.8	81.7	80.4	0.72	0.70	0.60	4.9	2.0	2.3	46	0.013	24
3	4	132S	970	6.93	83.3	83.2	82.2	0.75	0.71	0.56	6.8	2.7	3.0	50	0.003	32
4	5.5	132M1	970	8.86	84.6	84.1	83.6	0.77	0.70	0.58	7.1	2.8	3.0	50	0.04	42
5.5	7.5	132M2	970	11.8	86.0	86.0	85.4	0.78	0.71	0.60	7.6	3.1	3.1	53	0.05	50
7.5	10	160M	970	16.1	87.4	87.1	85.8	0.77	0.74	0.63	6.2	2.5	2.6	55	0.12	75
9.2	12.5	160L	970	19.5	88.5	88.2	86.1	0.77	0.74	0.62	6.2	2.2	2.7	57	0.15	90
11	15	160L	970	22.9	88.9	88.5	87.6	0.78	0.74	0.63	6.4	2.7	2.6	57	0.23	95
15	20	180L	980	29.7	89.9	90.0	88.5	0.81	0.74	0.62	7.6	2.8	3.3	57	0.34	130
750 min⁻¹(8 poles) 50Hz																
0.37	0.5	90S	680	1.30	70.8	68.9	66.7	0.58	0.53	0.48	3.6	2.3	2.9	46	0.0046	11
0.55	0.75	90L	695	1.89	71.3	69.5	67.8	0.59	0.54	0.50	3.6	2.3	2.8	45	0.0052	14
0.75	1	100L1	700	2.42	73.3	72.1	71.7	0.61	0.57	0.53	4.3	2.6	2.6	47	0.0073	19
1.1	1.5	100L2	700	3.39	75.5	75.1	74.6	0.62	0.58	0.57	4.2	2.8	2.9	47	0.022	24
1.5	2	112M	700	4.24	77.3	77.0	75.3	0.66	0.62	0.58	3.7	2.0	2.4	49	0.028	33
2.2	3	132S	710	5.90	80.3	80.0	79.5	0.67	0.63	0.60	4.5	2.0	2.6	50	0.04	45
3	4	132M	715	7.78	81.9	81.6	80.8	0.68	0.66	0.64	4.8	2.2	2.7	50	0.05	52
4	5.5	160M1	715	9.55	82.8	82.6	81.6	0.73	0.71	0.67	4.6	1.9	2.5	53	0.09	90
5.5	7.5	160M2	720	12.7	84.5	84.3	82.3	0.74	0.70	0.68	4.8	1.9	2.5	53	0.10	100
7.5	10	160L	720	17.0	86.0	86.1	85.2	0.74	0.71	0.67	5.4	2.3	2.7	50	0.11	115
9.2	12.5	180M	720	20.6	87.2	87.0	86.1	0.74	0.72	0.69	5.7	2.3	2.6	55	0.18	150
11	15	180L	725	24.5	87.7	87.5	86.8	0.74	0.72	0.70	5.9	2.3	2.7	55	0.22	170

High efficiency motors IEC60034-30,IE2 code

MOUNTING AND OVERALL DIMENSIONS

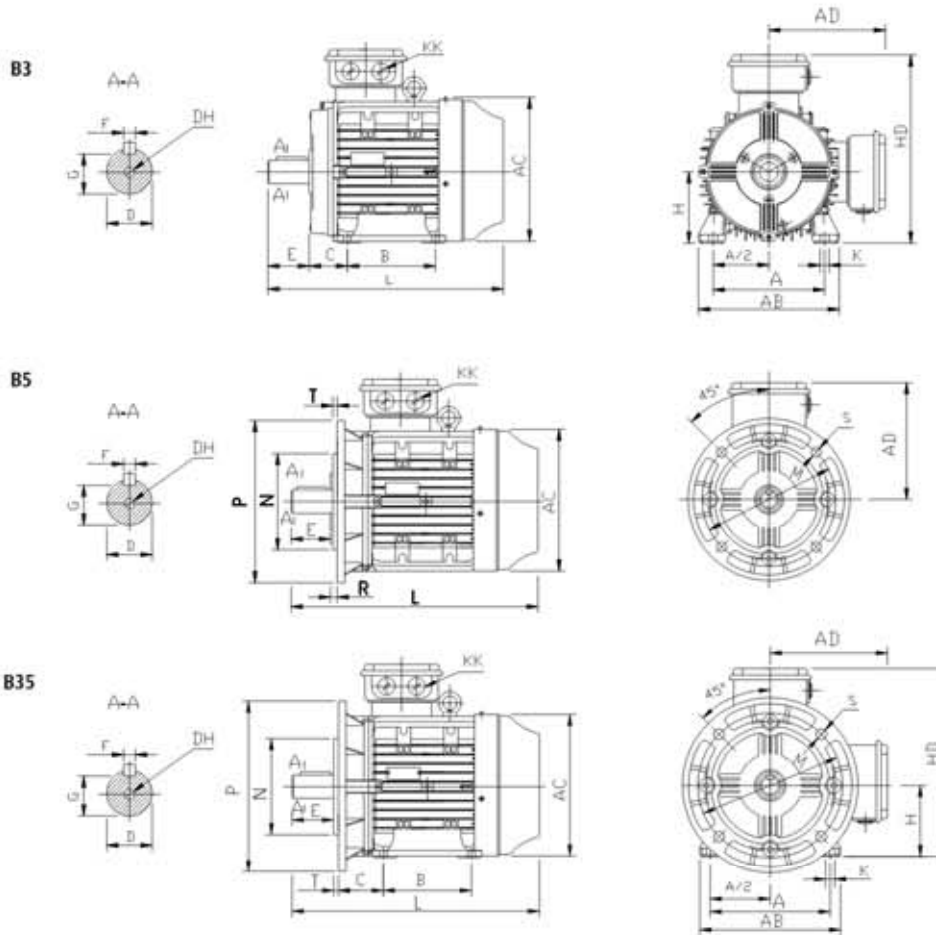

Frame size	Mounting dimensions(mm)													Overall dimensions(mm)									
	A	A/2	B	C	D	DH	E	F	G	H	K	KK	M	N	P	R	S	T	AB	AC	AD	HD	L
80M	125	62.5	100	50	19	M6x16	40	6	15.5	80	4-φ10	M20x1.5	165	130	200	0	4-φ12	3.5	165	160	150	230	315
90S	140	70	100	56	24	M8x20	50	8	20	90	4-φ10	M25x1.5	165	130	200	0	4-φ12	3.5	190	185	160	250	320
90L	140	70	125	56	24	M8x20	50	8	20	90	4-φ10	M25x1.5	165	130	200	0	4-φ12	3.5	190	185	160	250	335
100L	160	80	140	63	28	M10x22	60	8	24	100	4-φ12	M25x1.5	215	180	250	0	4-φ15	4	210	205	175	275	390
112M	190	95	140	70	28	M10x22	60	8	24	112	4-φ12	M25x1.5	215	180	250	0	4-φ15	4	240	230	185	300	400
132S	216	108	140	89	38	M12x28	80	10	33	132	4-φ12	M32x1.5	265	230	300	0	4-φ15	4	275	265	200	345	445
132M	216	108	178	89	38	M12x28	80	10	33	132	4-φ12	M32x1.5	265	230	300	0	4-φ15	4	275	265	200	345	485
160M	254	127	210	108	42	M16x36	110	12	37	160	4-φ15	M40x1.5	300	250	350	0	4-φ19	5	315	315	245	405	615
160L	254	127	254	108	42	M16x36	110	12	37	160	4-φ15	M40x1.5	300	250	350	0	4-φ19	5	315	315	245	405	660
180M	279	139.5	241	121	48	M16x36	110	14	42.5	180	4-φ15	M40x1.5	300	250	350	0	4-φ19	5	350	355	265	445	690
180L	279	139.5	279	121	48	M16x36	110	14	42.5	180	4-φ15	M40x1.5	300	250	350	0	4-φ19	5	350	355	265	445	730

MOUNTING AND OVERALL DIMENSIONS

B14

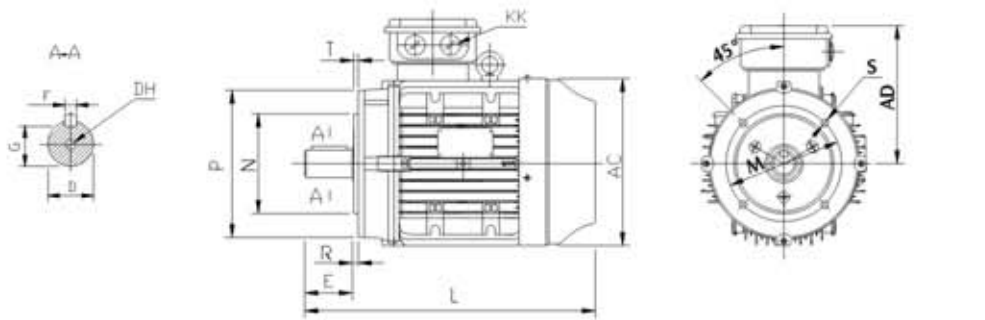

B34

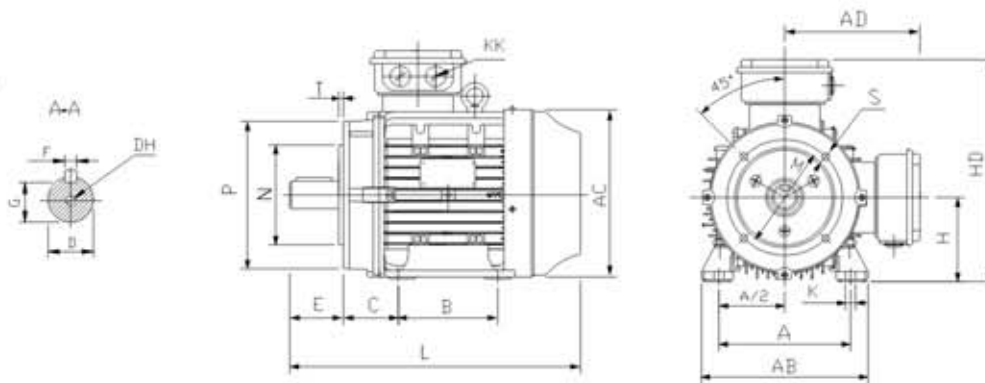

Frame size	Mounting dimensions(mm)																Overall dimensions(mm)						
	A	A/2	B	C	D	DH	E	F	G	H	K	KK	M	N	P	R	S	T	AB	AC	AD	HD	L
80M	125	62.5	100	50	19	M6x16	40	6	15.5	80	4-φ10	M20x1.5	100	80	120	0	4-M6	3	165	160	150	230	315
90S	140	70	100	56	24	M8x20	50	8	20	90	4-φ10	M25x1.5	115	95	140	0	4-M8	3	190	185	160	250	320
90L	140	70	125	56	24	M8x20	50	8	20	90	4-φ10	M25x1.5	115	95	140	0	4-M8	3	190	185	160	250	335
100L	160	80	140	63	28	M10x22	60	8	24	100	4-φ12	M25x1.5	130	110	160	0	4-M8	3.5	210	205	175	275	390
112M	190	95	140	70	28	M10x22	60	8	24	112	4-φ12	M25x1.5	130	110	160	0	4-M8	3.5	240	230	185	300	400
132S	216	108	140	89	38	M12x28	80	10	33	132	4-φ12	M32x1.5	165	130	200	0	4-M10	4	275	265	200	345	445
132M	216	108	178	89	38	M12x28	80	10	33	132	4-φ12	M32x1.5	165	130	200	0	4-M10	4	275	265	200	345	485

VIBRATION

Motor type	speed r/min	vibration mm/s
80-132	600-3600	0.71
132-180	600-3600	1.12

MOTOR SPARE PART LIST/DRAWING

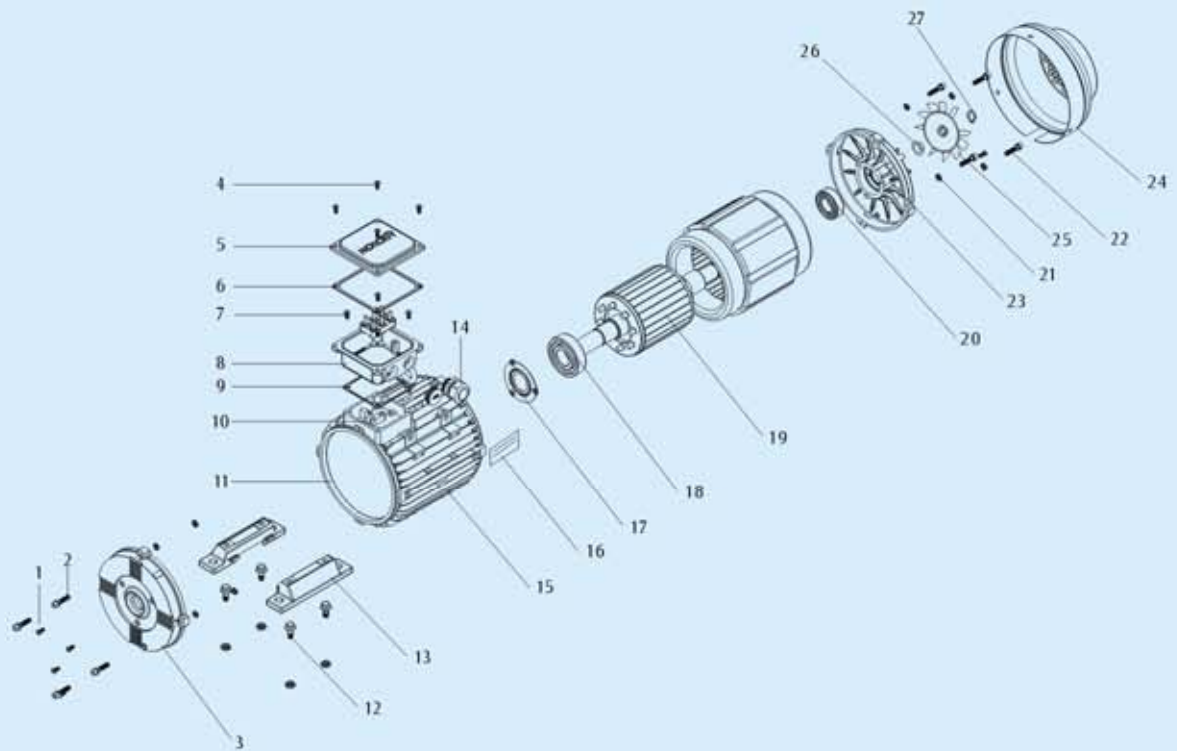

1. Washer
2. Mounting studs screws
3. End shield B3
4. Screws for fixing terminal box(cover)IP55
5. Terminal box cover
6. Terminal seal IP55
7. Screws for fixing terminal box(base)IP55
8. Terminal box base
9. Terminal seal IP55
10. Terminal board complete with components
11. Wound stator
12. Screws for fixing removable feet
13. Removable feet
14. Cable gland

15. Frame
16. Name plate
17. Spring washer
18. Bearing(DE)
19. Rotor with shaft
20. Bearing (NDE)
21. Washer
22. Mounting studs screws
23. NDE shield
24. Fan cover
25. Fan
26. Oilseal
27. Circlip

BEARINGS

Frame size	Driving End	Non-driving End
80	6204-2Z/C3	6203-2Z/C3
90	6205-2Z/C3	6204-2Z/C3
100	6306-2Z/C3	6205-2Z/C3
112	6306-2Z/C3	6205-2Z/C3
132	6208-2Z/C3	6206-2Z/C3
160	6209-2Z/C3	6209-2Z/C3
180-2P	6211/C3	6211/C3
180-4-8P	6311/C3	6211/C3