

DIESEL ENGINE | Overall dimensions and installation

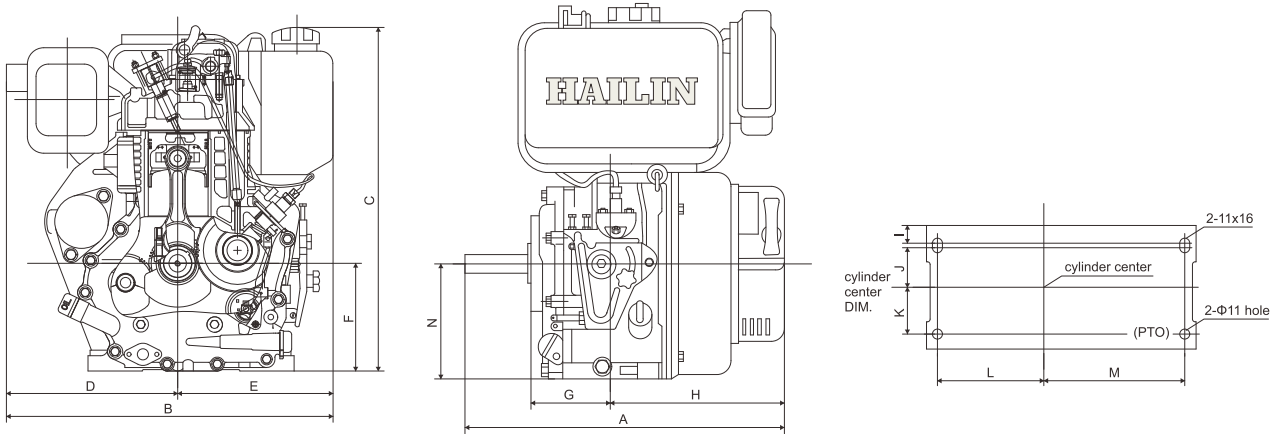

	HL170FA	HL178FA	HL186FA	HL188FV
A	324	358	392	392
B	392	421	470	470
C	416	450	494	498
D	218	218	247	247
E	192	203	223	223
F	130	145	155	155
G	86	96	105	105
H	185	199	224	224
I	5	5	5	5
J	36.5	41.5	43.5	43.5
K	38.5	43.5	51.5	51.5
L	95	104	117	117
M	115	144	155	155
N	160	171.5	173.7	173.7

Unit: mm

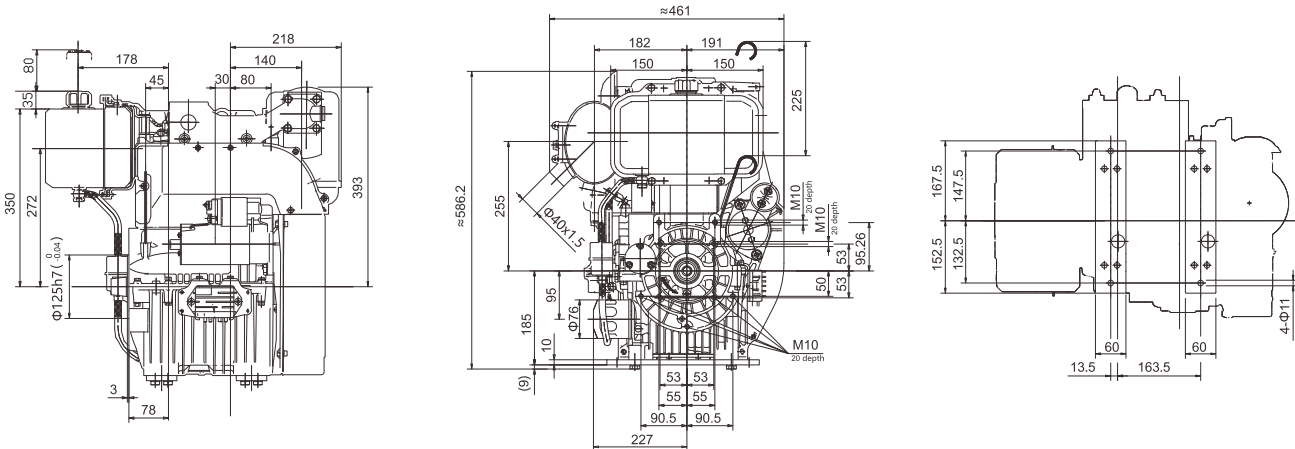

HL292FE

Model	HL186FA
Type	Single-cylinder, Vertical 4-stroke air cooled diesel engine
Displacement	418 cc
Compression Ratio	20 : 1
Bore x Stroke	86×72 mm
Maximum Output	6.5kW (8.8hp) @3000rpm; 7.1kW (9.6hp) @3600rpm
Continuous Output	5.7kW (7.7hp) @3000rpm; 6.3kW (8.6hp) @3600rpm
Power Take Off	Crankshaft
Revolution Direction	Counterclockwise (Viewed from output shaft)
Cooling System	Forced air by flywheel fan
Lubricating System	Forced lubrication and splash lubrication
Starting System	Recoil Start
Fuel Tank	5.5 Liters
Lub Oil Capacity	1.6 Liters
Fuel Consumption	312 ml/kW.h @3000rpm; 318 ml/kW.h @3600rpm
Dimension	417x470x494 mm
Dry Weight	48 kg