

**ACCESSORI PER COMPRESSORI
ACCESSORIES FOR COMPRESSORS
ZUBEHOERE FUER KOMPRESSOREN
ACCESSOIRES POUR COMPRESSEURS**

**124 - 130
131**

Caratteristiche Tecniche:

- Pressione max. di esercizio 10 bar.
- Temperatura dell'ambiente di lavoro compresa fra -10°C e +85°C.
- Materiale: Ottone

Technical Specifications:

- Max. working pressure 10 bar.
- Room temperature ranging from -10°C to +85°C.
- Materials: Brass

Technische Eigenschaften:

- Maximale Betriebsdruck 10 bar.
- Temperatur Arbeitsraum -10°C und +85°C nicht überschreitend.
- Werkstoff: Messing

Caractéristiques Techniques:

- Pression maximale d'exercice 10 bar.
- Température du milieu de travail comprise entre -10°C et +85°C.
- Matériaux: Laiton

**Rubinetto di spurgo con O-Ring
Bleeder tap with O-Ring
Ablasshahn mit O-Ring
Robinet de purge avec O-Ring**

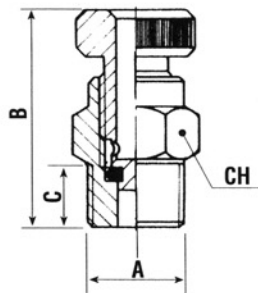
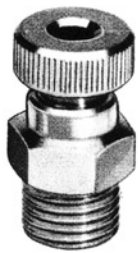

Codice Code	A	B	C	CH
124.8	G 1/8	31,5	7	13
124.4	G 1/4	27,5	9	13
124.3	G 3/8	27,5	11	18

**Smorzatore di vibrazioni per manometro
Gauge pulsation damper
Stosdämpfer für Manometer
Amortisseur de pusionation pour manomètre** **20÷300 bar**

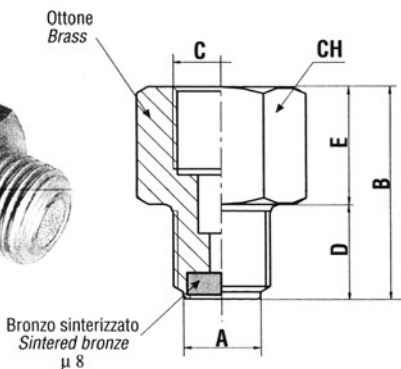
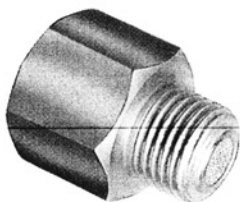

Codice Code	A	B	C	D	E	CH
130.8	G 1/8	25,0	G 1/8	10,0	15	14
130.4	G 1/4	27,0	G 1/4	11,0	16	19
130.3	G 3/8	36,8	G 3/8	16,8	20	25
130.2	G 1/2	46,8	G 1/2	22,8	24	30

**Smorzatore di vibrazioni per manometro
Gauge pulsation damper
Stosdämpfer für Manometer
Amortisseur de pusionation pour manomètre** **0÷20 bar**

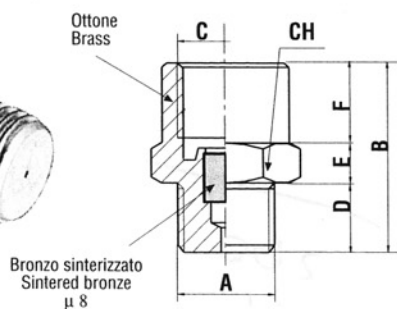
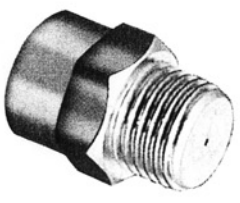

Codice Code	A	B	C	D	E	F	CH
131.8	G 1/8	19	G 1/8	7	4	8	13
131.4	G 1/4	23	G 1/4	9	5	9	16
131.3	G 3/8	27	G 3/8	11	6	10	20
131.2	G 1/2	33	G 1/2	13	7	13	30