



Funzionamento a doppio effetto per cilindro a doppio effetto
Double-stroke for a double acting cylinder

GL290

Descrizione / Codice <i>Description / Code</i>	GL 290
OIL TANK	1
FILLER PLUG	2
OIL FLOW DIVERTER LEVER	3
4 - Pressure porte	1/4 GAS
5 - Pressure porte	1/4 GAS
PRESSURE RELIEF VALVE	6

TIPO TYPE	Cilindrata Flow (cc)	Pressione massima Max pressure (bar)	Peso Weight (Kg) Pump
GL290-17	11	380	3,8
GL290-20	16	280	3,9
GL290-25	25	180	4,0
GL290-28	32	150	4,1
GL290-35	50	100	4,2
Oil tank Lt2			2,2
Oil tank Lt4			2,6

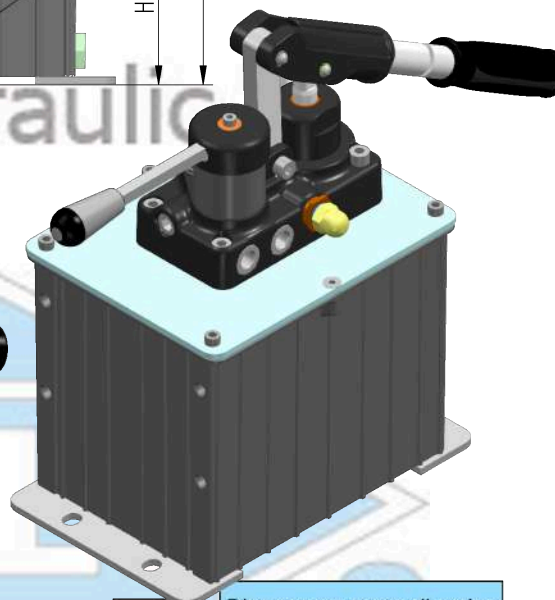
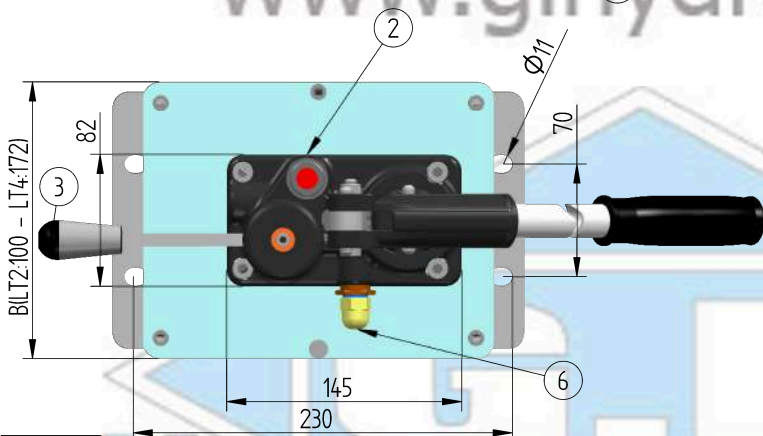
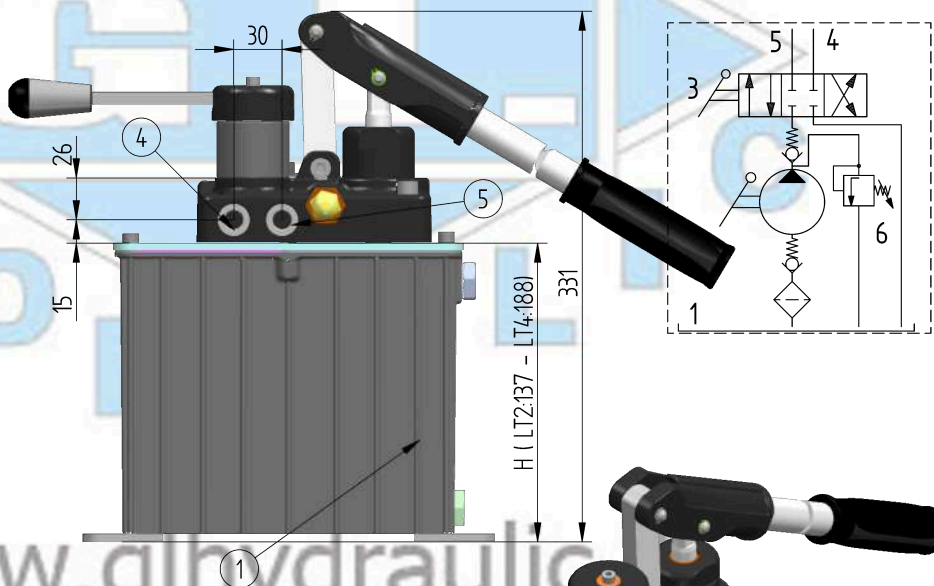

Dati tecnici
indicativi e
non
impegnativi.
L'azienda si
riserva di
apportare
modifiche in
qualsiasi
momento e
senza
preavviso.

Technical
data not
binding.
Modification
s reserved
without
prior notice.

Codice di ordinazione - Ordering code

GL290-	Option 1	17	-DV-	Option 2	S2
		20			S4
		25			
		28			
		35			

Option 1		Option 2	
Displacement		Oil tank	
17	11 cc	S2	2 Litres Oil tank
20	16 cc	S4	4 Litres Oil tank
25	25 cc		
28	32 cc		
35	50 cc		

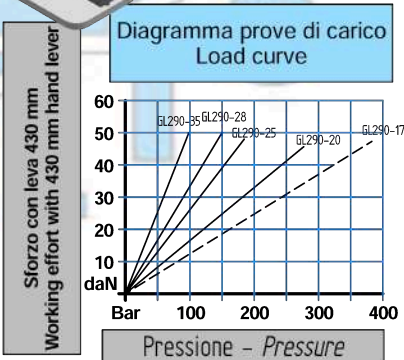

G.L. HYDRAULIC S.R.L.

Via F. Lamborghini, 36 - 40019 Sant' Agata Bolognese (BO) Italy
 Tel. +39 (0)51 6828230 Fax +39(0)51 9599081 http://www.glydraulic.it - E-mail: staff@glydraulic.it
 Cap. Soc. : € 31.200,00 i.v. - R.E.A. : B0399971 - C.F. e P.I. : IT01808760357