

SVCP

VALVOLA NORMALMENTE CHIUSA, PILOTATA
NORMALLY CLOSED, PILOTED POPPET TYPE

2MP
OLEODINAMICA

CARATTERISTICHE TECNICHE TECHNICAL CHARACTERISTICS

Pressione massima Maximum pressure	350 bar (5075 psi)
Portata nominale Nominal Flow	40 l/min (10,6 gpm)
Temperatura di esercizio Operating temperature	-30 / 100 °C
Cavità Cavity	C007
Trafilamento interno Internal leakage	5 cc/min (50 °C; 21 cSt; 200 bar)
Coppia Torque	45-50 Nm
Peso Weight	0,11 kg

SCHEMA IDRAULICO HYDRAULIC SCHEME

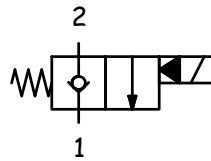

BOBINA COIL

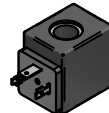

13-39
18 W

pag. CV.CL.001.13

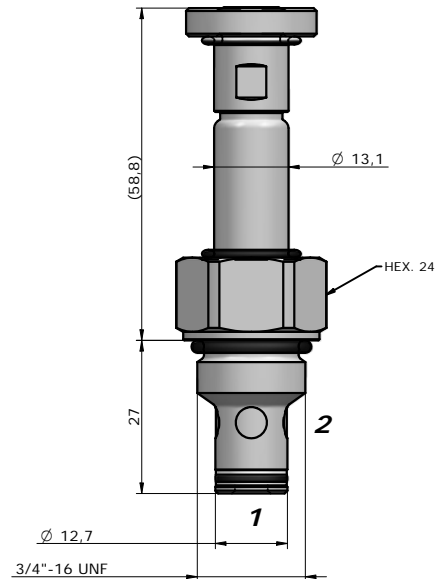

PRESTAZIONI PERFORMANCES

1 --> 2
2 --> 1



DESCRIZIONE DESCRIPTION

Quando la bobina è eccitata, l'otturatore si solleva e fa sì che da 2 a 1 ci sia passaggio libero, in questo modo da 1 a 2 il flusso è molto ristretto.

Quando la bobina è diseccitata, la SVCP agisce come valvola di ritegno che consente il flusso libero da 1 a 2, mentre lo blocca da 2-1.

When the coil is energized the poppets lifts and opens the 2 to 1 flow path. In this operation mode, flow from 1 to 2 is severely restricted.

When the coil is de-energized, the SVCP acts as check valve allowing free flow from 1 to 2, while blocking from 2 to 1.

CODICE D'ORDINAZIONE ORDERING CODE

SVCP-S08-TS1-N-0-D12-D-S200

GUARNIZIONI / SEAL

N = NBR
V = VITON

REGOLAZIONE / REGULATION

0 = SENZA COMANDO MANUALE / NO MANUAL OVERRIDE
1 = VITE / SCREW
2 = SPINGI E GIRA / PUSH AND TWIST
6 = TAPPO PREMUTO / PULL AND HOLD

TENSIONE / VOLTAGE

000 = SENZA BOBINA / WITHOUT COIL
D12 = 12 VDC
D24 = 24 VDC
220 = 220 RAC
D26 = 26 VDC

TIPO CONNETTORE / CONNECTOR TYPE

0 = SENZA BOBINE / WITHOUT COIL
C = CAVI / LEADS
D = DIN 43650
G = DEUTSCH DT04-2P
A = AMP JUNIOR

DIMENSIONE CORPO / SIZE BODY

OMETTERE/OMIT
100
200
101
201
102
202

MATERIALE CORPO / MATERIAL BODY

OMETTERE/OMIT
S = STEEL
A = ALLUMINUM

Via Nicolò Copernico 12/c-d
29027 Casoli Di Gariga - Podenzano (PC) Italy

www.oleodinamica2mp.it
Tel +39 0523 523231
Fax +39 0523 524509

CV.05.009.13

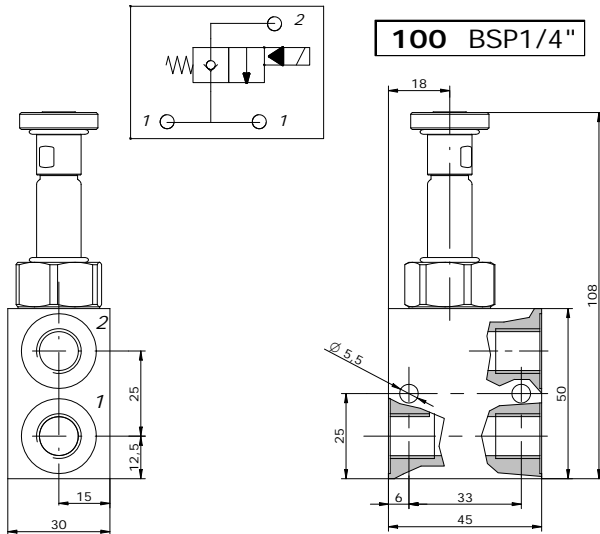

100 BSP1/4"

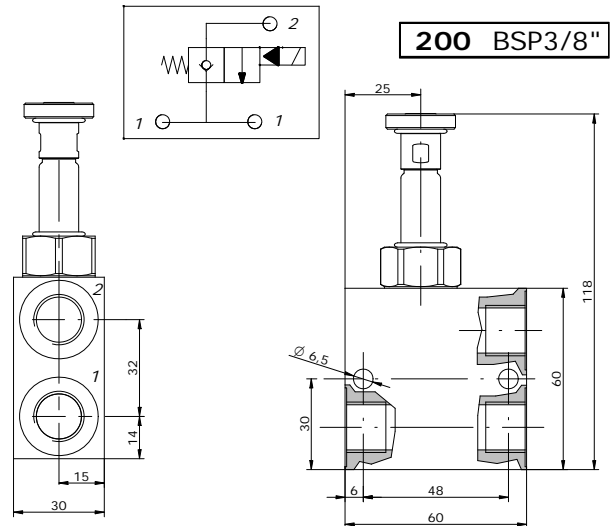

200 BSP3/8"

Peso / weight A : 0,25 kg
Peso / weight S : 0,52 kg

Peso / weight A : 0,34 kg
Peso / weight S : 0,76 kg

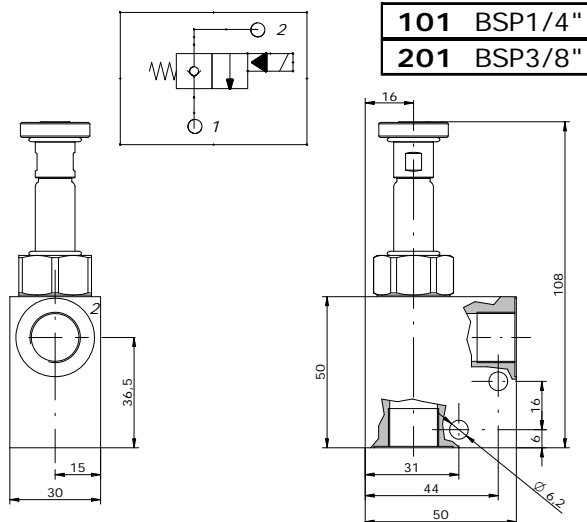

101 BSP1/4"
201 BSP3/8"

Peso / weight A : 0,27 kg
Peso / weight S : 0,57 kg

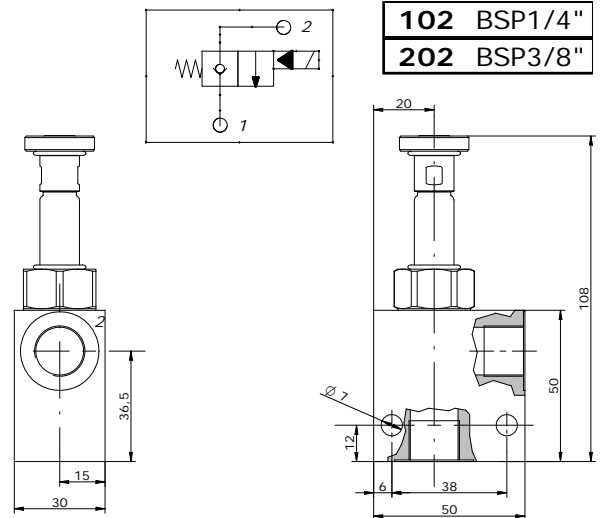

102 BSP1/4"
202 BSP3/8"

Peso / weight A : 0,26 kg
Peso / weight S : 0,56 kg

A RICHIESTA ON REQUEST

Trattamenti superficiali per corpi valvola / Manifold surface treatments

- **ALLUMINIO:** Ossidazione anodica colorata (nero, blu, oro, rosso);
- **ACCIAIO:** Fosfatatura; brunitura

- **ALUMINIUM:** Colored anodizing (black, blue, gold, red);
- **STEEL:** Phosphating; bluing.

NOTE NOTES
