

Equal Tee  
T-Verschraubung  
Union té

**P-TV .....**

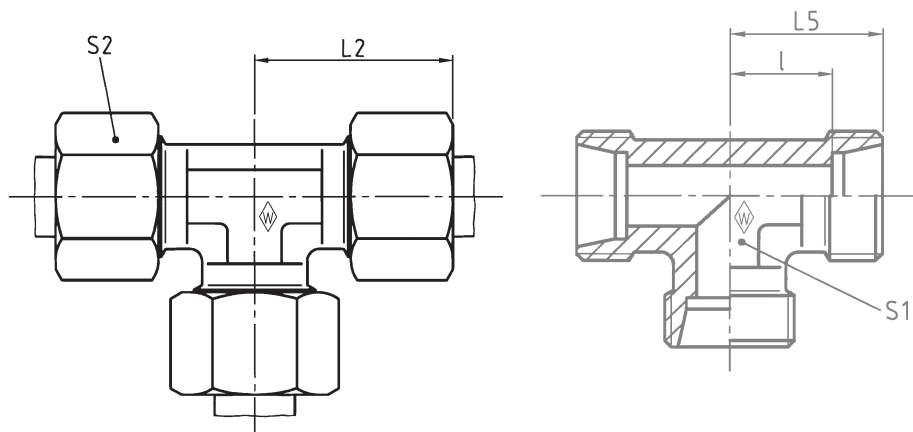

Series	bar	Tube OD	Type	Reference	kg per 100 pcs.						
Reihe	PN	Rohr-AD	Typ	Best.-Nr.	kg per 100 St.						
Série	(psi)	Tube Ø ext.	Désignation	Réf.	kg par 100 p.						
						L <sub>2</sub>	L <sub>5</sub>	l <sub>1</sub>	S <sub>1</sub>	S <sub>2</sub>	
LL	100 (1450)	4	<b>S-TV 4 LL</b>	<b>WAL038600</b>		21	15	11	9	10	
		6	<b>S-TV 6 LL</b>	<b>WAL038602</b>		21	15	9,5	9	12	
		8	<b>S-TV 8 LL</b>	<b>WAL038603</b>		23	17	11,5	12	14	
L	500 (7252)	6	<b>P-TV 6 L</b>	<b>WAL373408</b>		27	19	12	12	14	
		8	<b>P-TV 8 L</b>	<b>WAL373409</b>		29	21	14	12	17	
		10	<b>P-TV 10 L</b>	<b>WAL373410</b>		30	22	15	14	19	
	400 (5801)	12	<b>P-TV 12 L</b>	<b>WAL373411</b>		32	24	17	17	22	
		15	<b>P-TV 15 L</b>	<b>WAL373412</b>	23,2	36	28	21	19	27	
		18	<b>P-TV 18 L</b>	<b>WAL373413</b>	35,4	40	31	23,5	24	32	
		22	<b>P-TV 22 L</b>	<b>WAL373414</b>	44,3	44	35	27,5	27	36	
		250 (3626)	28	<b>P-TV 28 L</b>	<b>WAL373415</b>	61,1	47	38	30,5	36	41
		35	<b>P-TV 35 L</b>	<b>WAL373416</b>	90,1	56	45	34,5	41	50	
S	800 (11603)	42	<b>P-TV 42 L</b>	<b>WAL373417</b>	136,8	63	51	40	50	60	
		6	<b>P-TV 6 S</b>	<b>WAL373418</b>		31	23	16	12	17	
		8	<b>P-TV 8 S</b>	<b>WAL373419</b>		32	24	17	14	19	
	630 (9137)	10	<b>P-TV 10 S</b>	<b>WAL373420</b>		34	25	17,5	17	22	
		12	<b>P-TV 12 S</b>	<b>WAL373421</b>		38	29	21,5	17	24	
		14	<b>P-TV 14 S</b>	<b>WAL373422</b>	28,5	40	30	22	19	27	
		16	<b>P-TV 16 S</b>	<b>WAL373423</b>	35,7	43	33	24,5	24	30	
		20	<b>P-TV 20 S</b>	<b>WAL373424</b>	55,8	48	37	26,5	27	36	
		420 (6091)	25	<b>P-TV 25 S</b>	<b>WAL373425</b>	106,7	54	42	30	36	46
		30	<b>P-TV 30 S</b>	<b>WAL373426</b>	134,9	62	49	35,5	41	50	
400 (5801)	38	<b>P-TV 38 S</b>	<b>WAL373427</b>	202,2	72	57	41	50	60		

L<sub>2</sub> = approximate length with nut tightened  
L<sub>2</sub> = Ungefährmaß bei angezogener Überwurfmutter  
L<sub>2</sub> = longueur approximative, l'écrou étant bloqué