

13.2 - FINECORSA IN TRAZIONE E SPINTA NORMALMENTE CHIUSO

13.2 - END STROKE VALVES, NORMALLY CLOSED

TIPO/TYPE
V-FCR 2T



SCHEMA IDRAULICO
HYDRAULIC DIAGRAM

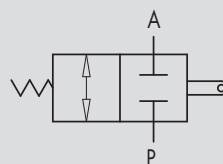

IMPIEGO:

Valvola utilizzata per aprire il passaggio di olio in un circuito idraulico (valvola normalmente chiusa). L'apertura della valvola è ottenuta azionando il cursore in trazione o spinta.

MATERIALI E CARATTERISTICHE:

Corpo: ghisa

Componenti interni: acciaio temprato termicamente e rettificato

Guarnizioni: BUNA N standard

Tenuta: trafilamento trascurabile

MONTAGGIO:

Collegare A e P indifferentemente al distributore e al circuito. Quando il cursore è azionato il flusso è libero in entrambe le direzioni, viceversa il flusso è bloccato.

USE AND OPERATION:

This valve is used to enable oil inlet in a hydraulic circuit (normally closed valve). The valve opens by pulling or pushing the slider.

MATERIAL AND FEATURES

Body: cast iron

Internal parts: grounded and hardened steel

Seals: BUNA N standard

Tightness: minor leakage

APPLICATIONS:

Connect independently A and P to the distributor and to the circuit. When slider is operating, flow is free in both directions, vice versa it is blocked.

PERDITE DI CARICO PRESSURE DROPS CURVE

Temperatura olio: 50°C - Viscosità olio: 30 cSt
Oil temperature: 50°C - Oil viscosity: 30 cSt

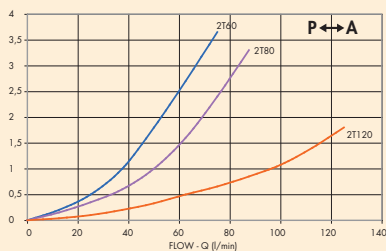



CODICE CODE	SIGLA TYPE	PORTATA MAX MAX FLOW L _v /min	PRESSIONE MAX MAX PRESSURE Bar	INIZIO APERTURA START OPENING mm	FORZA POWER Kg (±10%)	CORSA MAX MAX STROKE mm	FORZA POWER Kg (±10%)
V0820	VFCR 2T 60	60	350	7	6,5	20,5	18
V0822	VFCR 2T 80	80	350	7	6,5	20,5	18
V0823	VFCR 2T 120	120	350	9	33	15,5	50

VFCR 2T 60 - 80

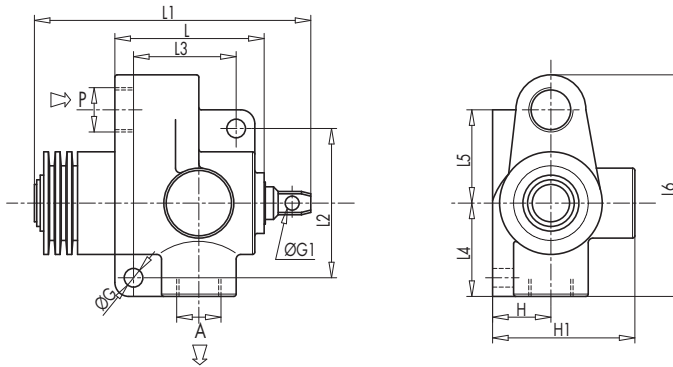

VFCR 2T 120

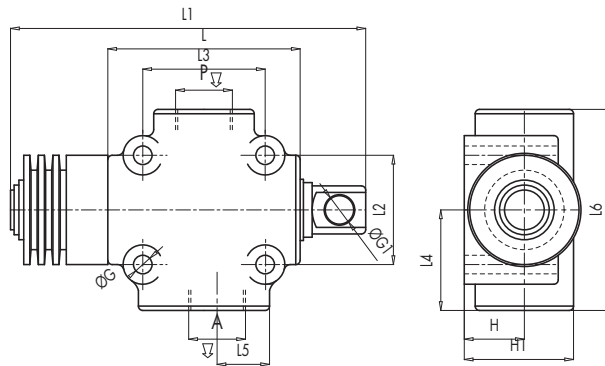

13

CODICE CODE	SIGLA TYPE	A - P	L	L1	L2	L3	L4	L5	L6	ØG	ØG1	H	H1	PESO WEIGHT
		GAS	mm	mm	mm	mm	mm	mm	mm	mm	mm	mm	mm	Kg
V0820	VFCR 2T 60	G 3/8"	69	130	66	45	45	41	103	8,5	6,5	26	68	1,648
V0822	VFCR 2T 80	G 1/2"	69	130	66	45	45	41	103	8,5	6,5	26	68	1,652
V0823	VFCR 2T 120	G 3/4"	88	179	50	56	46	23,5	92	8,5	13	27,5	50	2,204