

CETOP 3: Manifold Block

Features:

- Cast Iron Construction – Phosphated
- 345 Bar Maximum Working Pressure
- 40 L/min Maximum Flow Rate
- P and T Ports – 1/2" BSP
- A and B Ports – 3/8" BSP

Benefits:

- Reduced Fitting and Installation Costs
- Compact design of valve circuits
- Reduces leak Paths
- Allows for easy modification to valve assembly stacks

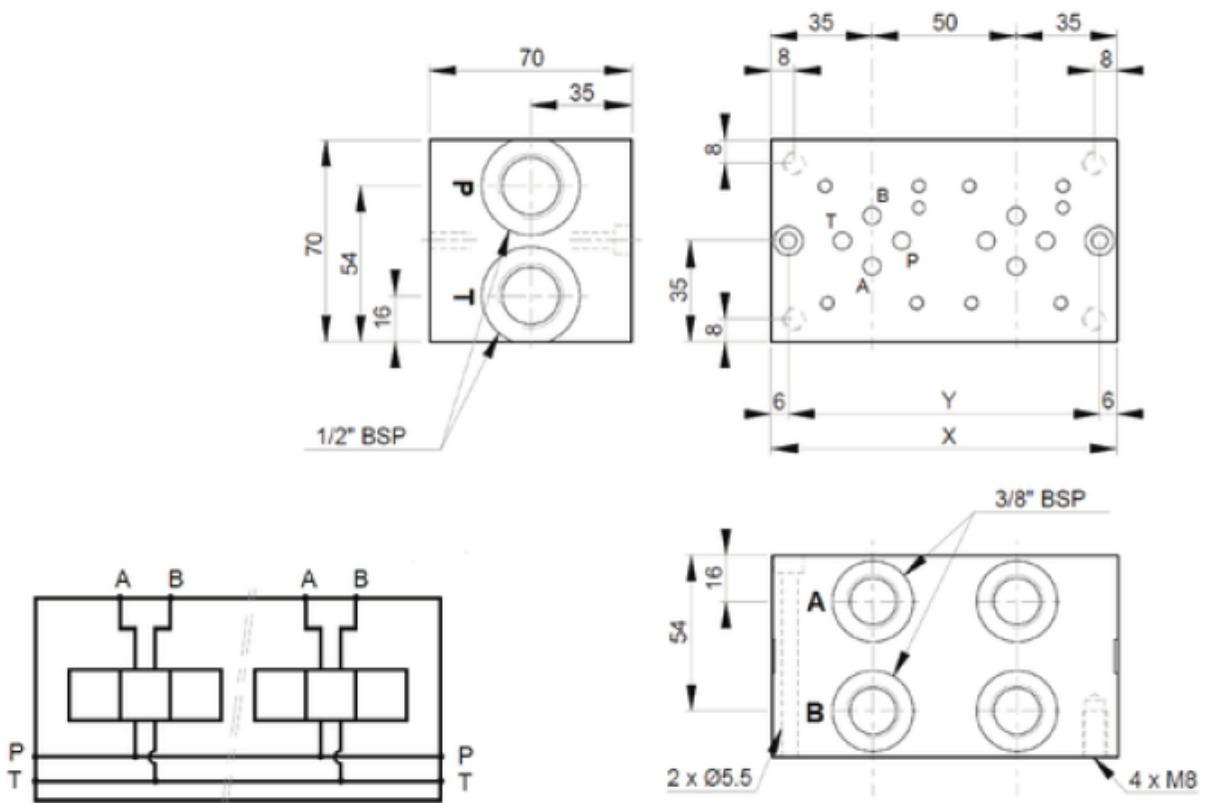

Part Number	No. Stations	X (mm)	Y (mm)
CM3-1G	1	70	58
CM3-2G	2	120	108
CM3-3G	3	170	158
CM3-4G	4	220	208
CM3-5G	5	270	258
CM3-6G	6	320	308

CETOP 3: Manifold Block

Features:

- Aluminium Construction
- 207 Bar Maximum Working Pressure
- 40 L/min Maximum Flow Rate
- P and T Ports – 1/2" BSP
- A and B Ports – 3/8" BSP

Benefits:

- Reduced Fitting and Installation Costs
- Compact design of valve circuits
- Reduces leak Paths
- Allows for easy modification to valve assembly stacks

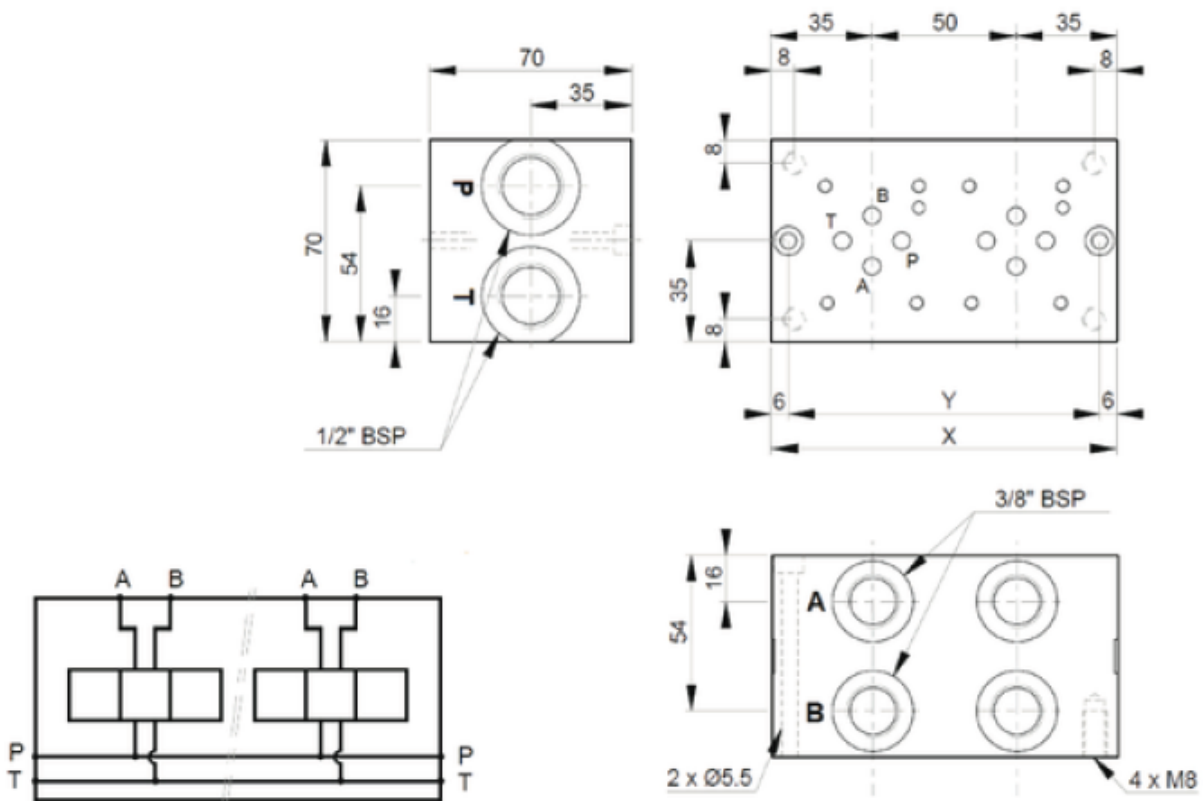

Part Number	No. Stations	X (mm)	Y (mm)
CM3-1G/ALU	1	70	58
CM3-2G/ALU	2	120	108
CM3-3G/ALU	3	170	158
CM3-4G/ALU	4	220	208
CM3-5G/ALU	5	270	258
CM3-6G/ALU	6	320	308

CETOP 3: Side Entry Subplate

Features:

- Cast Iron Construction – Phosphated
- 345 Bar Maximum Working Pressure
- 3/8" BSP Ported

Benefits:

- Reduced Fitting and Installation Costs
- Compact design of valve circuits
- Reduces leak Paths

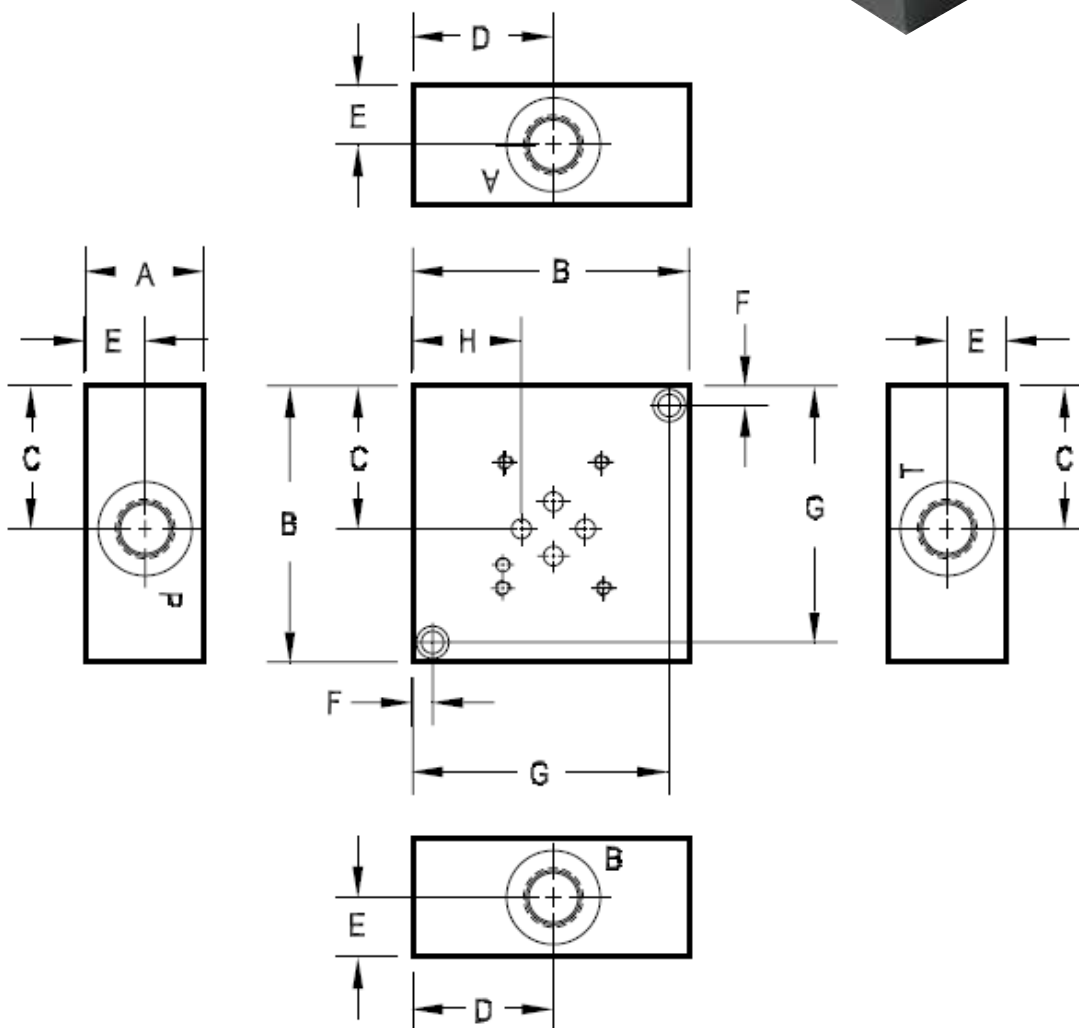

Part Number	A	B	C	D	E	F	G	H
CSP-03	2.45	63.5	33.3	31.8	12.7	6.4	57.2	22.4

CETOP 3: Auxiliary Plates – Blanking Plate

Features:

- Mild Steel Construction – Phosphated
- 345 Bar Maximum Working Pressure
- Supplied with Seals

Benefits:

- Compact design of valve circuits

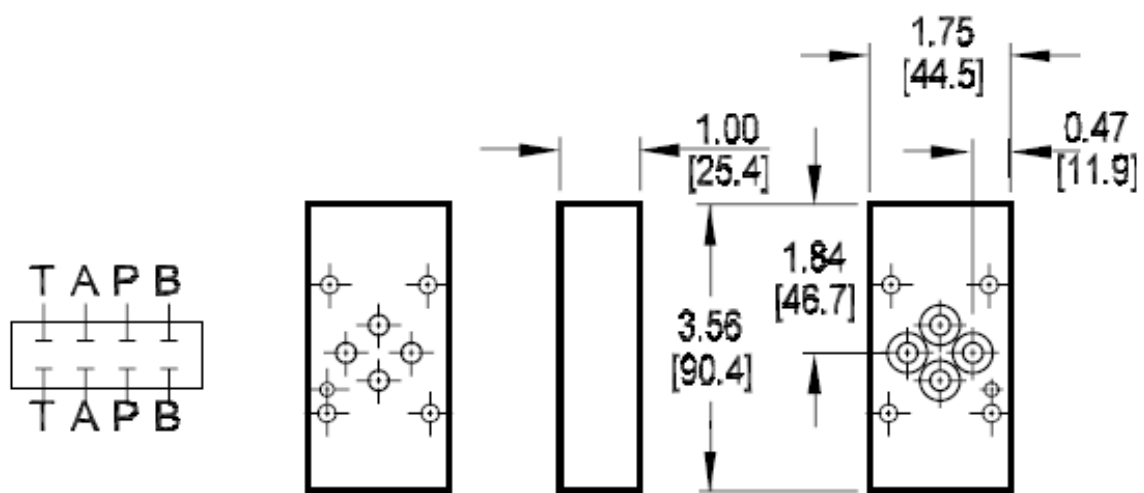

Part Number
CBP-03

Part Number

CBP-03

CETOP 3: Auxiliary Plates – Tapping Plate A & B

Features:

- Mild Steel Construction – Phosphated
- 345 Bar Maximum Working Pressure
- Supplied with Seals

Benefits:

- Compact design of valve circuits

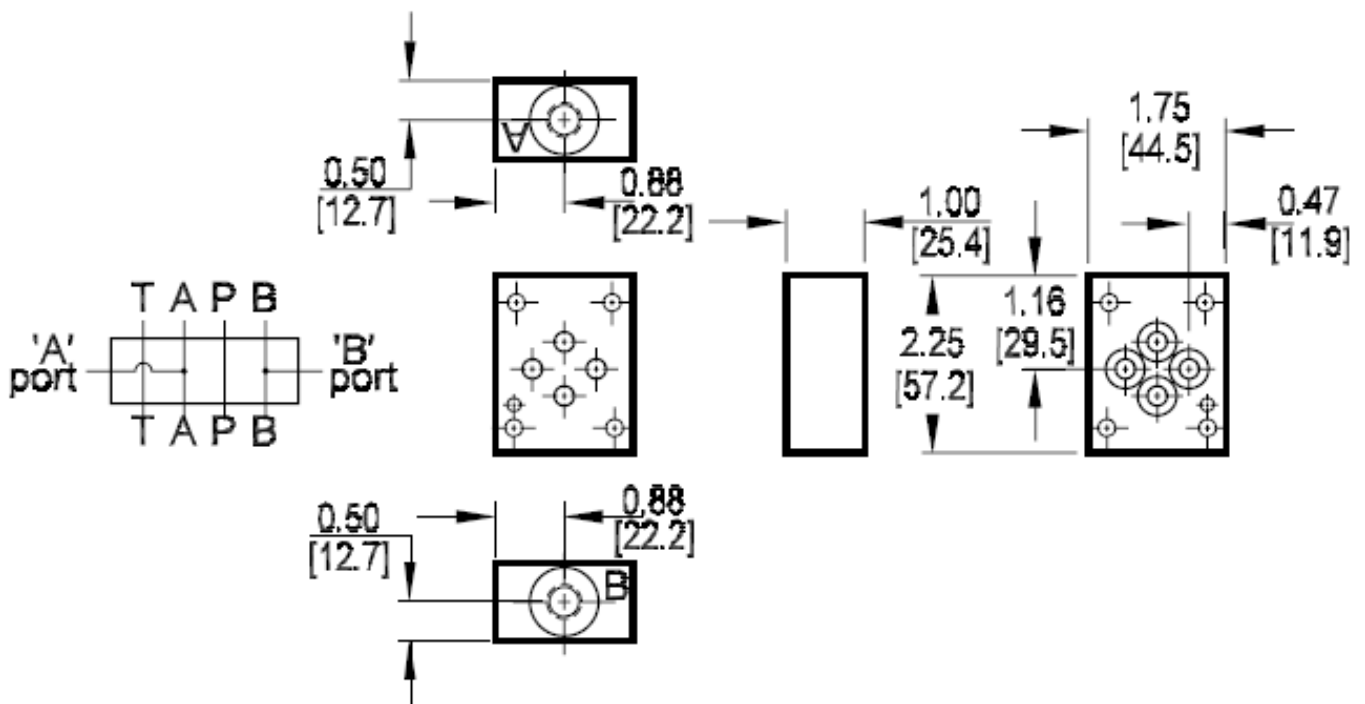

Part Number

CTP-AB-03

Pressure Test Points

A and B Lines

CETOP 3: Auxiliary Plates – Tapping Plate P and T

Features:

- Mild Steel Construction – Phosphated
- 345 Bar Maximum Working Pressure
- Supplied with Seals

Benefits:

- Compact design of valve circuits

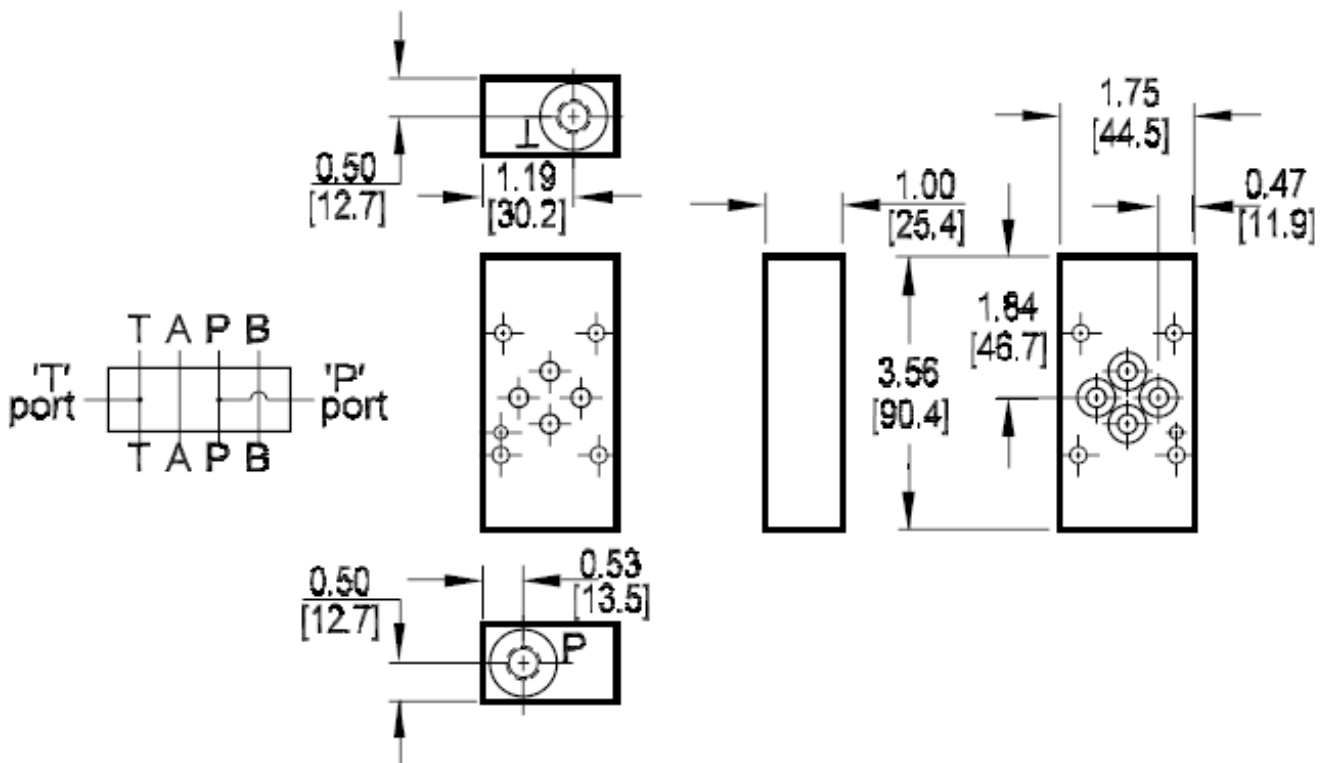

Part Number

CTP-PT-03

Pressure Test Points

P Line