

Note:

All dimensions are in Millimetres and are for reference only and drawings should be obtained for installation purposes. Certified Dim, Drgs, are available if required. Technical information sheets are sent with each cooler, or earlier if requested. We reserve the right to change details with out prior notice.

CAUTION - NOISE DATA

The noise values are given by the fan manufacturers in dBA and apply to 'free field' conditions. In practice different conditions lead to sound reflection reverberation and resonance, dependent on insulation details. The resulting actual noise levels can be in excess of the nominal figure shown.

Please note: Fan powers and amps are for guidance only:

Cooler size	Cooling at 100°C DT KW	Radiator Pressure Rating	Noise level dBA x 1 MTR	Radiator Ports Sizes	Max Oil Flow Rate LPM	Fan Power kW #	Amps At 12 V	Amps At 24 V	Approx KG (dry)
GDDC 2	1.8	7 Bar	44	½" BSP	75	0.01	0.52	0.25	2.0
GDDC 6	7	7 Bar	55	¾" BSP	75	0.02	1.40	0.70	3.0
GDDC 11	11	7 Bar	68	¾" BSP	75	0.09	6.5	3.6	4.0
GDDC 15	15	7 Bar	72	¾" BSP	150	0.1	7.7	3.9	4.0
GDDC 21	20	7 Bar	72	¾" BSP	150	0.1	7.7	3.9	5.0
GDDC 38	38	20 Bar		1½" BSP	230	0.3	20.0	11.6	
GDDC 44	44	20 Bar		1½" BSP	240	0.3	20.0	11.6	
GDDC 52	52	20 Bar		1½" BSP	240	0.3	20.7	10	
GDDC 55	55	20 Bar		1½" BSP	190	0.3	20.7	10	
GADC 65	65	20 Bar		1½" BSP	260	0.3	20.7	10	
GADC 76	76	20 Bar		2" BSP	400	0.3	20.7	10	
GDDC 79	79	20 Bar		2" BSP	300	2 x 0.3	2 x 14.7	2 x 8.7	
GADC 85	85	20 Bar		2" BSP	400	0.3	20.7	10	
GADC 117	117	20 Bar		2" BSP	400	2 x 0.3	2 x 20.0	2 x 11.6	
GADC 120	120	20 Bar		2" BSP	400	2 x 0.3	2 x 18.6	2 x 9.3	
GADC 156	156	20 Bar		2" BSP	400	2 x 0.3	2 x 20.7	2 x 10	
GADC 165	165	20 Bar		2" BSP	400	2 x 0.3	2 x 20.7	2 x 10	

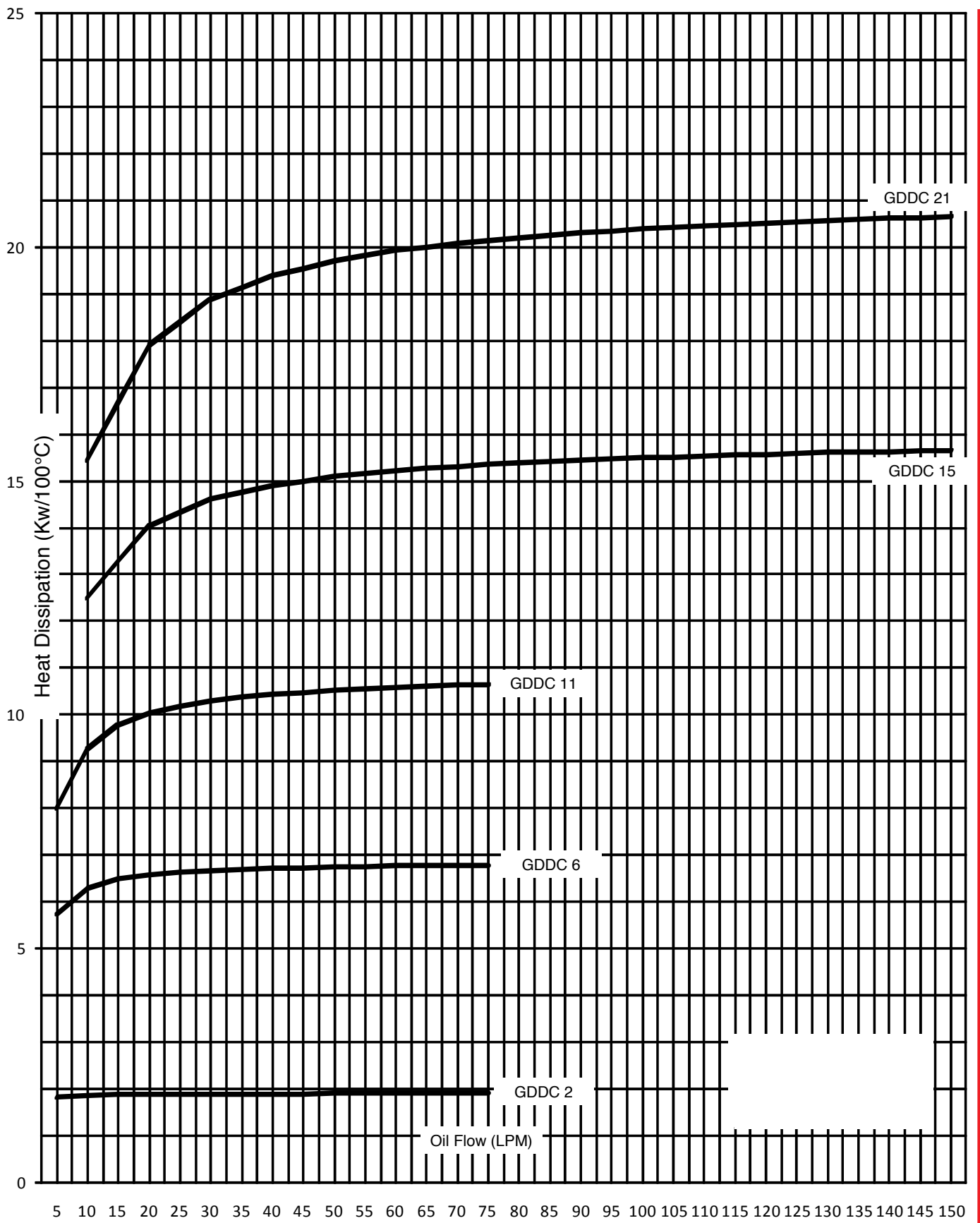

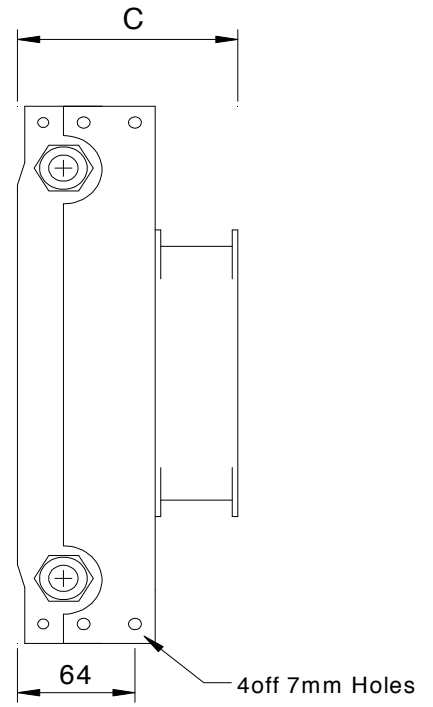
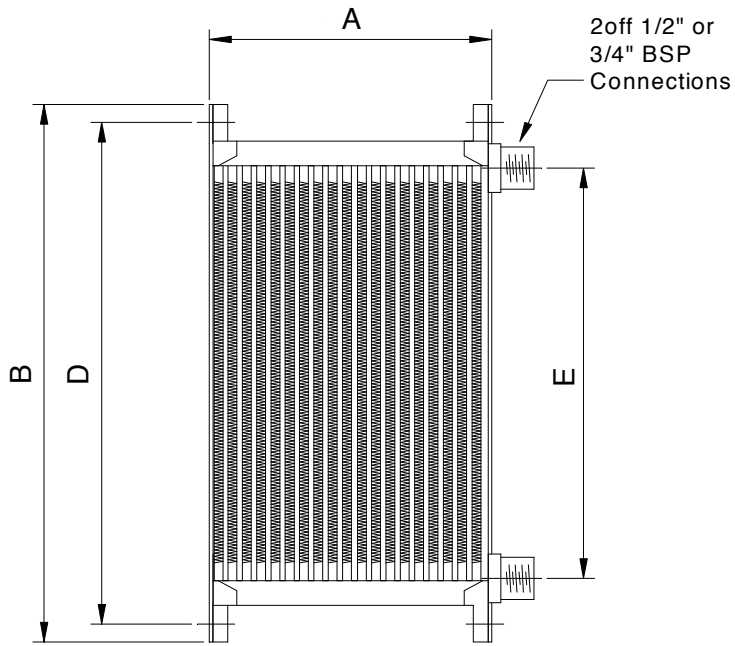

Cooler size	A	B	C	D	E
GDAC 2	133	210	120	188	132
GDAC 6	155	330	120	308	252

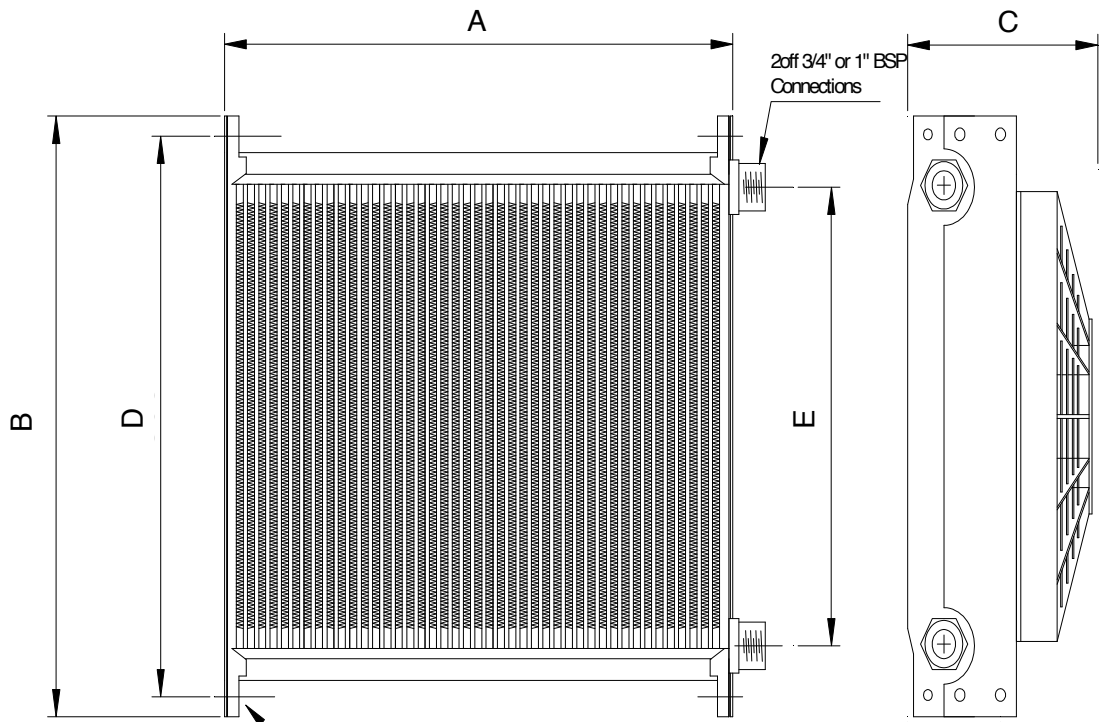

Cooler	A	B	C	D	E
GDDC 11	205	330	165	308	252
GDDC 15	275	330	150	308	252
GDDC 21	350	330	165	318	252

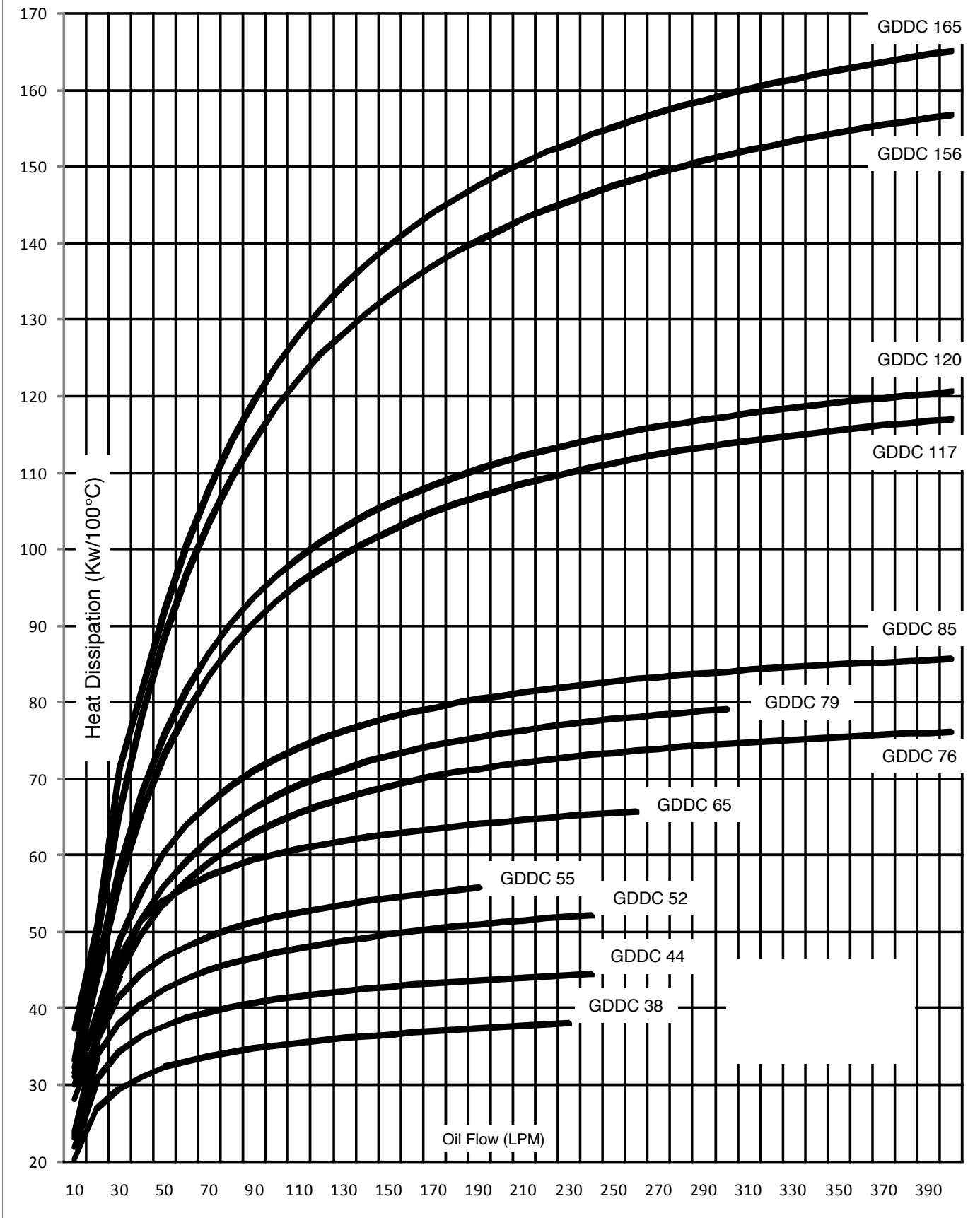

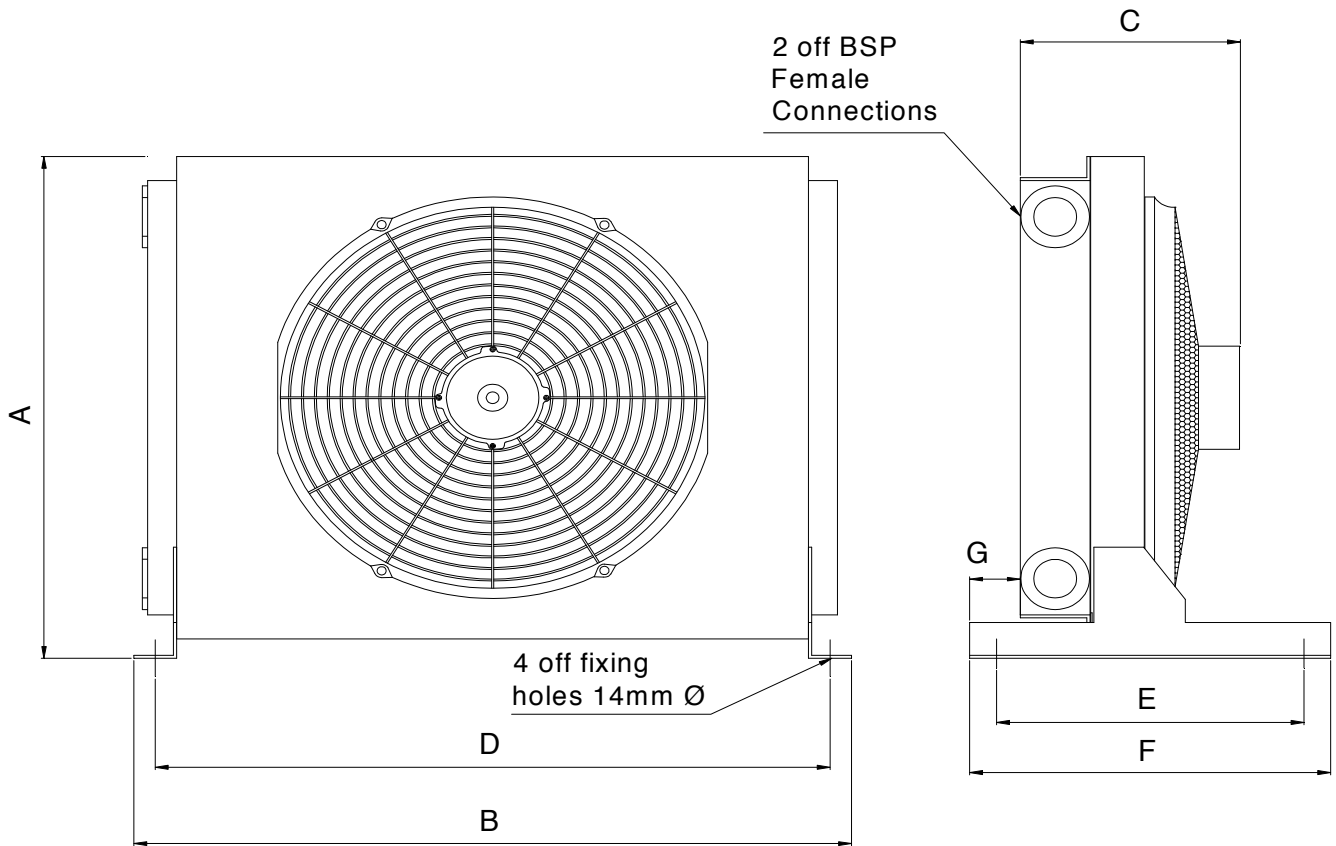

Cooler Model	A	B	C	D	E	F	G	Connection Size
GDDC 38	463	518	215	478	286	336	47	1½" BSP
GDDC 44	520	568	215	528	286	336	47	1½" BSP
GDDC 52	520	568	215	528	286	336	47	1½" BSP
GDDC 55	520	668	215	628	286	336	47	1½" BSP
GDDC 65	672	696	215	656	286	336	47	1½" BSP
GDDC 76	672	696	235	656	286	336	17	2" BSP
GDDC 85	804	846	285	806	286	336	17	2" BSP

MODEL - GDDC 79

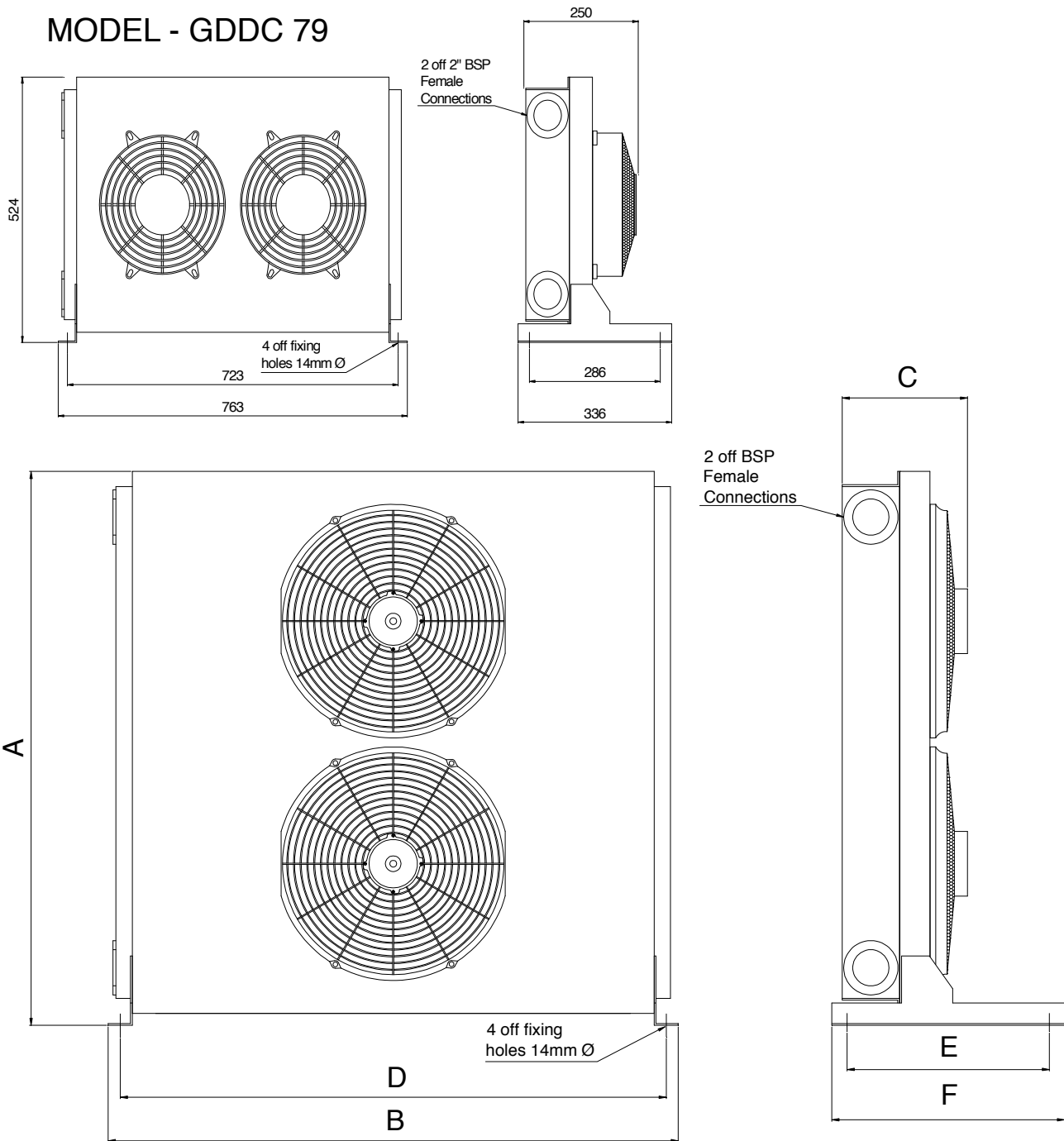

Cooler Model
GDDC 117
GDDC 120
GDDC 156
GDDC 165

A	B	C	D	E	F	Connection Size
804	846	295	806	286	336	2" BSP
918	946	210	906	286	336	2" BSP
1018	1046	235	1006	286	336	2" BSP
1085	1046	285	1106	286	336	2" BSP