

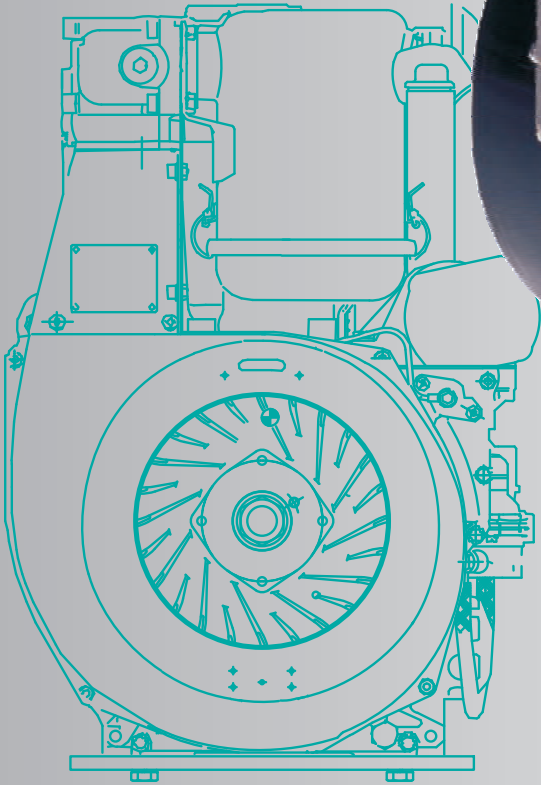

G-series

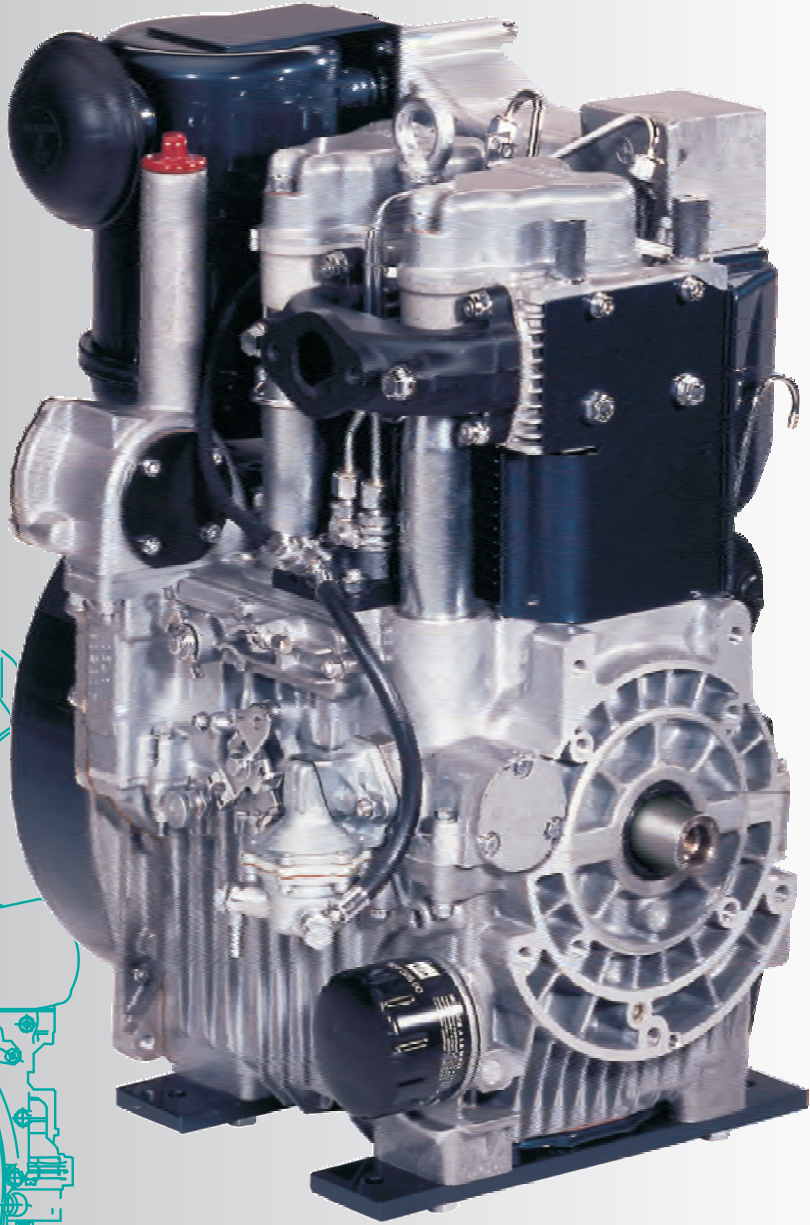

2G40 • 7.4 - 17.0 kW

THE 2-CYLINDER POWER PACKAGE

2G40

DESIGN

- Aircooled single-cylinder four stroke Diesel engines.
- Vertical cylinder.
- Crankcase in light alloy, diecast. Cylinder of grey cast iron.
- Cylinder head in light alloy.
- Crankshaft and big end in plain bearings.
- Direct injection, multi-hole nozzle.
- Value control by rocker, push-rods, tappets and camshaft.
- Pressure lubrication, with gear-type oil pump. On request, full-flow oil filter.
- Oil sump of sheet metal.
- Flywheel fan, charging alternator integrated into flywheel. No V-belt necessary.

CHARACTERISTICS

- Denoised: emission of noise reduced to the absolute minimum by means of design features and precision manufacture.
- Low fuel consumption.
- Favourable exhaust gas values – EPA / CARB certified.
- Robust: long life engine.
- Extensive interchangeability of parts within the engine family **D**.
- Reliable: no V-belts.
- Easy to service: automatic injection pump bleeding.
- Friendly to the environment: crankcase breather leads into the intake port.
- Reliable, effortless starting thanks to automatic extra fuel device.

EXHAUST REDUCED TYPES
ON REQUEST

EPA TIER IV
CARB TIER IV
ECE R-24
ARAI - Indien

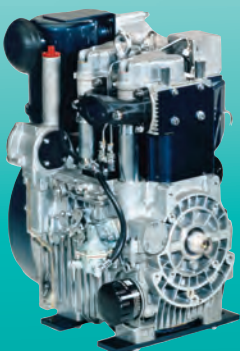

ADDITIONAL EQUIPMENT

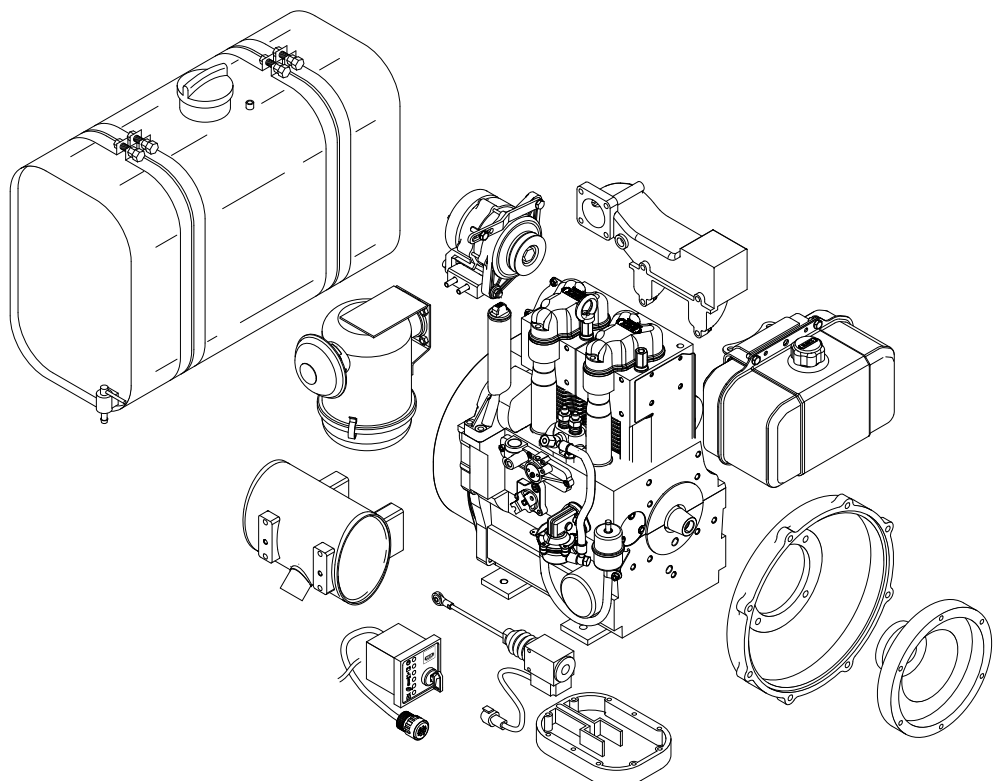

TECHNICAL DATA

2G40

▶ Number of cylinders		2
▶ Bore x stroke	mm	92 x 75
	inches	3.62 x 2.95
▶ Displacement	l	0.997
	cu.in.	60.84
▶ Mean piston speed at 3000 r.p.m.	m/s	7.5
	ft/min	1476
▶ Compression ratio		20.5
▶ Lub. oil consumption, related to full load		approx. 1% of fuel consumption, related to full load
▶ Lub. oil capacity max. / min.	l	2.5 / 1.67
	US qts	2.643 / 1.765
▶ Speed control	Idle speed	approx. 1000 r.p.m.
	static speed droop	approx. 5% at 3000 r.p.m.

TORQUE

— = at F-power according to DIN ISO 1585

- - - = at B-power according to ISO 3046-1

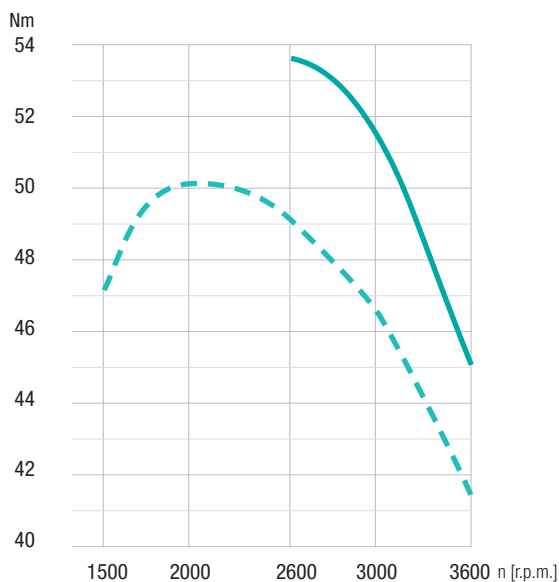

▶ Performance data refer to Standard Reference Conditions of ISO 3046-1: + 25 °C (77 °F), 100 kPa, relative humidity 30 %. During running-in period the output increases by approx. 5 % which is taken into consideration at delivery.

Power reduction acc. to ISO 3046-1.

Standard values:

Above 100 m ALT approx. 1 % per 100 m.
Above 25 °C (77 °F) approx. 4 % per 10 °C (50 °F).

The power taken from charging alternator also has to be added to the demand of power.

SPECIFIC FUEL CONSUMPTION

— = at F-power according to DIN ISO 1585

- - - = at B-power according to ISO 3046-1

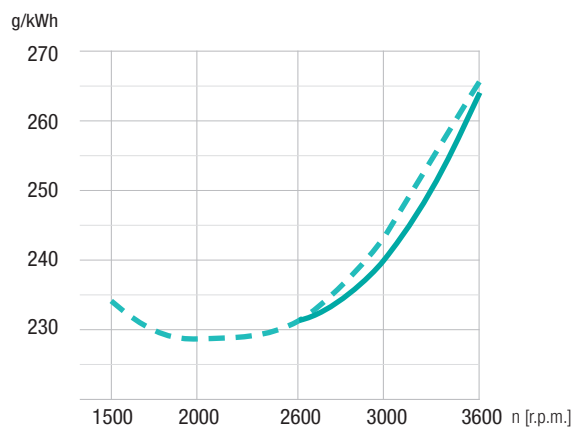

INSTALLATION DATA

2G40

▶ Combustion air required at 3000 r.p.m. approx. ¹⁾	m ³ / min	1.42
	cu.ft./min	50.3
▶ Cooling air required at 3000 r.p.m. approx. ¹⁾	m ³ / min	10.5
	cu.ft./min	370
▶ Moment of inertia	kgm ²	0.16
	lb.ft ²	3.78
▶ Starter		12 V - 2.0 kW — 24 V - 3.0 kW
▶ Alternator charging current at 3000 / 1500 r.p.m.	3000 min ⁻¹	14 V – 23 A, 28 V – 12 A, 14 V – 55 A, 28 V – 27 A
	1500 min ⁻¹	14 V – 10 A, 28 V – 5 A, 14 V – 55 A, 28 V – 27 A
▶ Battery capacity	min / max Ah	12 V / 45 / 88 Ah, 24 V / 45 / 88 Ah

¹⁾ For other r.p.m. there is a linear reduction in the air requirement

PERMISSIBLE LOAD ON POWER-TAKE-OFF POINTS

Max. permissible radial load

$$F1 = \frac{261\,000}{L1 \text{ (mm)}} \text{ (N)*}$$

$$F2 = \frac{293\,000}{L2 \text{ (mm)}} \text{ (N)*}$$

*) If belt tension is upwards, valves reduced to approx. 55 %.

Max. permissible axial force:

$$FA = 3400 \text{ N}$$

Transmissible torque:

A: 100 %

B: 100 %

C: 30.6 Nm

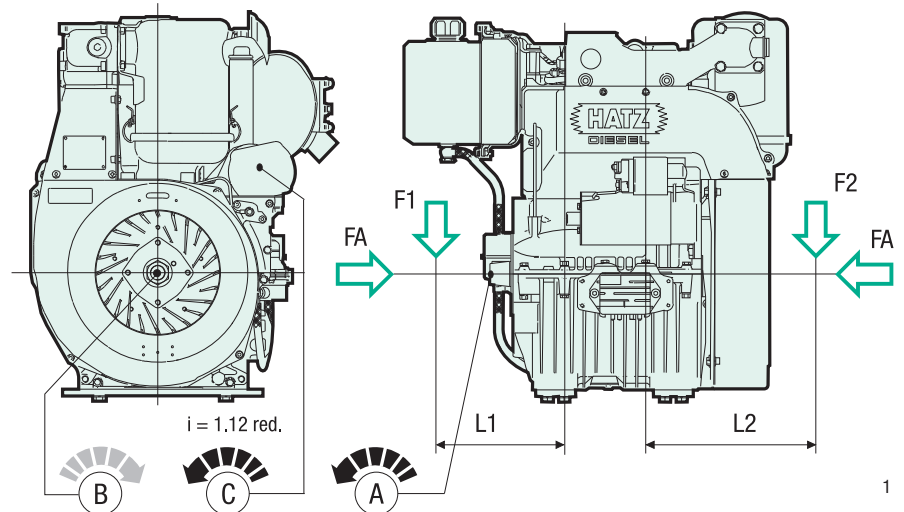

MAINTENANCE AND OPERATING POINTS

For the engine to achieve its maximum life, it is essential for it to be serviced meticulously at regular intervals.

The better the accessibility, the more promptly and conscientiously the engine will be maintained.

Please convince yourself personally that all service and operation points are easily accessible before delivering your machine to the customer.

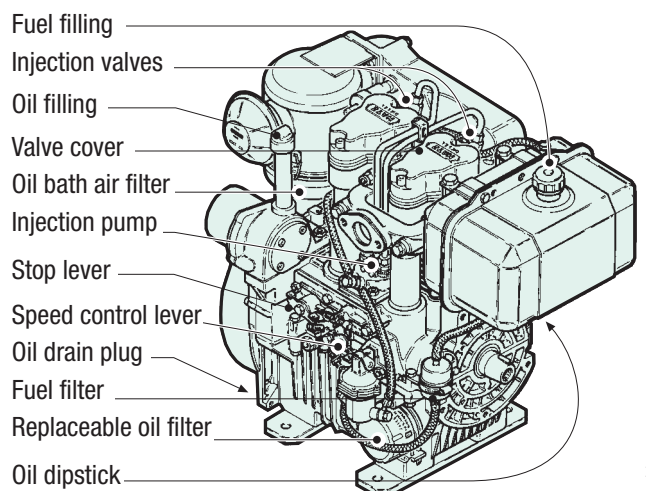

ELECTRICAL EQUIPMENT

The engine-mounted components, such as starter, alternator and switches, are connected to the instrument box by means of a 2 m cable harness. The engine is started and controlled from this instrument box. Instrument box and cable harness are part of the additional equipment and supplied according to the number of electrical safety features which are required. If the engine has to

be started at temperatures below - 7 °C, it must be equipped with a preheating system (glow plug) (additional equipment). Further additional equipment includes automatic start and stop, remote control etc.

Please ask for drawings and wiring diagrams.

www.hatz-diesel.com

POWER-TAKE-OFF AND SENSE OF ROTATION

- Main power-take-off with engine speed at opposite side of flywheel (fig. 3).
- Power-take-off at flywheel with engine speed (fig. 4).

ENGINE VARIANTS

- Rope start (fig. 5).
 - Electric start 12 V (fig. 6).
 - Electric start 24 V (fig. 6).
 - Electric start 12 V (fig. 7).
 - Electric start 24 V (fig. 7).
- flangeable at main p.t.o. side opposite flywheel either directly or using adaptor housing SAE 5.

WEIGHT incl. tank, air filter, and exhaust silencer

	Rope start	Electric start 12 V, flywheel-alternator 20A	Electric start 24 V, flywheel-alternator 8A	Electric start 12 V, belt driven alternator 55A	Electric start 24 V, belt driven alternator 27A
kg	88.8	96.8	99.1	103.4	105.2
lbs.	195.8	213.4	218.5	228.0	232.0

MOUNTING OF ENGINE

For engine speeds above 2300 - 2500 r.p.m. it is recommended to use flexible mounts. On request we recommend suitable rubber mounts.

Please inform us:

- weight of unit to be supported
- position of gravity center
- selected speed

SCOPE OF DELIVERY OF ENGINE IN STANDARD EQUIPMENT

Engine completely assembled and tested for full load. Equipped with speed control, operated via Bowden cable, automatic cold start device, automatic injection pump bleeding, eye-hook for transport (capability for engine only). Sheet metal parts black lacquered. Engine without oil.

Additional equipment: Gaskets for 1st maintenance

ADDITIONAL EQUIPMENT

Thanks to the complete programme of additional equipment every engine can be adapted to the special requirements of every application. As a minimum, every engine needs the "additional equipment, necessary for operation".

You find out details at our HATZ-contracting partners.

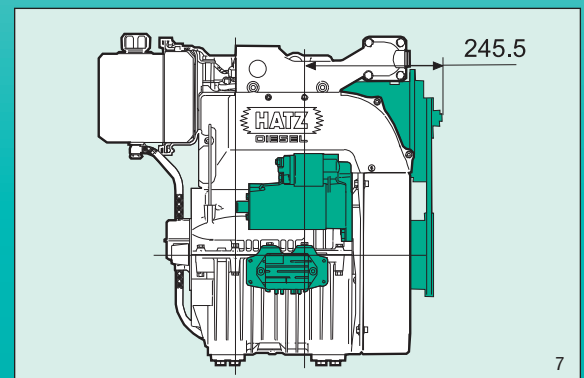
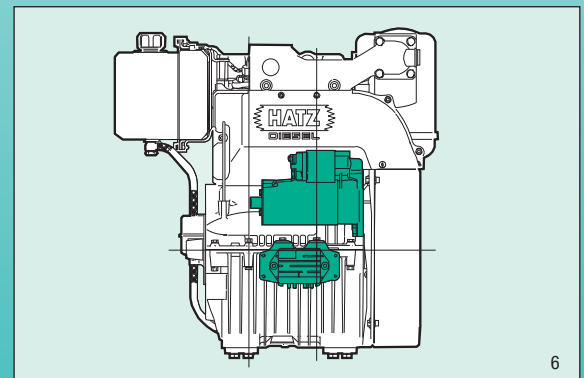
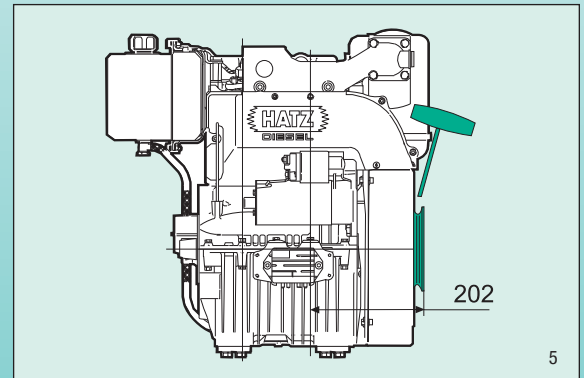
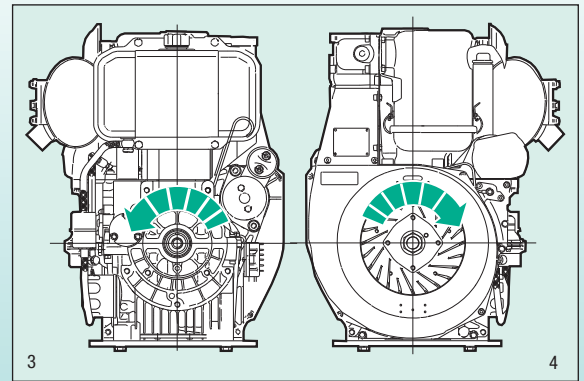

PERFORMANCE TABLE
2G40

Norm	Hatz-Spec.	r.p.m.	kW*	HP*
▶ Vehicle output acc. to DIN ISO 1585.	NF	3600	17.0	23.1
		3000	16.2	22.0
		2600	14.6	19.9
▶ ISO net brake fuel stop power (IFN) for strong intermittent load acc. to ISO 3046-1.	NB _{Si}	3600	16.3	22.2
		3000	15.5	21.1
		2600	13.9	18.9
▶ ISO net brake fuel stop power (IFN) for intermittent load acc. to ISO 3046-1.	NB	3600	15.6	21.2
		3000	14.7	20.0
		2600	13.4	18.2
		2300	12.0	16.3
		2000	10.5	14.3
		1800	9.3	12.6
		1500	7.4	10.1
▶ ISO-standard power (ICXN) (10% overload permissible) ▶ ISO-standard fuel stop power (no overload permissible) acc. to ISO 3046-1. For constant speed and constant load (ICFN).	NS (NA)	3000	13.7	18.6
		2500	12.3	16.7

* Performance specifications without exhaust certificates. Performance tables with exhaust certificates upon request.

2G40

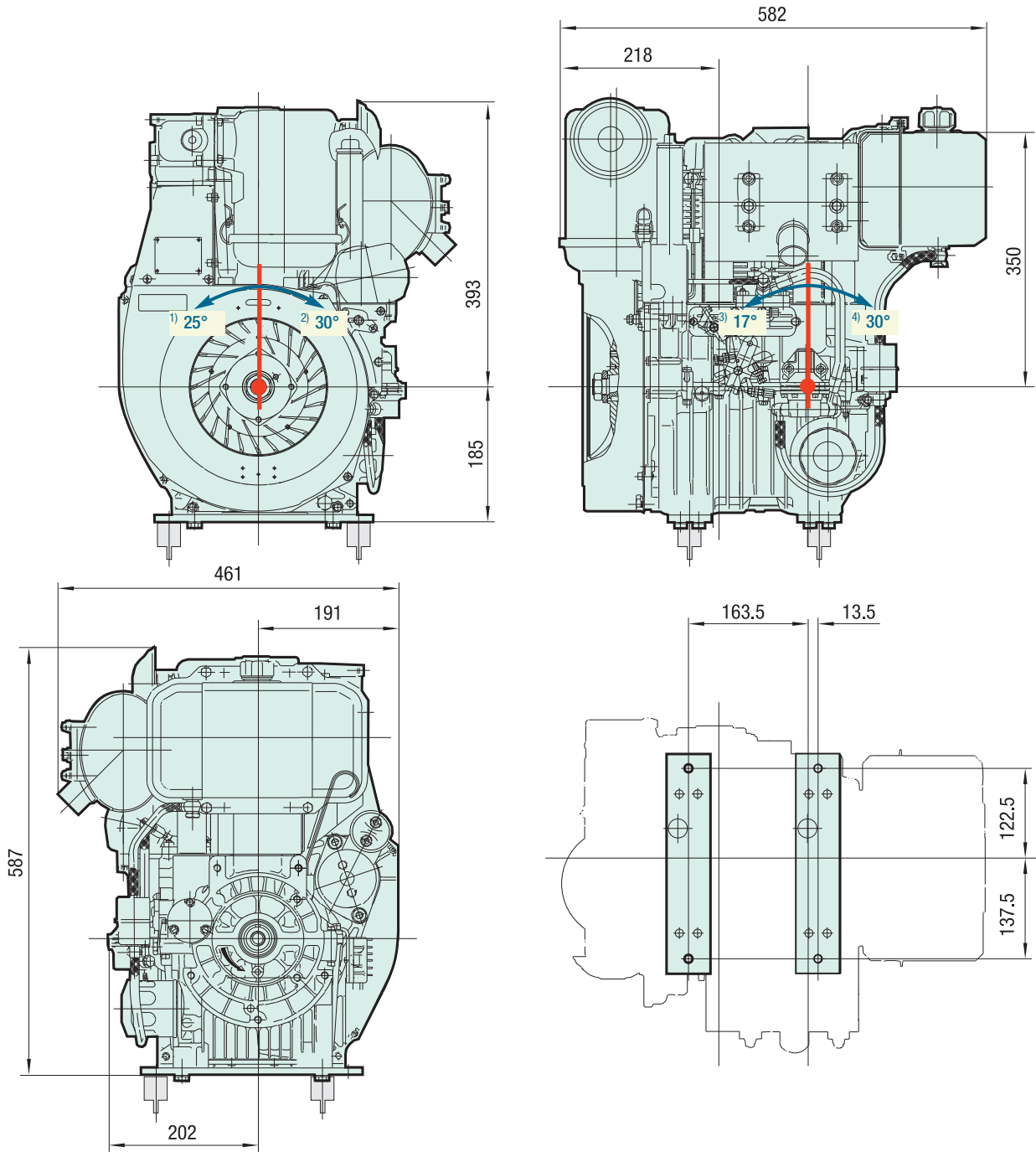

*) max. permanent tilting

1) Flywheel up 2) Flywheel down 3) Oilfilter up 4) Oilfilter down

► Drawings with detailed - and connection measures can either be demanded or downloaded as pdf- resp. dxf-file which are shown in the Internet.

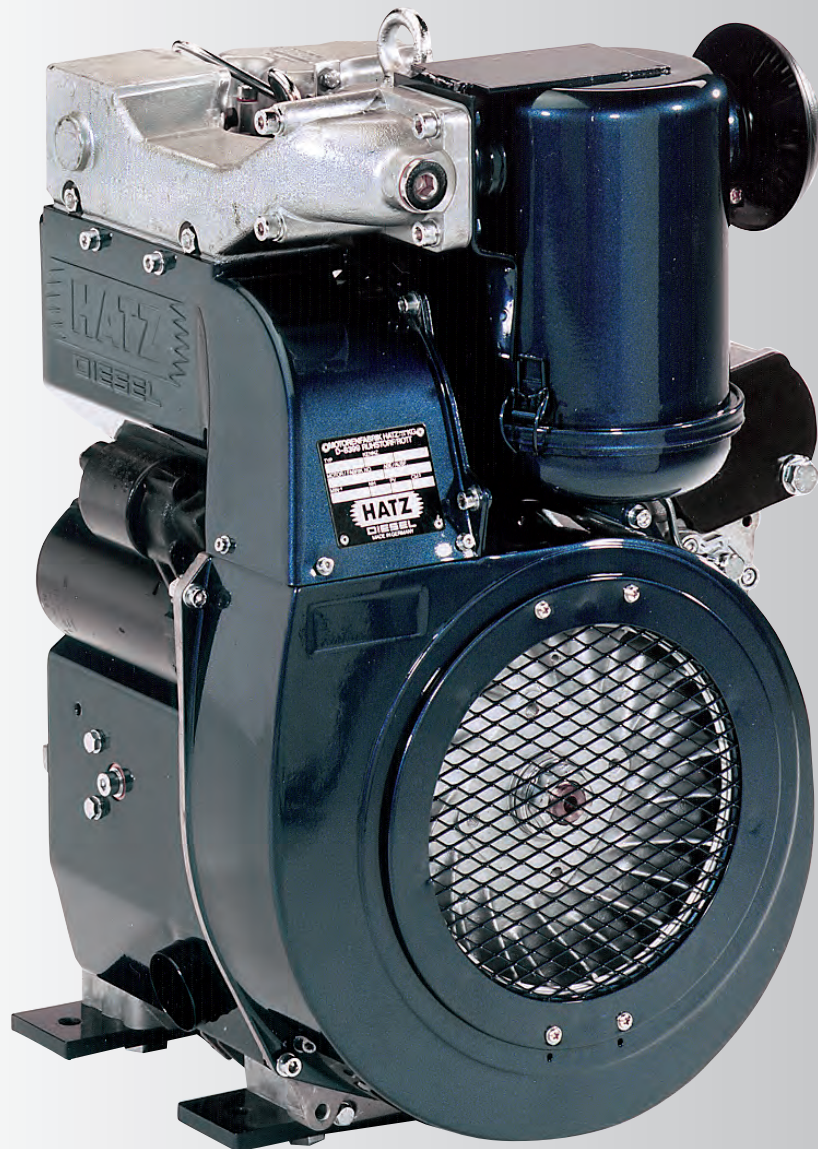

**MOTORENFABRIK HATZ
GMBH & CO. KG**
Ernst-Hatz-Straße 16
94099 Ruhstorf
GERMANY

Telephone: +49 8531 319-0
Telefax: +49 8531 319-418
marketing@hatz-diesel.de

www.hatz-diesel.com



5 / 700 384 76 - ENG - 05.10 - 1 Printed in Germany
Modifications, which serve the technical improvements, are reserved.