

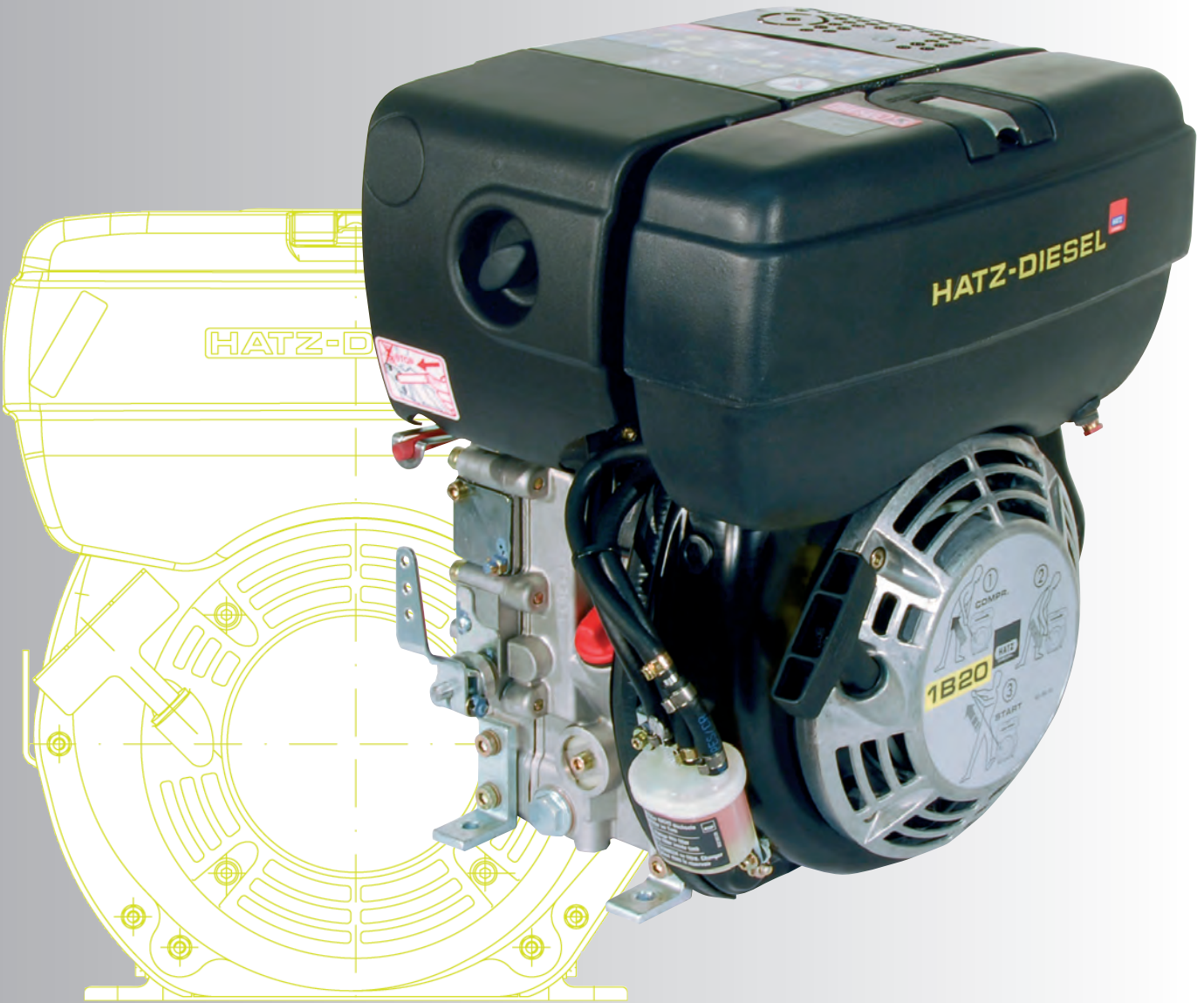

B-series



1B20 • 1.4-3.5 kW **1B27** • 1.6-4.0 kW **1B30** • 2.1-5.4 kW
1B40 • 3.2-7.5 kW **1B50** • 3.5-8.0 kW

THE CHALLENGERS:

REVOLUTIONARY TECHNIQUE FOR SINGLE-CYLINDER DIESEL ENGINES

1B20 • 1B27 • 1B30 • 1B40 • 1B50

DESIGN

- Air-cooled single-cylinder 4-stroke Diesel engine.
- Vertical cylinder.
- Light alloy diecast cylinder crankcase.
- Light alloy cylinder head.
- Forged crankshaft.
- Light alloy piston for low free forces of gravity.
- Lubrication by pressurised circulation of oil, fine screen filtering in main flow.
- Valve control by rocker, push-rods and tappets.

CHARACTERISTICS

- Direct injection.
- Compression from 1:21 to 1:22. Good cold start performance.
- Fuel orientated mixture preparation. Result: excellent exhaust quality. EPA/CARB.
- Speed regulation by spring-loaded governor.
Proportionality < 5% at 3000 / 3600 r.p.m.
- The control cover houses the governor, the entire valve drive, the injector pump drive and the automatic decompression system and oil pump.
- Oil drain on both (narrow) sides of the engine. This gives free access of at least one drain position for almost all installations.
- Dry air filter with paper cartridge and integrated pre-cleaner.
- Cooling fan and AC generator incorporated in the flywheel (not sensitive to dust).
- 4 separate engine feet permit mounting on uneven foundations.
Differences of level of up to 1 mm can be corrected.
- Exhaust outlet flexible as regards both position and direction of exit.

EXHAUST REDUCED TYPES
ON REQUEST

EPA TIER IV
CARB TIER IV



ADDITIONAL EQUIPMENT

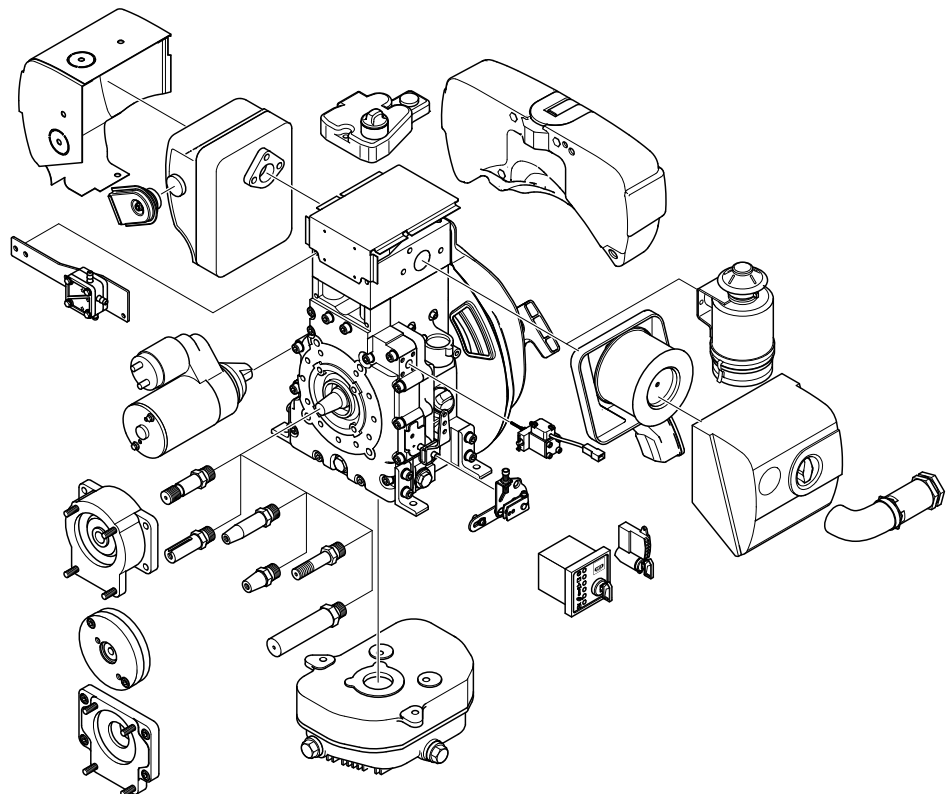

TECHNICAL DATA		1B20	1B27	1B30	1B40	1B50
▶ Number of cylinders		1	1	1	1	1
▶ Bore x stroke	mm	69 x 65	74 x 65	80 x 69	88 x 76	93 x 76
	inches	2.72 x 2.56	2.91 x 2.56	3.15 x 2.72	3.46 x 2.99	3.66 x 2.99
▶ Displacement	l	0.243	0.280	0.347	0.462	0.517
	cu.in.	14.82	17.09	21.18	28.19	31.55
▶ Mean piston speed at 3000 r.p.m.	m/s	6.5	6.5	6.9	7.6	7.6
	ft/min	1280	1280	1358	1496	1496
▶ Compression ratio		22	21.5	21.5	20.5	20.5
▶ Lub. oil consumption, related to full load		max. 1 % of fuel consumption				
▶ Lub. oil capacity max. / min.	l	0.9 / 0.4	0.9 / 0.4	1.1 / 0.6	1.5 / 0.7	1.5 / 0.7
	US qts	0.95 / 0.42	0.95 / 0.42	1.16 / 0.63	1.59 / 0.74	1.59 / 0.74
▶ Speed control	Idle speed	approx. 1000 r.p.m.				approx. 800 r.p.m.
	static speed droop	approx. 5% at 3000 r.p.m.				

TORQUE AT MAXIMUM POWER

— = at F-power according to DIN ISO 1585

- - - = at B-power according to ISO 3046-1

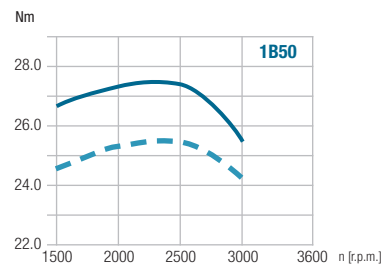
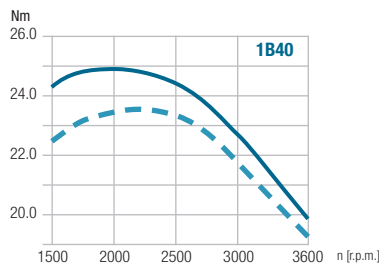
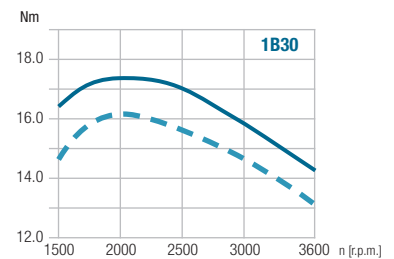
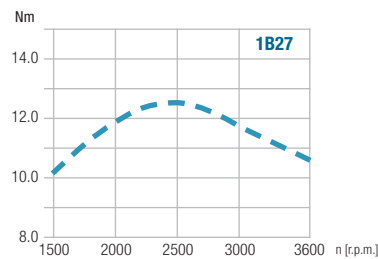
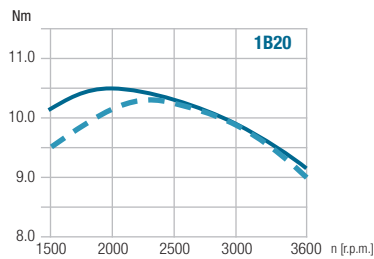

SPECIFIC FUEL CONSUMPTION AT MAXIMUM POWER

— = at F-power according to DIN ISO 1585

- - - = at B-power according to ISO 3046-1

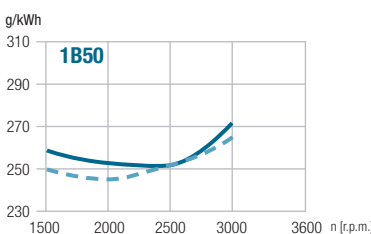
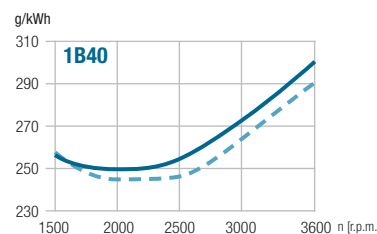
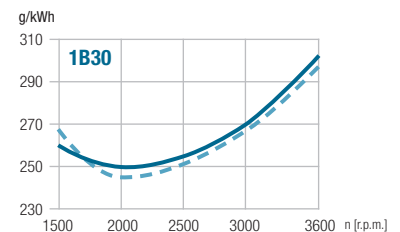
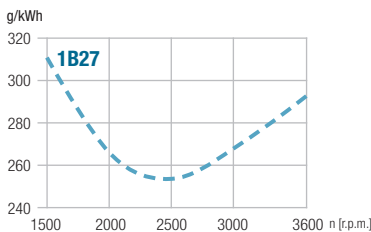
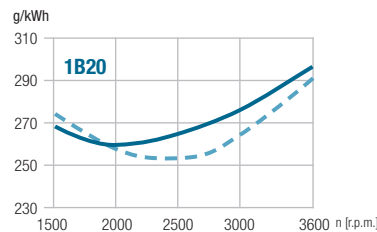

▶ Performance data refer to Standard Reference Conditions of ISO 3046-1:
+ 25 °C (77 °F), 100 kPa, relative humidity 30 %.
During running-in period the output increases by approx. 5 % which is taken into consideration at delivery.
Power reduction acc. to ISO 3046-1.
Standard values: Above 100 m ALT approx. 1 % per 100 m.
Above 25 °C (77 °F) approx. 4 % per 10 °C (50 °F).
The power taken from charging alternator also has to be added to the demand of power.

INSTALLATION DATA		1B20	1B27	1B30	1B40	1B50
▶ Combustion air required at 3000 r.p.m. approx. ¹⁾	m ³ / min	0.35	0.42	0.52	0.69	0.78
	cu.ft./min	12	15	18	24	28
▶ Cooling air required at 3000 r.p.m. approx. ¹⁾	m ³ / min	4.2	4.2	6.0	7.3	7.6
	cu.ft./min	148	148	212	257	268
▶ Starter		12 V - 1.0 kW – 24 V - 1.6 kW				
▶ Alternator charging current at 3000 / 1500 r.p.m.		14 V - 14 A / 7 A – 28 V - 10 A / 5 A				
▶ Battery capacity	min / max Ah	12 V - 36 / 60 Ah – 24 V - 24 / 44 Ah				

¹⁾For other r.p.m. there is a linear reduction in the air requirements

PERMISSIBLE LOAD ON POWER-TAKE-OFF POINTS

1B20 / 1B27 / 1B30

max. permissible radial force

$$F1 = \frac{60\,000}{L \text{ (mm)} - 70} \text{ (N)}$$

max. permissible axial force

$$F2 = 800 \text{ (N)}$$

1B40 / 1B50

max. permissible radial force

$$F1 = \frac{62\,600}{L \text{ (mm)} - 84} \text{ (N)}$$

max. permissible axial force

$$F2 = 1200 \text{ (N)}$$

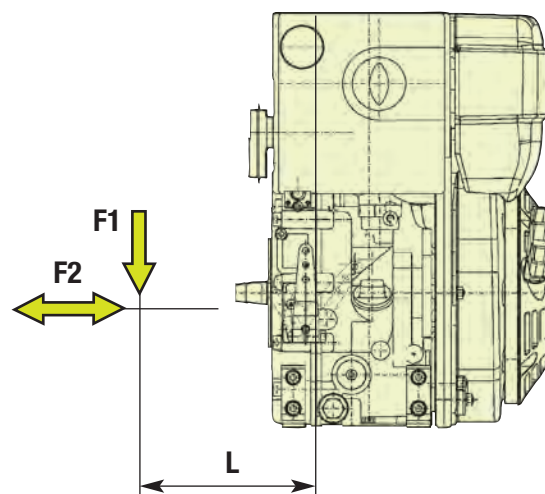

1

MAINTENANCE AND OPERATING POINTS

To achieve the engines maximum life, it is essential that the engine gets serviced meticulously at regular intervals.

During your first installation please make sure that easy accessibility of service and operating points is assured.

The easier the accessibility is, the sooner and more conscientious the engine will be maintained.

Please convince yourself personally that all service and operation points are easily accessible before delivering your machine to the customer.

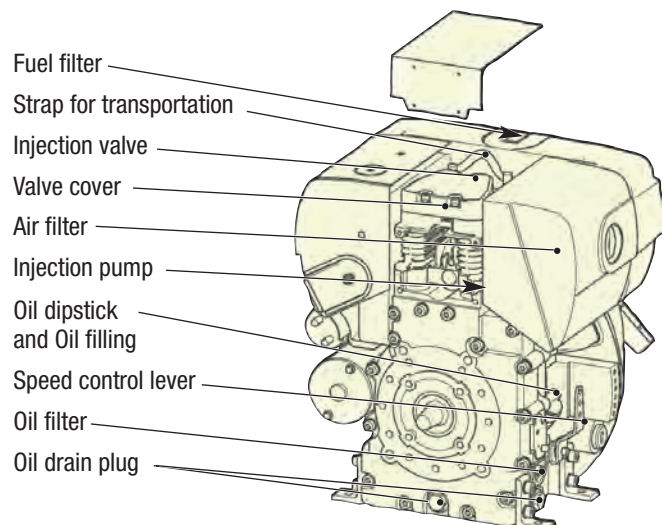

2

ELECTRICAL EQUIPMENT

Starter-switchboard-instruments incl. LED-display are mounted to the engine or will be delivered upon request as switchboard-instruments with cable (2m) loose. The engine is started and controlled from this instrument box. Instrument box and cable harness are part of the additional equipment and supplied according to the number of electrical safety features which are required. If the engine has to be

started at temperatures below - 10 °C, engine must be fitted with a pre-heating system (glow plug) (additional equipment). Further additional equipments include automatic start and stop, remote control etc.

Please ask for drawings and wiring diagrams.

www.hatz-diesel.com

POWER-TAKE-OFF AND SENSE OF ROTATION

- Power-take-off shaft, governor side, with max. engine speed, Sense of rotation anti-clockwise (fig. 3).
- Different stub-shafts (page 6).
- at thread assembled shafts $J_{max} = 0.04 \text{ kgm}^2$
- Radial loading capacity, see picture 1.
- Hydraulic pump mounting as very short-mounted add. equipment.

ENGINE MODELS

- **Version 1B20 / 27** :1500 r.p.m. bis 3600 r.p.m.
- **Version 1B30** :1500 r.p.m. bis 3600 r.p.m.
- **Version 1B40T** :1500 r.p.m. bis 3600 r.p.m.
- **Version 1B40U** :1500 r.p.m. bis 3600 r.p.m.
- **Version 1B50T** :1500 r.p.m. bis 3000 r.p.m.
- **Version 1B50U** :1500 r.p.m. bis 3000 r.p.m.

U: with additional counter balance
T: without additional counter balance

ENGINE VARIANTS

- Engine with Recoil-start on flywheel side (fig 4).
- Engine with electric start 12 V or 24 V and Recoil-start (fig. 5).

WEIGHT incl. tank, air filter, and exhaust silencer

	1B20		1B27		1B30		1B40		1B50	
	kg	lbs.	kg	lbs.	kg	lbs.	kg	lbs.	kg	lbs.
Engine with Recoil-start	28.0	61.7	29.0	63.9	35.0	77.1	48.0	105.8	51.2	112.9
Electric start 12 V or 24 V	32.8	72.2	33.8	74.5	37.8	83.3	53.3	117.5	56.5	124.6

SCOPE OF DELIVERY OF ENGINE IN STANDARD EQUIPMENT

Engine tested for full load on test bench. Engine fitted with blower fan, variable speed governor, lubricating oilfilter, dry-type airfilter or oil-bath airfilter, automatic decompression system, automatic injection pump bleeding, filling device for start oil, strap for transportation (only suitable to carry the engine weight).

Light metal housing not painted. Sheet metal parts painted.

Engine without oil.

Accessories: Gaskets for 1st maintenance

ADDITIONAL EQUIPMENT

Thanks to the complete programme of additional equipment every engine can be adapted to the special requirements of every application. As a minimum, every engine needs the "additional equipment, necessary for operation".

You find out details at our HATZ-contracting partners.

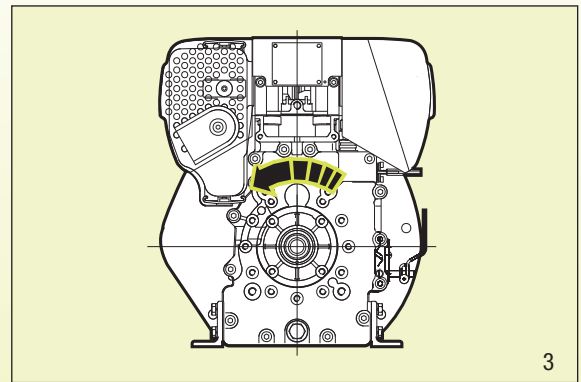

3

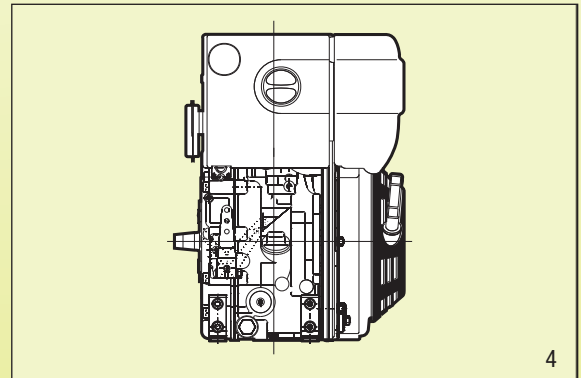

4

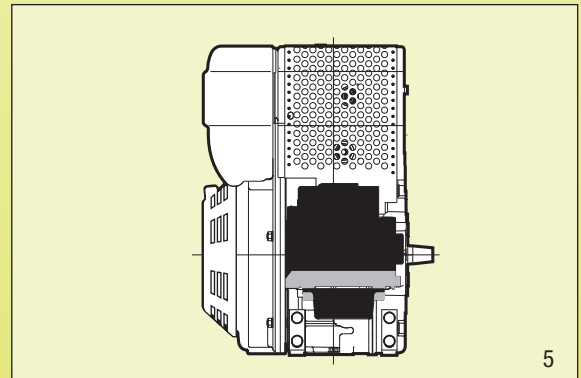





5

PERFORMANCE TABLE			1B20		1B27		1B30		1B40		1B50	
Norm	Hatz-Spec.	r.p.m.	kW*	HP*	kW*	HP*	kW*	HP*	kW*	HP*	kW*	HP*
▶ Vehicle output acc. to DIN ISO 1585.	NF	3600	3.5	4.8	—	—	5.4	7.3	7.5	10.2	—	—
		3000	3.1	4.2	—	—	5.0	6.8	7.1	9.7	8.0	10.9
		2600	2.8	3.8	—	—	4.6	6.3	6.6	9.0	7.4	10.1
		2300	2.5	3.4	—	—	4.1	5.6	6.0	8.2	6.6	9.0
		2000	2.2	3.0	—	—	3.6	4.9	5.2	7.2	5.7	7.8
		1800	1.9	2.6	—	—	3.3	4.5	4.6	6.3	5.1	6.9
		1500	1.6	2.2	—	—	2.6	3.5	3.8	5.2	4.2	5.7
▶ ISO net brake fuel stop power (IFN) for strong intermittent load acc. to ISO 3046-1.	NB	3600	3.4	4.6	4.0	5.4	5.0	6.8	7.3	9.9	—	—
		3000	3.1	4.2	3.7	5.0	4.6	6.3	6.8	9.2	7.6	10.3
		2600	2.8	3.8	3.4	4.6	4.2	5.7	6.3	8.6	6.9	9.4
		2300	2.5	3.4	3.0	4.1	3.9	5.3	5.7	7.8	6.2	8.4
		2000	2.1	2.9	2.5	3.4	3.4	4.6	4.9	6.7	5.3	7.2
		1800	1.9	2.6	2.2	3.0	3.0	4.1	4.4	6.0	4.7	6.4
		1500	1.5	2.0	1.6	2.2	2.3	3.1	3.5	4.8	3.9	5.3
▶ ISO-standard power (ICXN) (10% overload permissible) ▶ ISO-standard fuel stop power (no overload permissible) acc. to ISO 3046-1. For constant speed and constant load (ICFN).	NS (NA)	3600	3.1	4.2	—	—	4.5	6.1	6.5	8.8	—	—
		3000	2.8	3.8	—	—	4.2	5.7	6.1	8.3	6.8	9.2
		2600	2.5	3.4	—	—	3.8	5.2	5.6	7.6	6.2	8.4
		2300	2.2	3.0	—	—	3.5	4.8	5.1	6.9	5.5	7.5
		2000	1.9	2.6	—	—	3.1	4.2	4.4	6.0	4.8	6.5
		1800	1.7	2.3	—	—	2.7	3.7	3.9	5.3	4.2	5.7
		1500	1.4	1.9	—	—	2.1	2.9	3.2	4.4	3.5	4.8

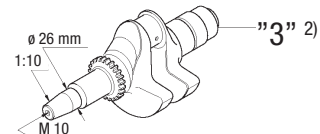
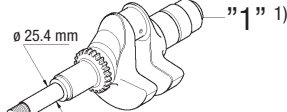
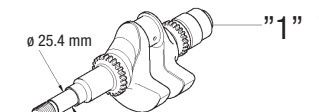
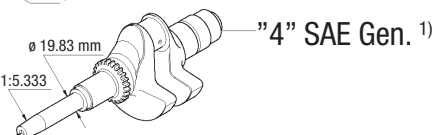
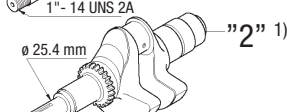
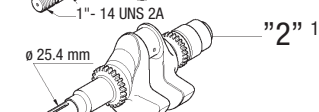
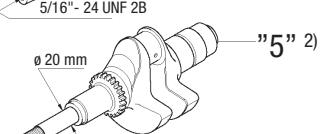
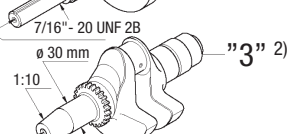
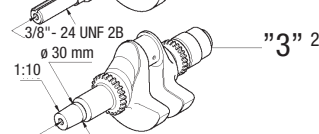
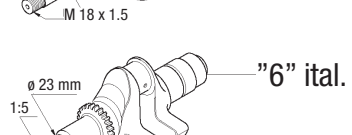
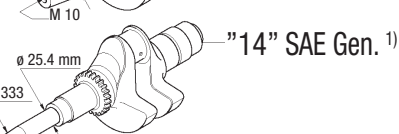
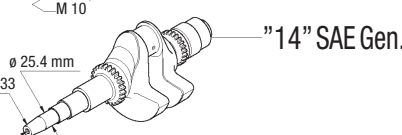
* Performance specifications without exhaust certificates. Performance tables with exhaust certificates upon request.

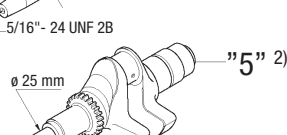
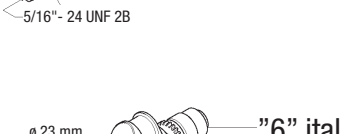
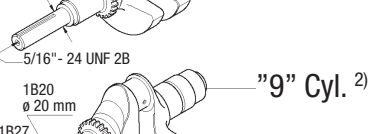
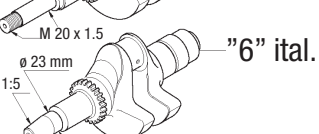
SELECTION OF AVAILABLE SHAFT FORMS ¹⁾ according to SAE J 609 ²⁾ according to LEMA LES 1203-1991

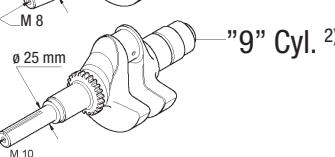
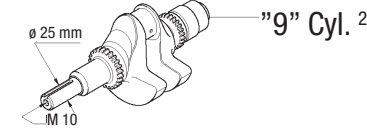
1B20 / 1B27	1B30	1B40 / 1B50
 "3" ²⁾	 "1" ¹⁾	 "1" ¹⁾
 "4" SAE Gen. ¹⁾	 "2" ¹⁾	 "2" ¹⁾
 "5" ²⁾	 "3" ²⁾	 "3" ²⁾
 "6" ital.	 "14" SAE Gen. ¹⁾	 "14" SAE Gen. ¹⁾
 "7" Cyl. 3/4" ¹⁾	 "5" ²⁾	 "6" ital.
 "9" Cyl. ²⁾	 "6" ital.	 "9" Cyl. ²⁾
 "9" Cyl. ²⁾	 "9" Cyl. ²⁾	 "9" Cyl. ²⁾

DIMENSIONS

Spread at outlines ± 3 mm due to tolerance.

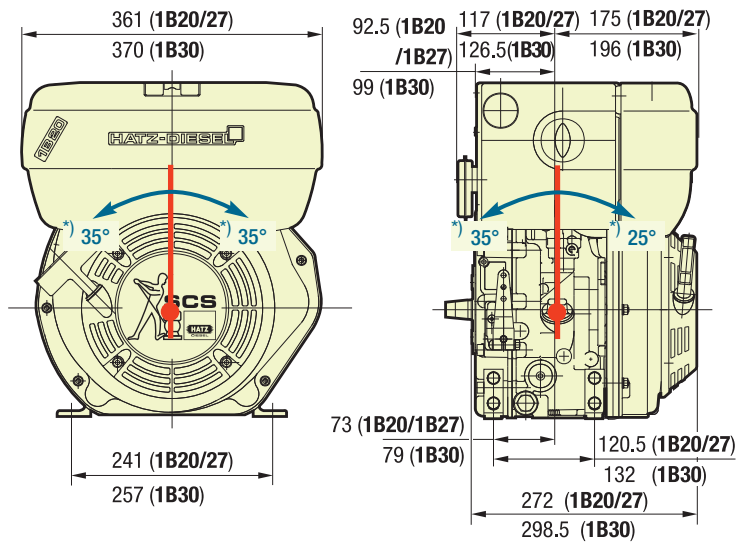

1B20 / 1B27 / 1B30

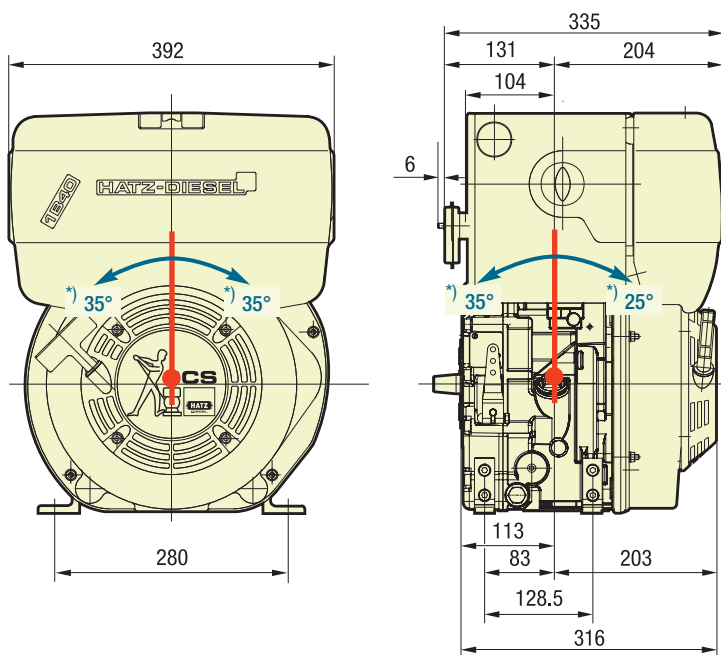
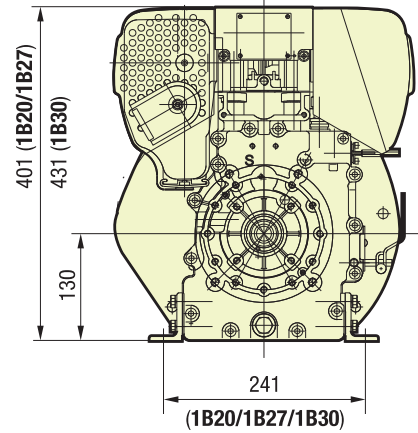

1B40

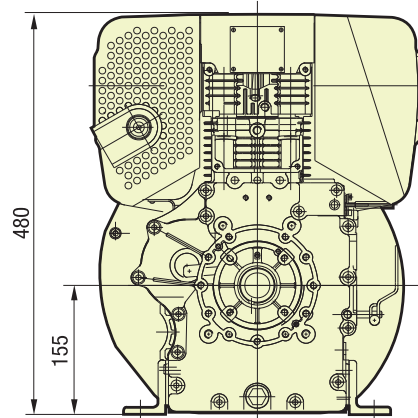

► Drawings with detailed - and connection measures can either be demanded or downloaded as pdf- resp. dxf-file which are shown in the Internet.

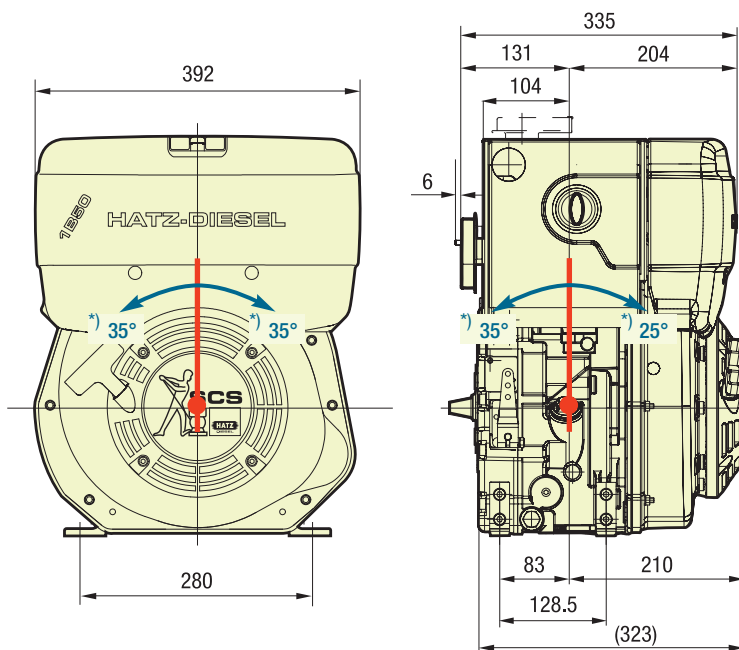

1B50

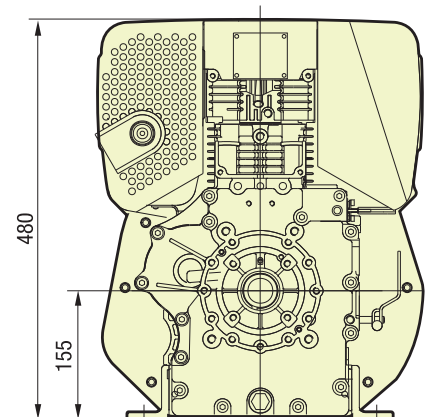

*) max. permanent tilting

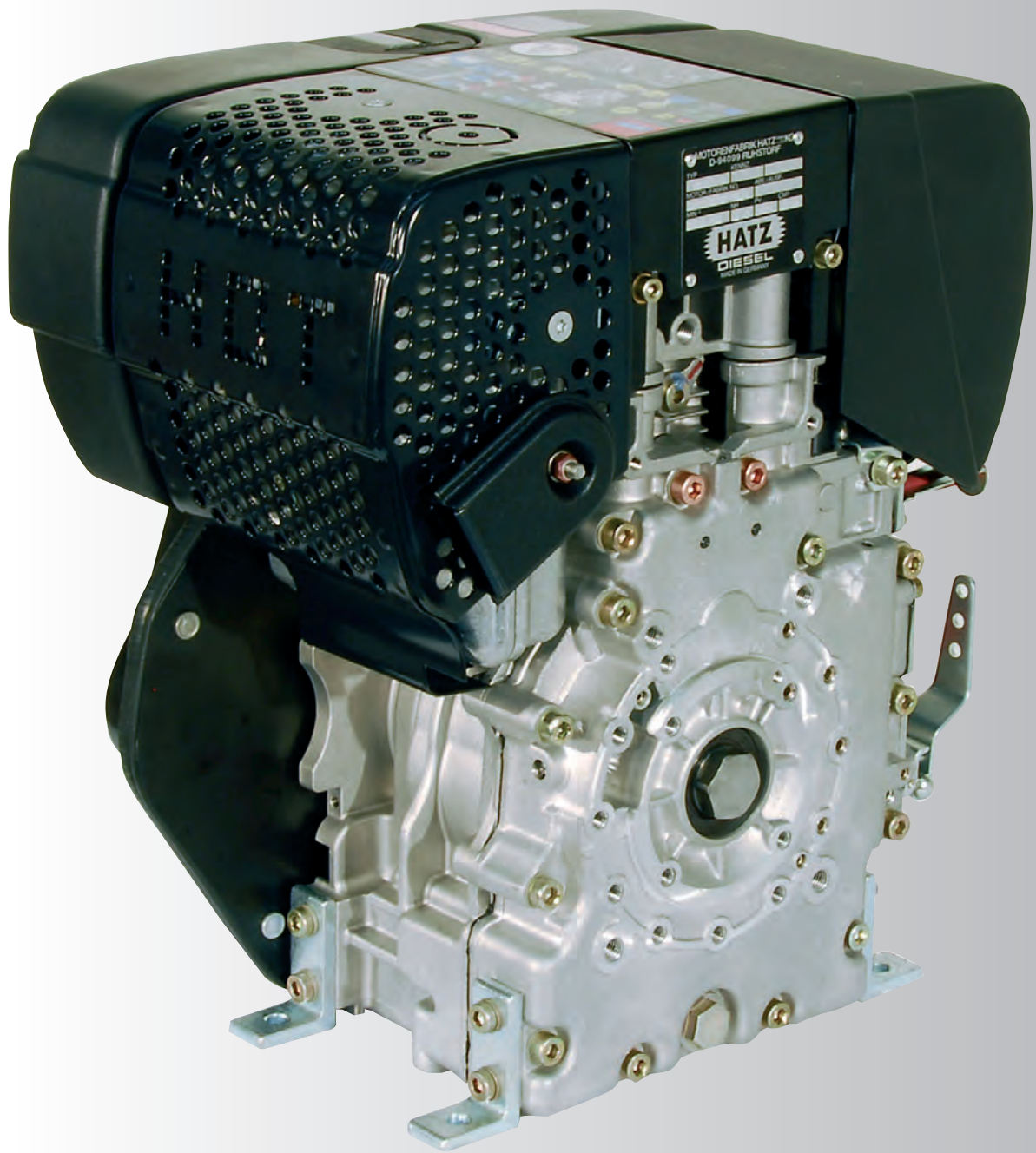

**MOTORENFABRIK HATZ
GMBH & CO. KG**
Ernst-Hatz-Straße 16
94099 Ruhstorf
GERMANY

Telephone: +49 8531 319-0
Telefax: +49 8531 319-418
marketing@hatz-diesel.de

www.hatz-diesel.com

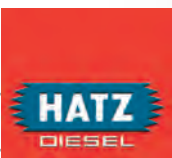

700 383 56 - ENG - 06.10 - Printed in Germany
Modifications, which serve the technical improvements, are reserved.