

HYDRAULIC MOTORS EPMT

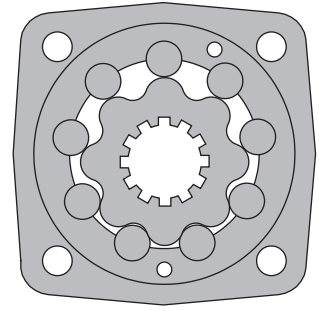

APPLICATION

- » Conveyors;
- » Metal working machines;
- » Machines for agriculture;
- » Road building machines;
- » Mining machinery;
- » Food industries;
- » Special vehicles;
- » Plastic and rubber machinery etc.



CONTENTS

Specification data	87
Function diagrams	88÷90
Dimensions and mounting	91
Shaft extensions	92
Dimensions and mounting- EPMTS, V	93÷94
Internal Spline data	95
Permissible shaft loads	95
Tacho connection	96
Order code	96

OPTIONS

- » Model- Disc valve, geroler;
- » Flange with wheel mount;
- » Short motor;
- » Tacho connection;
- » Side and rear ports
- » Shafts- straight, splined and tapered;
- » Metric and BSPP ports;
- » Other special features.

GENERAL

Displacement, [cm ³ /rev.]	161,1 ÷ 725
Max. Speed, [RPM]	625 ÷ 175
Max. Torque, [daNm]	47 ÷ 125
Max. Output, [kW]	20,2 ÷ 33,5
Max. Pressure Drop, [bar]	200 ÷ 115
Max. Oil Flow, [l/min]	100 ÷ 125
Min. Speed, [RPM]	10 ÷ 5
Permissible Shaft Loads, [daN]	$P_{rad}=1700; P_a=1000$
Pressure fluid	Mineral based- HLP(DIN 51524) or HM(ISO 6743/4)
Temperature range, [°C]	-30 ÷ 90
Optimal Viscosity range, [mm ² /s]	20 ÷ 75
Filtration	ISO code 20/16 (Min. recommended fluid filtration of 25 micron)

Oil flow in drain line

Pressure drop (bar)	Viscosity (mm ² /s)	Oil flow in drain line (l/min)
140	20	1,5
	35	1
210	20	3
	35	2

Pressure Losses

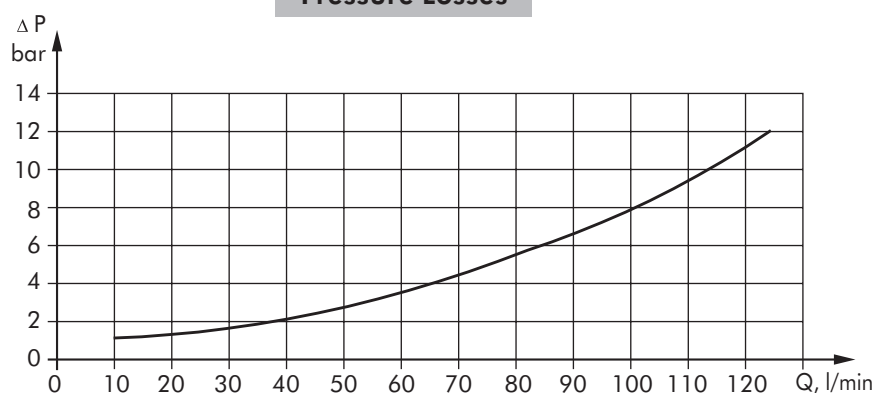

SPECIFICATION DATA

Type	EPMT 160	EPMT 200	EPMT 250	EPMT 315	EPMT 400	EPMT 500	EPMT 630	EPMT 725	
Displacement [cm ³ /rev.]	161,1	201,4	251,8	326,3	410,9	523,6	612,3	725	
Max. Speed, [RPM]	cont.	625	625	500	380	305	240	206	172
	Int.*	780	750	600	460	365	285	247	205
Max. Torque [daNm]	cont.	47	59	73	95	108	122	123	125
	Int.*	56	71	88	114	126	137	138	140
	peak**	66	82	102	133	144	160	161	165
Max. Output [kW]	cont.	26,5	33,5	33,5	33,5	30	26,5	24,3	20,2
	int.*	32	40	40	40	35	30	27,5	26,8
Max. Pressure Drop [bar]	cont.	200	200	200	200	180	160	140	115
	Int.*	240	240	240	240	210	180	160	130
	peak**	280	280	280	280	240	210	190	160
Max. Oil Flow [l/min]	cont.	100	125	125	125	125	125	125	125
	Int.*	125	150	150	150	150	150	151,4	151,4
Max. Inlet Pressure [bar]	cont.	210	210	210	210	210	210	210	210
	Int.*	250	250	250	250	250	250	250	250
	peak**	300	300	300	300	300	300	300	300
Max. Return Pressure without Drain Line or Max. Pressure in Drain Line , [bar]	cont. 0-100 RPM	75	75	75	75	75	75	75	75
	cont. 100-300 RPM	40	40	40	40	40	40	40	40
	cont. >300 RPM	20	20	20	20	20	-	-	-
Int.* 0-max. RPM	75	75	75	75	75	75	75	75	
Max. Return Pressure with Drain Line [bar]	cont.	140	140	140	140	140	140	140	140
	Int.*	175	175	175	175	175	175	175	175
	peak**	210	210	210	210	210	210	210	210
Max. Starting Pressure with Unloaded Shaft, [bar]	10	10	10	10	10	10	10	10	
Min. Starting Torque [daNm]	at max. press. drop cont.	34	43	53	74	84	95	95	95
	at max. press. drop Int.*	41	52	63	89	97	106	108	110
Min. Speed***, [RPM]	10	9	8	7	6	5	5	5	
Weight, [kg]	EPMT	20	20,5	21	22	23	24	25	26
	EPMTW	22	22,5	23	24	25	26	27	28
	EPMTS	15	15,5	16	17	18	19	20	21
	EPMTV	11	11,5	12	13	14	15	16	17

* Intermittent operation: the permissible values may occur for max. 10% of every minute.

** Peak load: the permissible values may occur for max. 1% of every minute.

*** For speeds of 5 RPM lower than given, consult factory or your regional manager.

- 1) Intermittent speed and intermittent pressure must not occur simultaneously.
- 2) Recommended filtration is per ISO cleanliness code 20/16. A nominal filtration of 25 micron or better.
- 3) Recommend using a premium quality, anti-wear type mineral based hydraulic oil, HLP(DIN51524) or HM(ISO6743/4).
If using synthetic fluids consult the factory for alternative seal materials.
- 4) Recommended minimum oil viscosity 13 mm²/s at 50°C.
- 5) Recommended maximum system operating temperature is 82°C.
- 6) To assure optimum motor life fill with fluid prior to loading and run at moderate load and speed for 10-15 minutes.

FUNCTION DIAGRAMS

EPMT 160

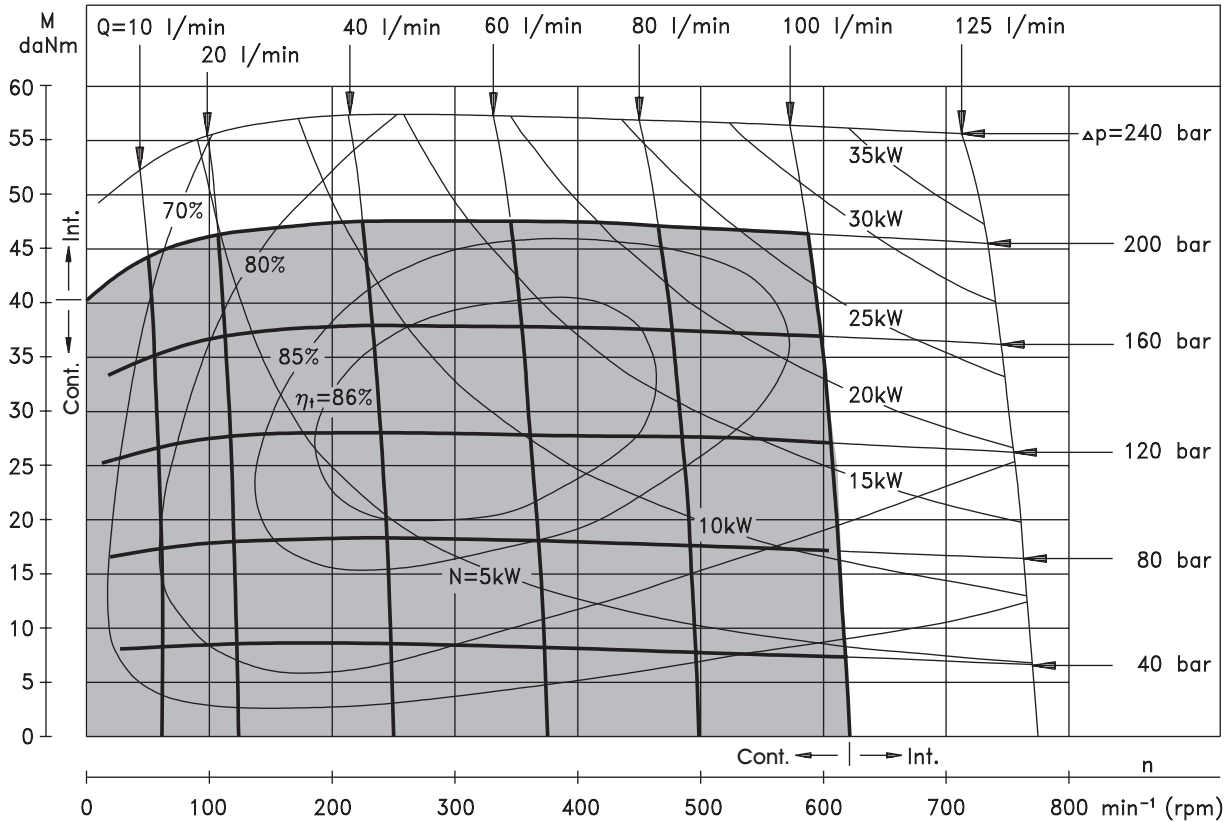

EPMT 200

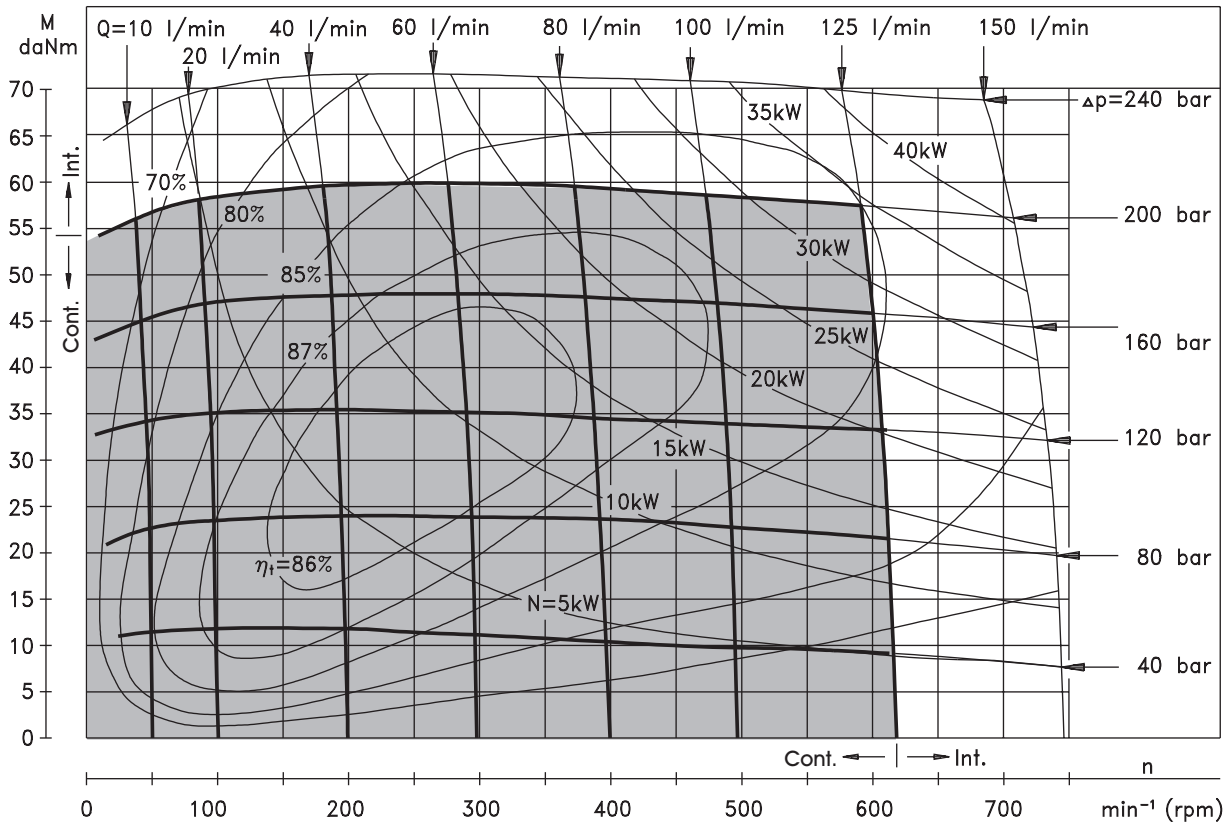

The function diagrams data was collected at back pressure 5 ± 10 bar and oil with viscosity of $32 \text{ mm}^2/\text{s}$ at 50° C .

FUNCTION DIAGRAMS

EPMT 250

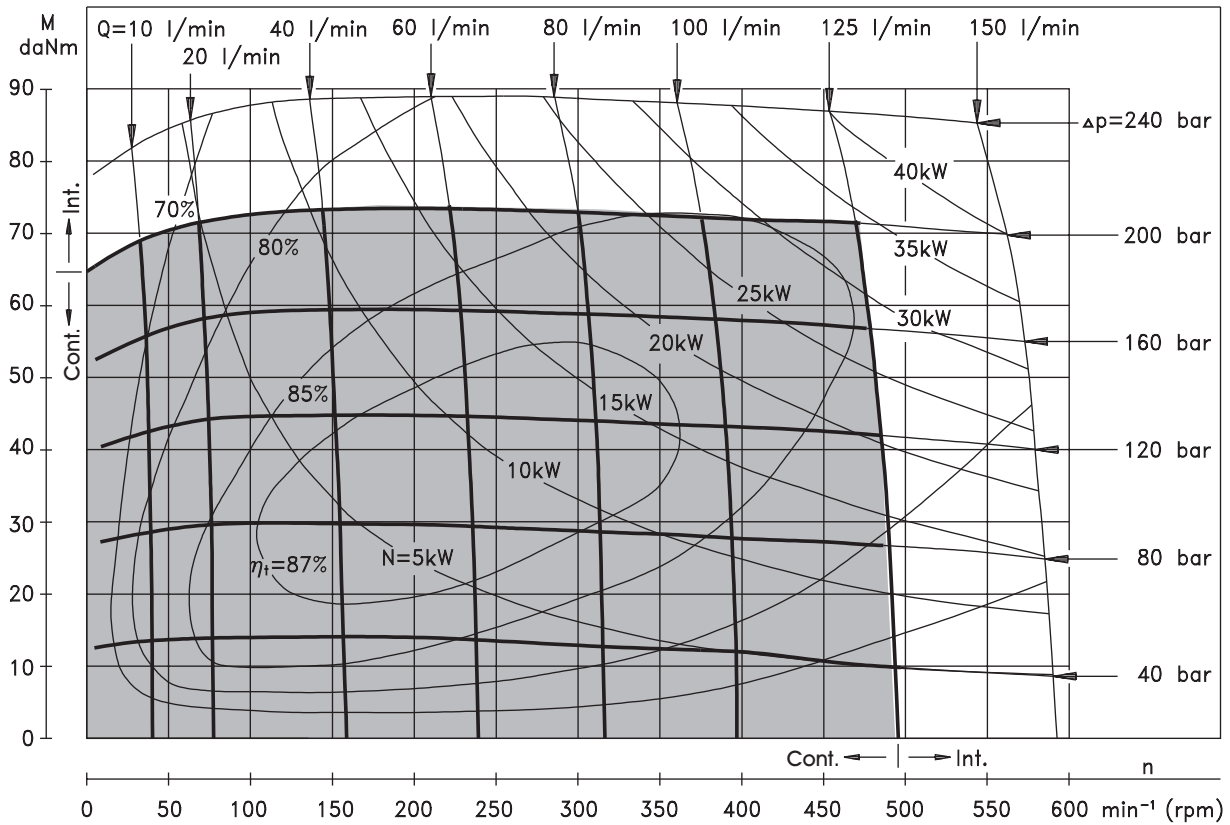

EPMT 315

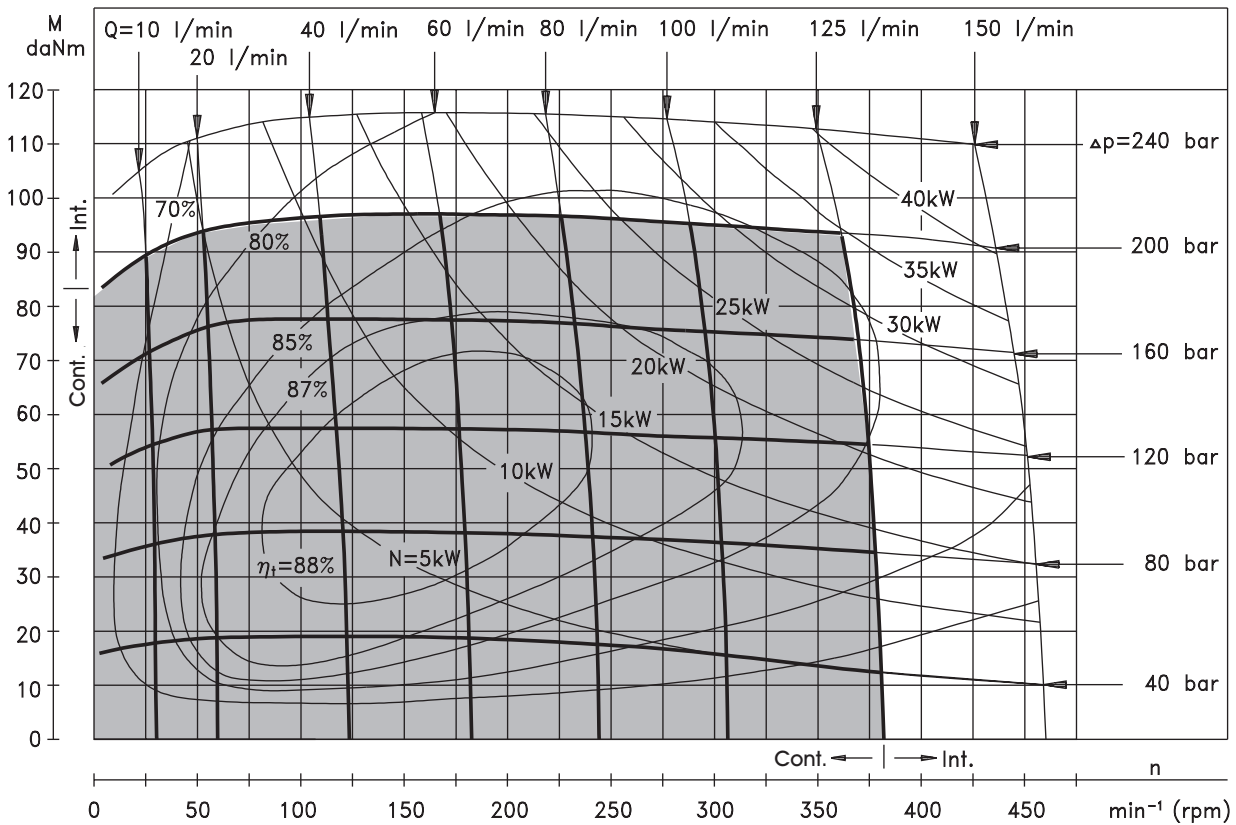

FUNCTION DIAGRAMS

EPMT 400

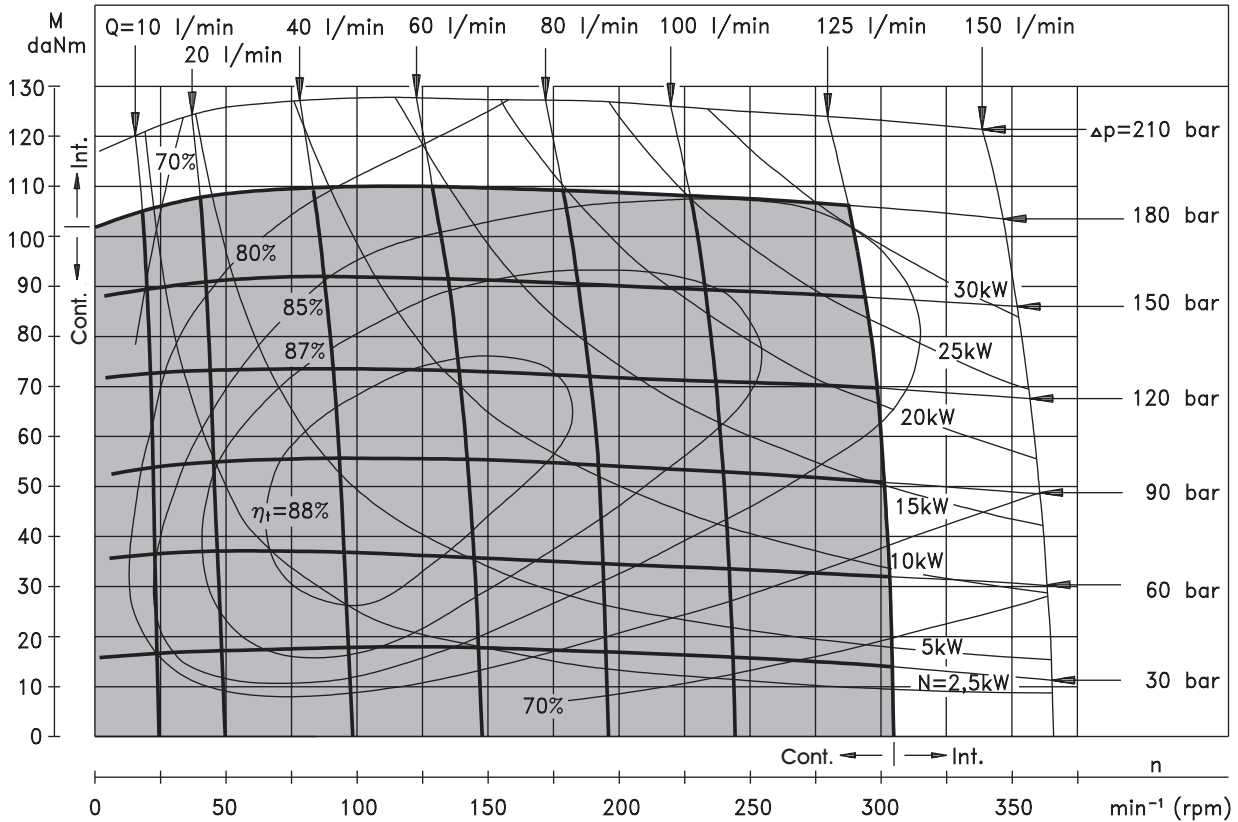

EPMT 500

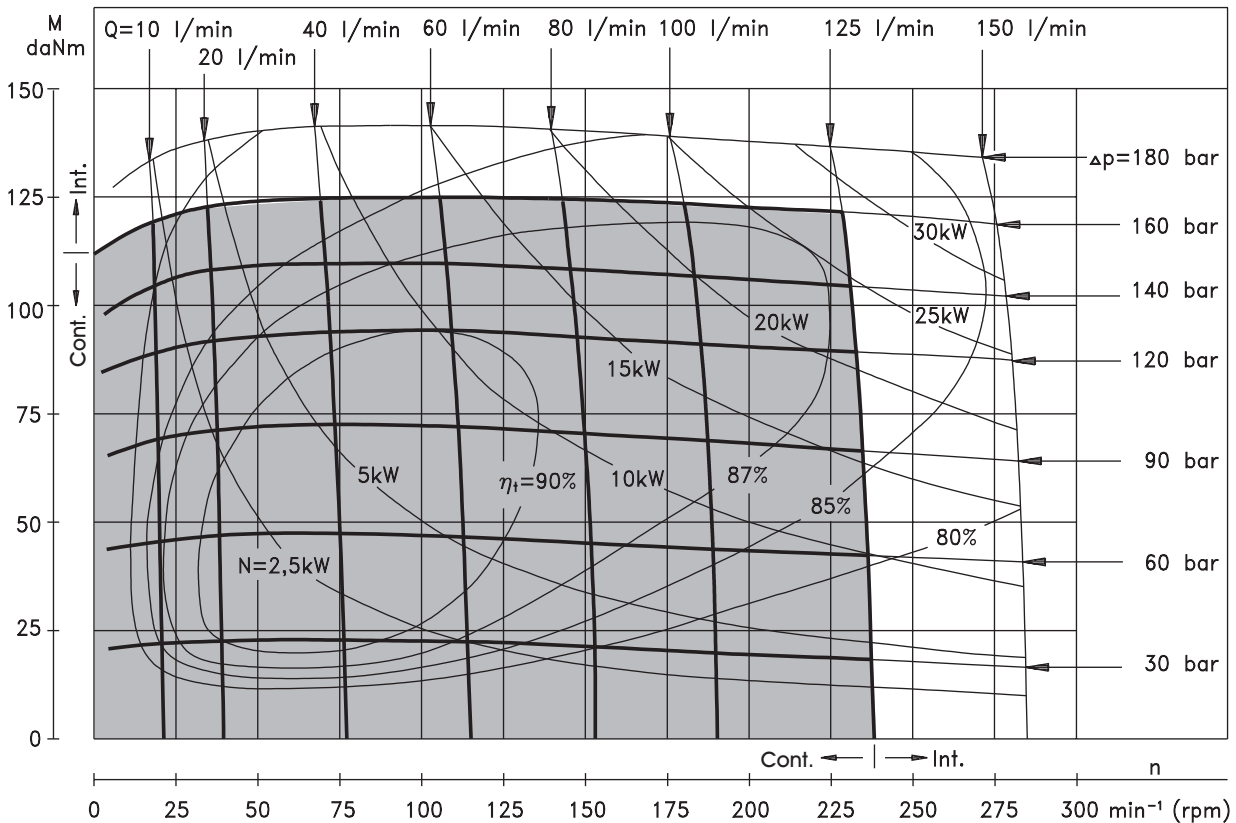

The function diagrams data was collected at back pressure 5÷10 bar and oil with viscosity of 32 mm²/s at 50° C.

DIMENSIONS AND MOUNTING DATA

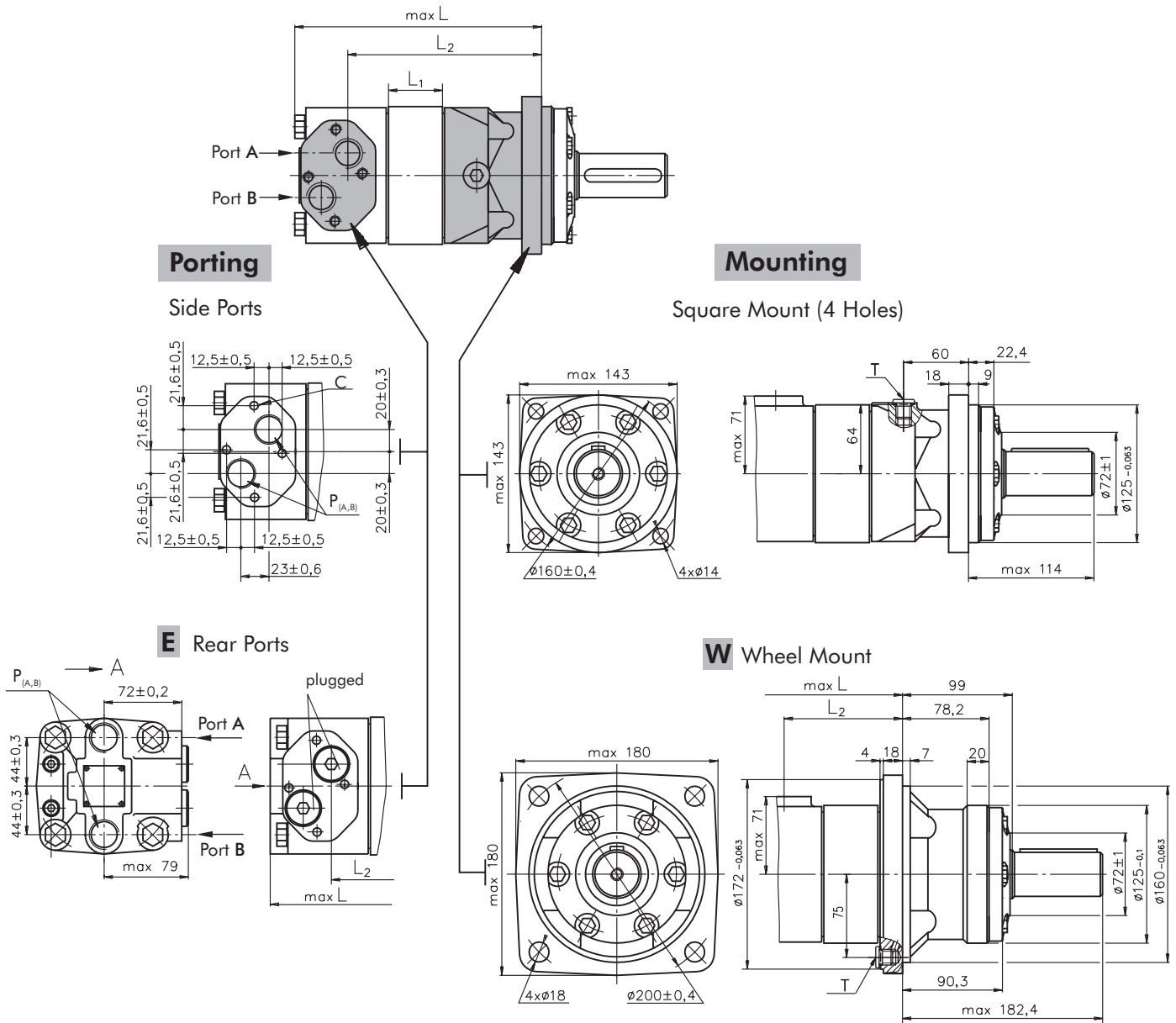

Standard Rotation
Viewed from Shaft End
Port A Pressurized - CW
Port B Pressurized - CCW

Reverse Rotation
Viewed from Shaft End
Port A Pressurized - CCW
Port B Pressurized - CW

C: 4xM10-10 mm depth
P_(A,B): 2xG3/4 or 2xM27x2-17 mm depth
T: G 1/4 or M14x1,5 - 12 mm depth (plugged)

Type	L, mm	Type	L, mm	L ₂ , mm	Type	L, mm	Type	L, mm	L ₂ , mm	*L ₁ , mm
EPMT 160	190	EPMTE 160	200	140	EPMTW 160	123	EPMTWE 160	133	73	16,5
EPMT 200	195	EPMTE 200	205	145	EPMTW 200	128	EPMTWE 200	138	78	21,5
EPMT 250	201	EPMTE 250	211	151	EPMTW 250	134	EPMTWE 250	144	84	27,8
EPMT 315	211	EPMTE 315	221	161	EPMTW 315	144	EPMTWE 315	154	94	37,0
EPMT 400	221	EPMTE 400	231	171	EPMTW 400	154	EPMTWE 400	164	104	47,5
EPMT 500	235	EPMTE 500	245	185	EPMTW 500	168	EPMTWE 500	178	118	61,5
EPMT 630	242,5	EPMTE 630	252,5	192,5	EPMTW 630	175,5	EPMTWE 630	185,5	125,5	72,5
EPMT 725	260	EPMTE 725	270	210	EPMTW 725	193	EPMTWE 725	193	143	86,5

* The width of the gerolor is 3,5 mm greater than L₁.

SHAFT EXTENSIONS

C - $\phi 40$ straight, Parallel key A12x8x70 DIN 6885
Max. Torque 132,8 daNm

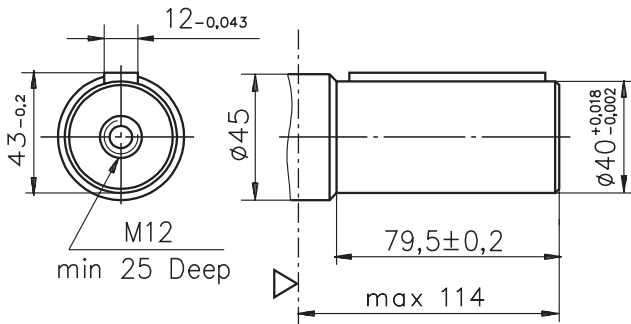

K -tapered 1:10, Parallel key B12x8x28 DIN 6885
Max. Torque 210,7 daNm

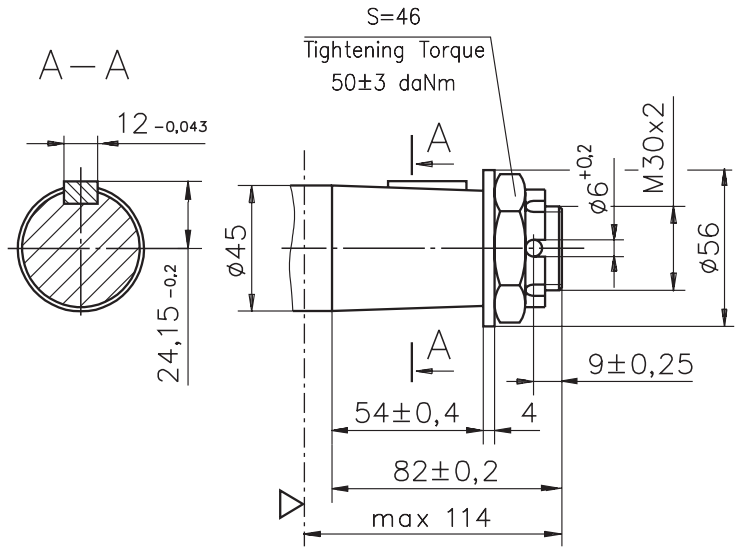

CO - $\phi 1\frac{1}{2}$ " straight, Parallel key $\frac{3}{8}$ "x $\frac{3}{8}$ "x $2\frac{1}{4}$ " BS46
Max. Torque 132,8 daNm

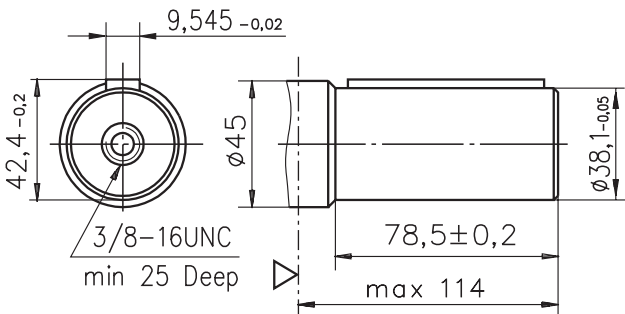

SH - $\phi 1\frac{1}{2}$ " splined 17T, DP 12/24 ANSI B92.1-1976
Max. Torque 132,8 daNm

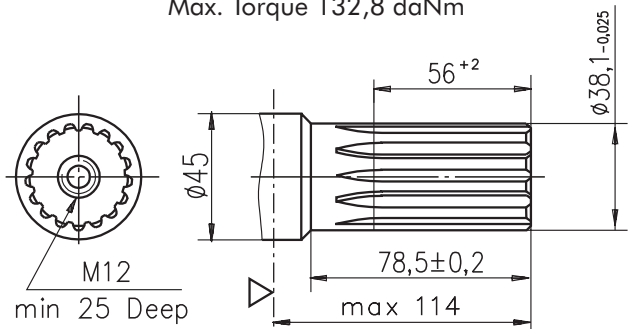

SL - $\phi 34,85$ p.t.o. DIN 9611 Form 1
Max. Torque 77 daNm

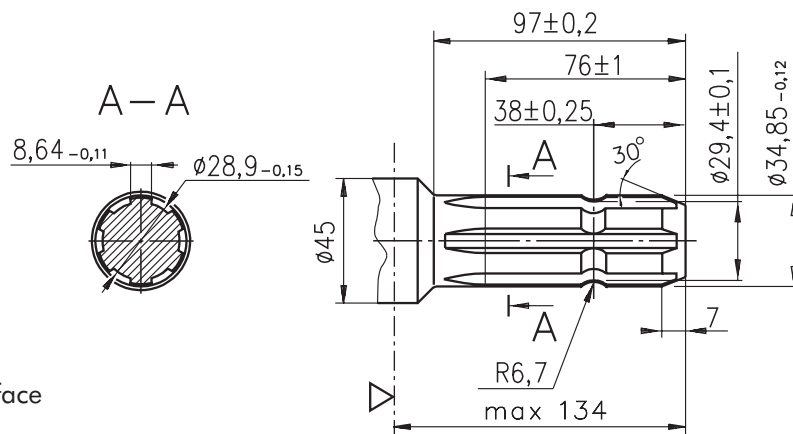

▽ - Motor Mounting Surface

DIMENSIONS AND MOUNTING DATA - EPMTs and EPMTV

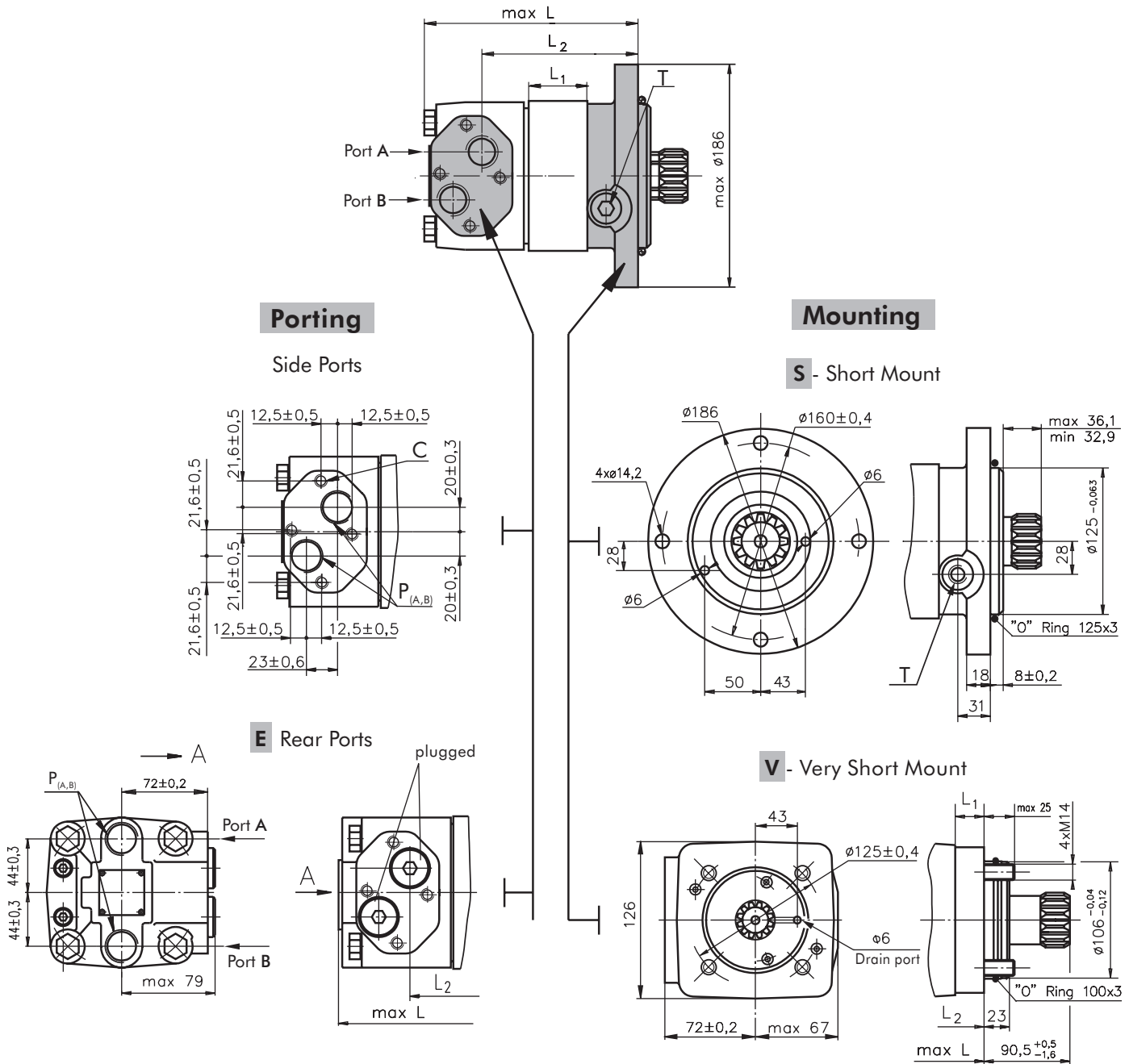

Standard Rotation
Viewed from Shaft End
Port A Pressurized - CW
Port B Pressurized - CCW

Reverse Rotation
Viewed from Shaft End
Port A Pressurized - CCW
Port B Pressurized - CW

C: 4xM10-10 mm depth
P_(A,B): 2xG3/4 or 2xM27x2-17 mm depth
T: G 1/4 or M14x1,5 - 12 mm depth (plugged)

Type	L, mm	Type	L, mm	L ₂ , mm	Type	L, mm	Type	L, mm	L ₂ , mm	*L ₁ , mm
EPMTS 160	146	EPMTSE 160	156	96	EPMTV 160	101	EPMTVE 160	111	51,5	16,5
EPMTS 200	151	EPMTSE 200	161	101	EPMTV 200	106	EPMTVE 200	116	56,5	21,5
EPMTS 250	157	EPMTSE 250	167	107	EPMTV 250	112	EPMTVE 250	122	62,8	27,8
EPMTS 315	166	EPMTSE 315	176	116	EPMTV 315	121	EPMTVE 315	131	72	37,0
EPMTS 400	177	EPMTSE 400	187	127	EPMTV 400	132	EPMTVE 400	142	82,5	47,5
EPMTS 500	191	EPMTSE 500	201	142	EPMTV 500	146	EPMTVE 500	156	96,5	61,5
EPMTS 630	198,5	EPMTSE 630	208,5	146,5	EPMTV 630	153,5	EPMTVE 630	163,5	104	72,5
EPMTS 725	216	EPMTSE 725	226	167	EPMTV 725	171	EPMTVE 725	181	121,5	86,5

* The width of the gerolor is 3,5 mm greater than L₁.

DIMENSIONS OF THE ATTACHED COMPONENT

EPMTS

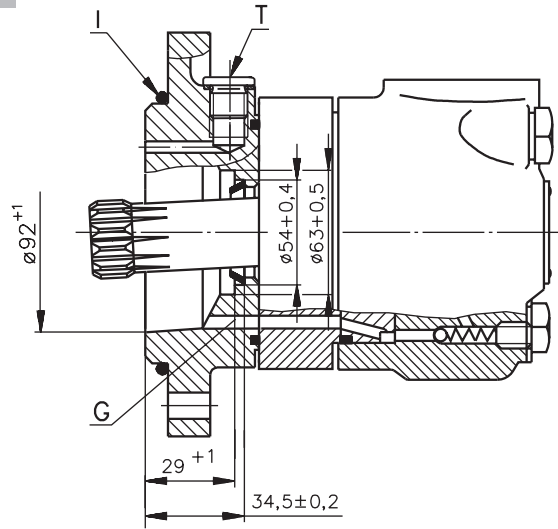
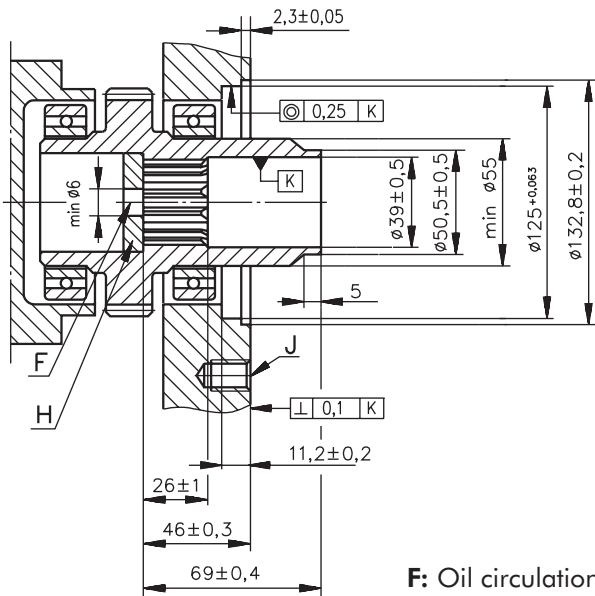

- F:** Oil circulation hole
- G:** Internal drain channel
- H:** Hardened stop plate

- I:** O- Ring 125x3mm
- J:** 4xM12-18 mm depth, 90°
- T:** Drain connection G1/4 or M14x1,5

EPMTV

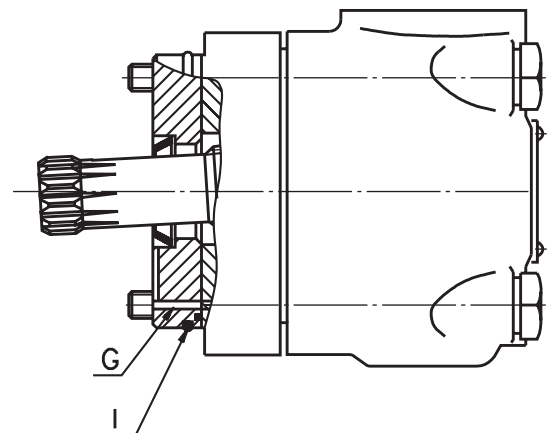
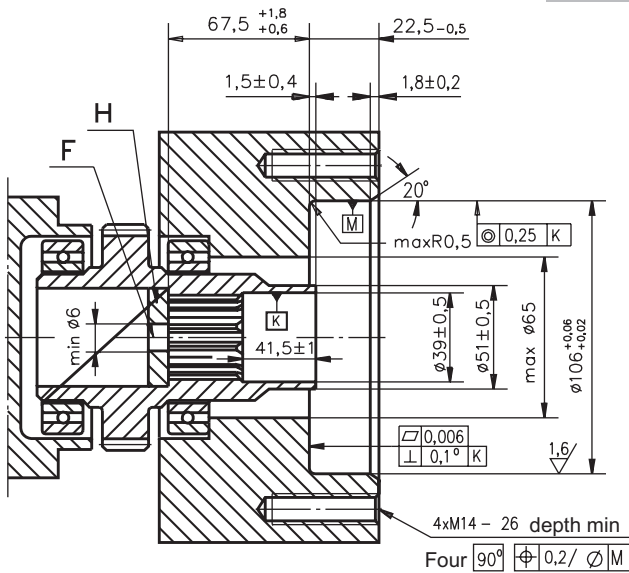

- F:** Oil circulation hole
- G:** Internal drain channel

- H:** Hardened stop plate
- I:** O- Ring 100x3mm

DRAIN CONNECTION

A drain line ought to be used when pressure in the return line can exceed the permissible pressure. It can be connected:

- For EPMTS at the drain port of the motor;
- For EPMTV at the drain connection of the attached component. The maximum pressure in the drain line is limited by the attached component and its shaft seal.

The drain line must be possible for oil to flow freely between motor and attached component and must be led to the tank. The maximum pressure in the drain line is limited by the attached component and its seal.

INTERNAL SPLINE DATA FOR THE ATTACHED COMPONENT

Standard ANSI B92.1-1976, class 5
 [m=2.1166; corrected x.m=+1,0]

Fillet Root Side Fit		mm
Number of Teeth	z	16
Diametral Pitch	DP	12/24
Pressure Angle		30°
Pitch Dia.	D	33,8656
Major Dia.	D _{ri}	38,4 ^{+0,4}
Minor Dia.	D _i	32,15 ^{+0,04}
Space Width [Circular]	Lo	4,516±0,037
Fillet Radius	R _{min}	0,5
Max. Measurement between Pin	L	26,9 ^{+0,10}
Pin Dia.	d	4,835±0,001

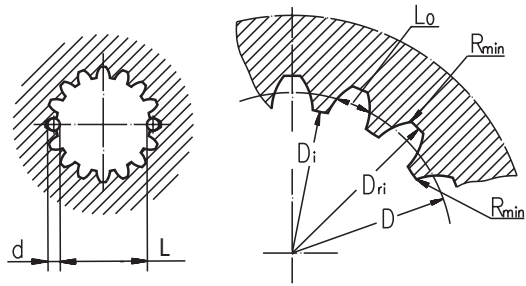

Hardening Specification:
 HRC 60±2
 HRC 52
 0,7±0,2 mm effective case depth
 Material 20 MoCr4 DIN 17210 or better

PERMISSIBLE SHAFT LOADS

The output shaft runs in tapered bearings that permit high axial and radial forces. Curve "1" shows max. radial shaft load. Any shaft load exceeding the values quoted in the curve will seriously reduce motor life. The two other curves apply to a B10 bearing life of 3000 hours at 200 RPM.

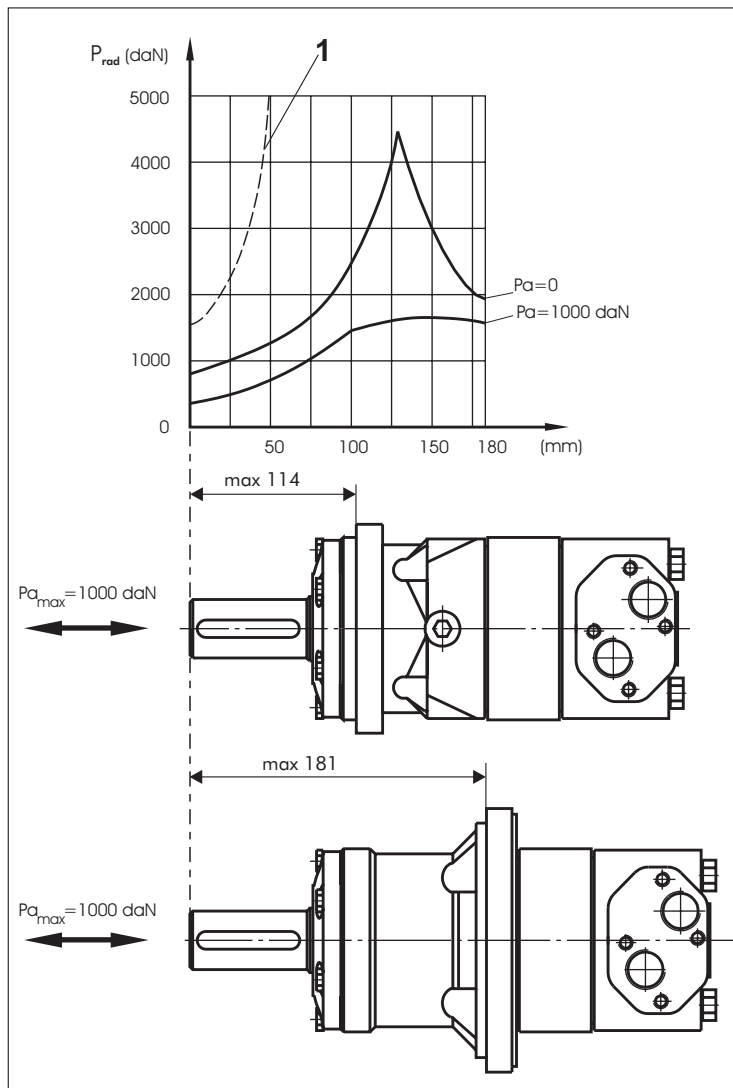

MOTORS WITH TACHO CONNECTION

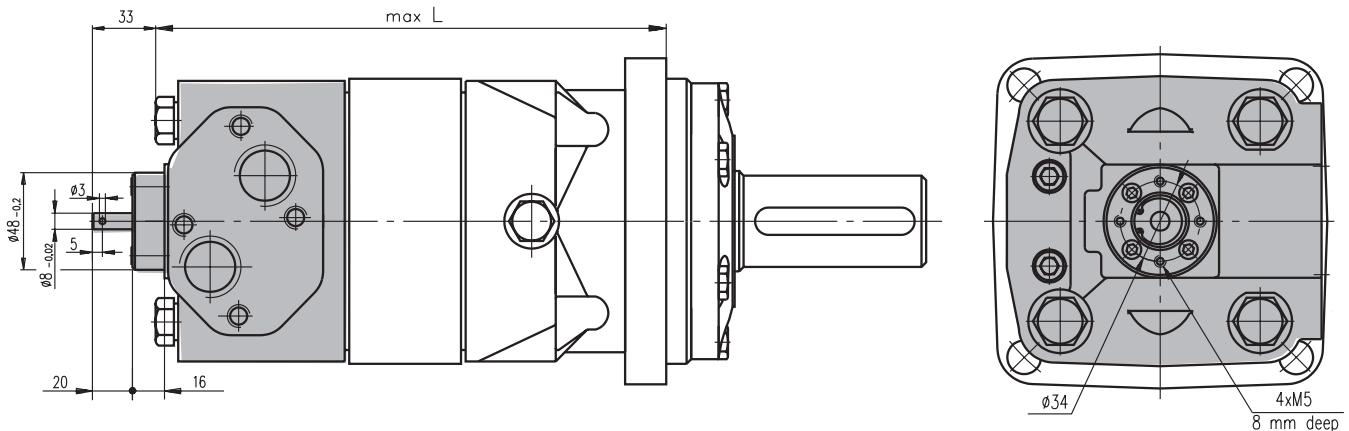

ORDER CODE

	1	2	3	4	5	6	7	8	9	10
E P M T										

Pos. 1 - Mounting Flange

omit - Square mount, four holes

S - Short mount

V - Very short mount

W - Wheel mount

Pos. 2 - Port type

omit - Side ports

E - Rear ports

Pos. 3 - Displacement code

160 - 161,1[cm³/rev]

200 - 201,4[cm³/rev]

250 - 251,8[cm³/rev]

315 - 326,3[cm³/rev]

400 - 410,9[cm³/rev]

500 - 523,6[cm³/rev]

630 - 612,3[cm³/rev] (without Function diagram)

725 - 725,0[cm³/rev] (without Function diagram)

Pos. 4 - Shaft Extensions*

C - ø40 straight, Parallel key A12x8x70 DIN6885

CO - ø1 1/2" straight, Parallel key 3/8"x3/8"x2 1/4" BS46

K - ø45 tapered 1:10, Parallel key B12x8x28 DIN6885

SL - ø34,85 p.t.o. DIN 9611 Form 1

SH - ø1 1/2" splined 17T ANSI B92.1-1976

Pos. 5 - Ports

omit - BSPP (ISO 228)

M - Metric (ISO 262)

Pos. 6 - Speed Monitoring

omit - none

T - with tachometer connection (only for side ports)

Pos. 7 - Special Features

omit - none

LL - Low Leakage

LSV - Low Speed Valve

Pos. 8 - Rotation

omit - Standard Rotation

R - Reverse Rotation

Pos. 9 - Option (Paint)**

omit - no Paint

P - Painted

PC - Corrosion Protected Paint

Pos. 10 - Design Series

omit - Factory specified

NOTES:

* The permissible output torque for shafts must be not exceeded!

** Color at customer's request.

The hydraulic motors are mangano-phosphatized as standard.