

Monobloc and Sectional Directional Control Valves

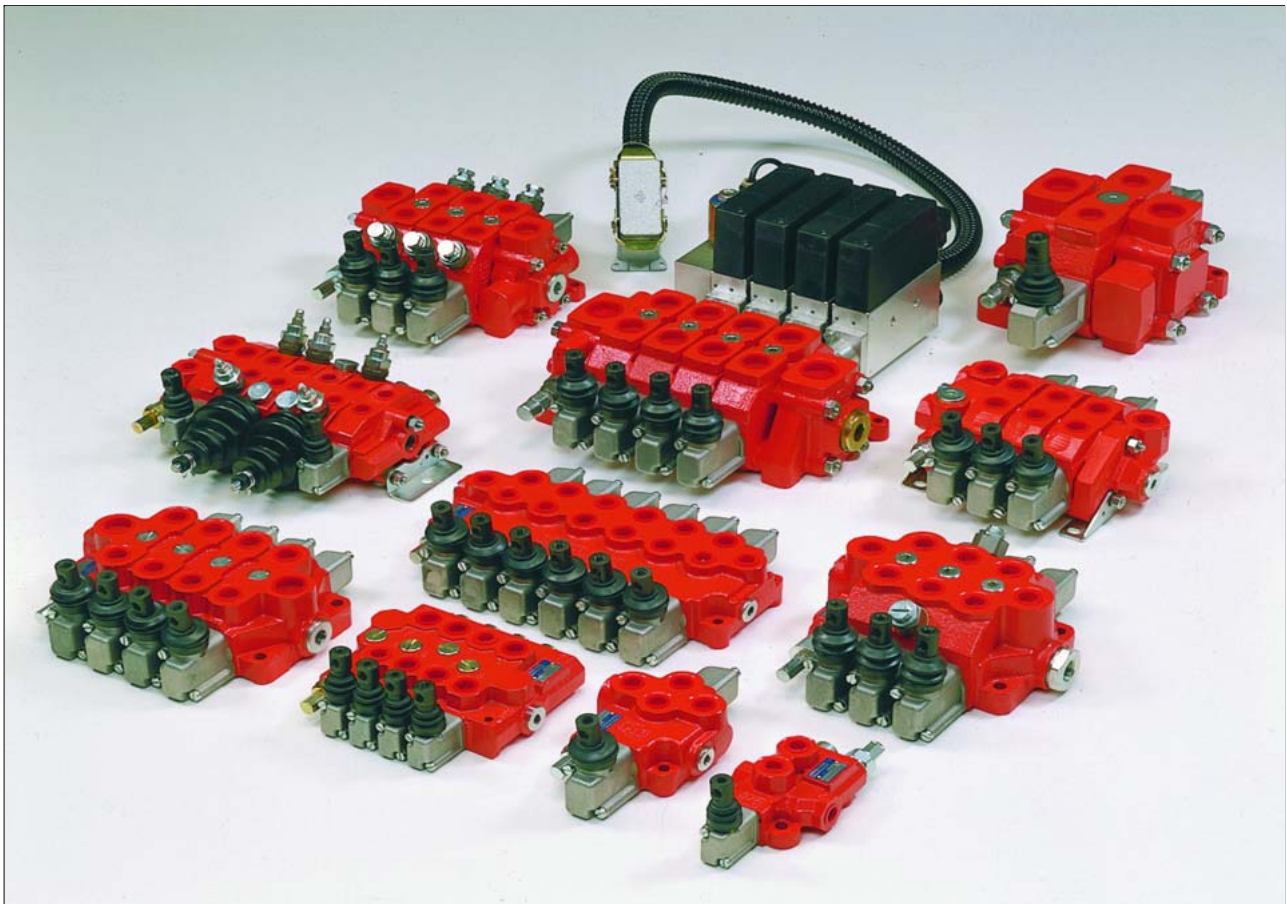

motion and progress

6 Monobloc directional control valves HDM25



Contents

6.1	General specifications	66
6.2	Dimensional data	67
6.3	Performances curves	68
6.4	Monobloc bodies	69
6.5	Adjustable direct acting Relief Valve RV	71
6.6	Spool charts	71
6.7	Spool actions	72
6.8	Spool positioners dimensions	72
6.9	Lever styles	73
6.10	Hydraulic-Pneumatic controls	75
6.11	Pneumatic controls	75
6.12	Hydraulic proportional control	76
6.13	Electro-hydraulic controls	77
6.14	Solenoids for pilot electrovalves EHI-EHE	78

6.1 General Specifications

Technical specification		
Max flow rate	l/min U.S.G.P.M.	100 25
Max continuous operating pressure supply port P	bar PSI	250 3600
Max intermittent peak pressure Work port A/B	bar PSI	320 4600
Max back pressure tank port T	bar PSI	30 430
Oil temperature	° C ° F	-10 to 80 14 to 180
Oil viscosity	mm ² /s	16 to 75
Oil filtration	μ	≤ 30

Spool leakage at 100 bar (1450 PSI), Temp. 50° C (120° F), viscosity 27 mm ² /s		
Maximum	cm ³ /min Cu. In./min	16 0.854
Average	cm ³ /min Cu. In./min	8 0.427
Lower values on demand (to be agreed with our Sales Dpt.)		

Number of spools	1 to 2
Adjustable direct operated relief valve (tamper-proof seal available on request)	RV
Load hold check valve in each section	LC

6.1.1 Weight

Version	kg	lb
HDM25/1	5.9	13
HDM25/2	9	19.8

6.1.2 Material specification:

Body: High strength cast-iron.
Spool: Hardened steel and chrome plated
Seals: Buna "N".

6.1.3 Standard features:

- 1) Internal load holding check valves (prevent reverse flow through valve when two spools are operated)
- 2) Parallel circuit
- 3) Balanced interchangeable spools (provides minimum leakage, smooth operation)
- 4) Wide selection inlets, work ports, and outlets threaded ports.
- 5) Negative overlapping of the spool.

6.1.4 Optional features available:

- 1) Open or closed centre positions, 3 or 4 way operations, 3 or 4 position (float position), full open centre (motor spool) and other spool options.
- 2) Carry over.
- 3) Series connection and tandem
- 4) Complete lever assembly

6.1.5 Symbols:

P: inlet port
T: outlet port
A/B: work ports
H.P.C.O.: carry-over
RV: relief valve
P₁T₁: side inlet and outlet ports
 3.1.0.2: spool position
P: pressure line
T: exhaust line
E: centre line (by pass).

6.2 Dimensional Data

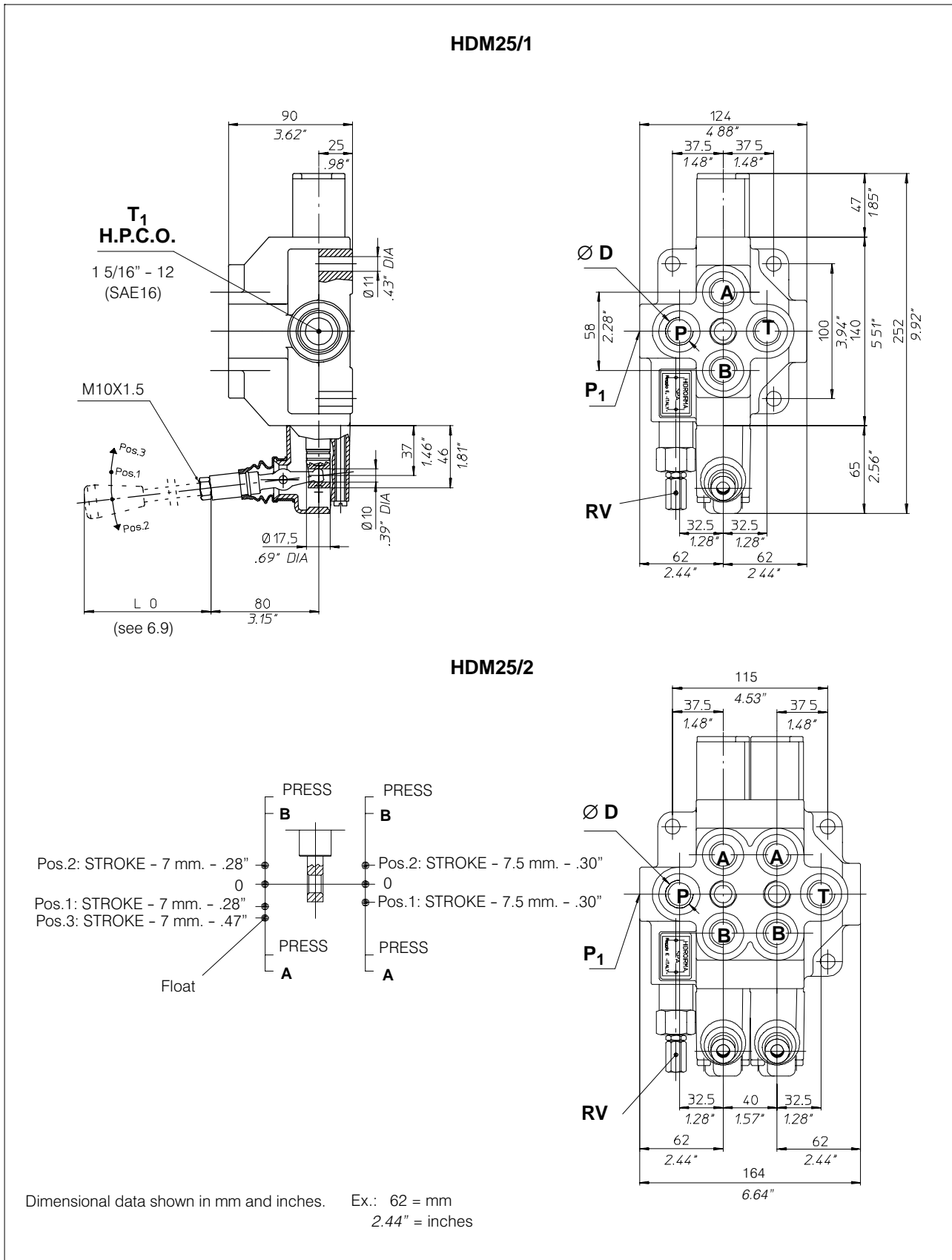

6.3 Performance curves

Oil: Shell Tellus T37
 Temperature: 50° C (120° F)
 Viscosity: 27 mm²/s

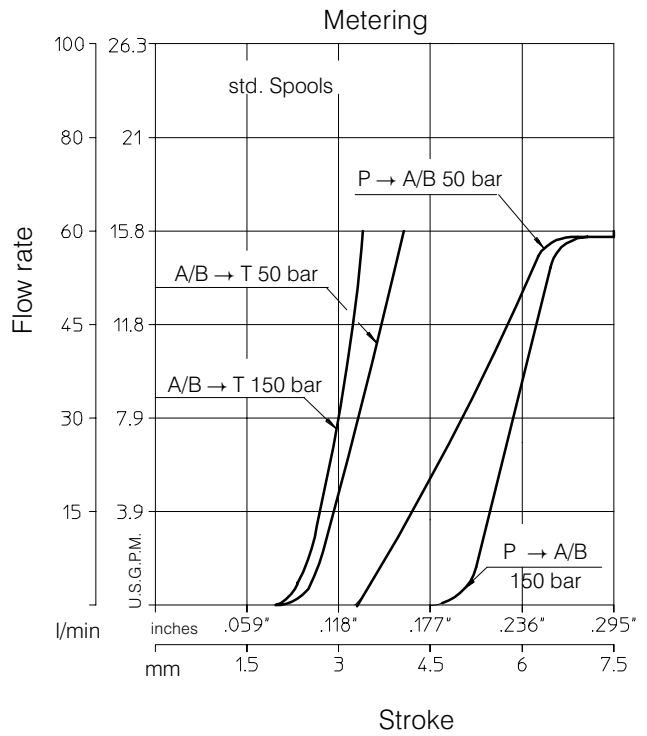
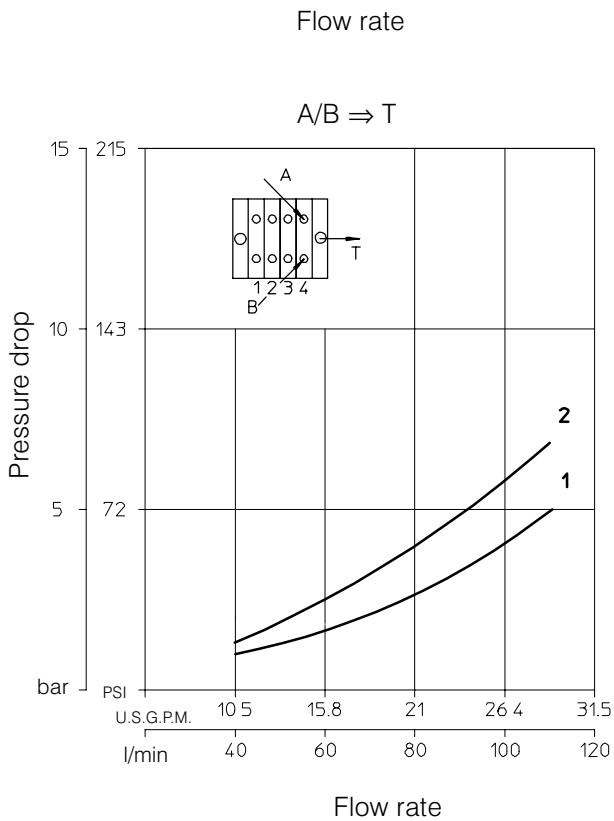
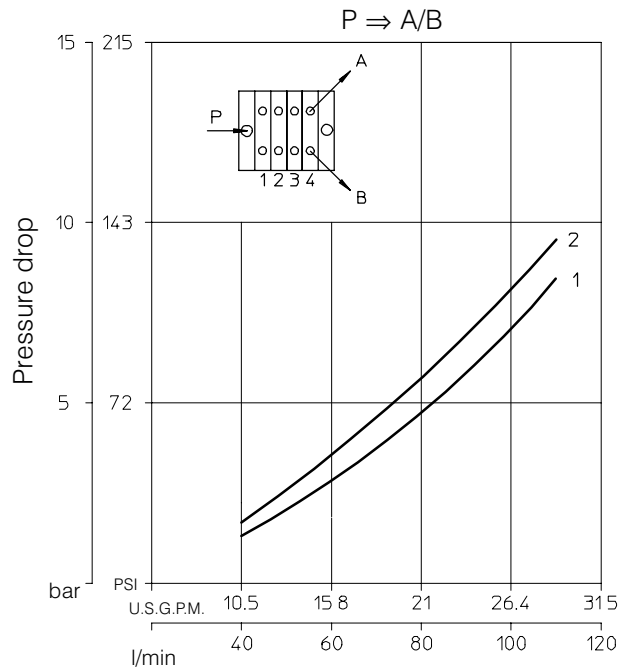
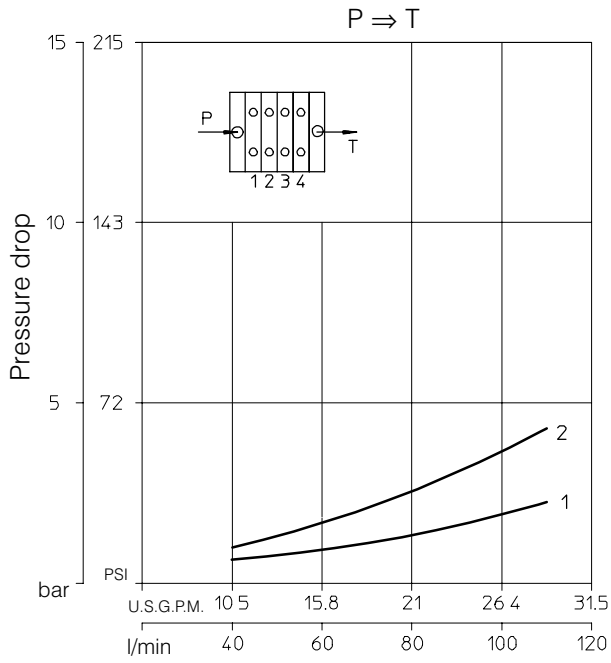

6.4 Monobloc bodies

6.4.1 Open centre with P – T – RV
(Standard circuits: parallel)

Ø D	Code	
	HDM25/1	HDM25/2
M18X1.5	K01	K01
1/2" BSP Std.	K02 200.9441.3001.0	K02 200.9442.3001.0
3/4" BSP	K03 200.9441.4001.0	K03 200.9442.4001.0
SAE10	K04	K04
SAE12	K05	K05

6.4.2 Power beyond with P – T – RV – H.P.C.O.
(Standard circuits: parallel)

Ø D	Type/Code	
	HDM25/1	HDM25/2
M18X1.5	K21	K21
1/2" BSP Std.	K22 200.9441.3002.0	K22 200.9442.3003.0
3/4" BSP	K23 200.9441.4003.0	K23 200.9442.4002.0
SAE10	K24	K24
SAE12	K25	K25

Note: Body codes consist of: machined casting, seals, plugs and check valve only. Not to be used for complete valve order.
For availability of -K- bodies without code please contact our Sales Department.

6.4.3 Open centre with P – T – RV
(Optional circuits: series and tandem)

Ø D	Type/Code
	Standard
M18X1.5	K31
1/2" BSP std.	K32
3/4" BSP	K33
SAE10	K34
SAE12	K35

6.4.4 Power beyond with P – T – RV – H.P.C.O.
(Optional circuits: series and tandem)

Ø D	Type/Code
	Standard
M18X1.5	K51
1/2" BSP std.	K52
3/4" BSP	K53
SAE10	K54
SAE12	K55

Note: Body codes consist of: machined casting, seals, plugs and check valve only. Not to be used for complete valve order.
For availability of -K- bodies without code please contact our Sales Department.

6.5 Adjustable direct acting Relief Valve RV

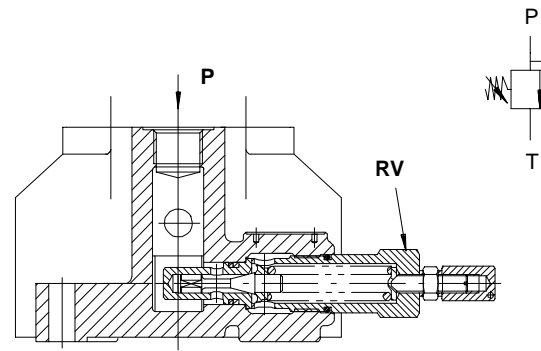
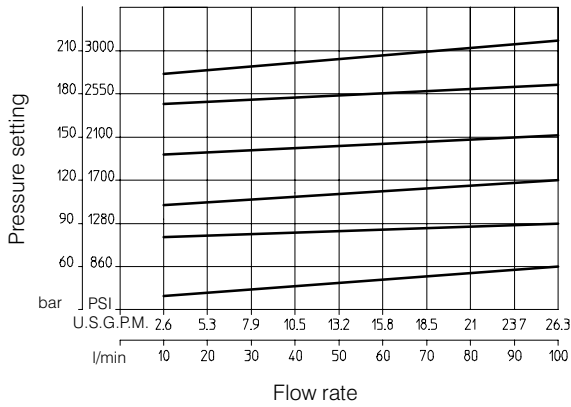

Relief valve set at 30 l/min (8 U.S.G.P.M.)

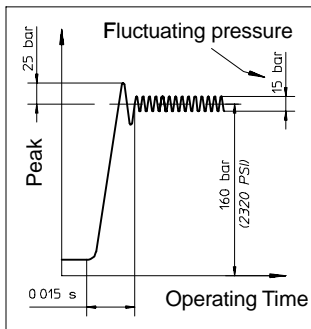

Pressure set range bar (PSI)	Std. setting bar (PSI)	Setting Code	Spring colour
30 - 95 (400 - 1300)	60 (860)	06	Yellow (YE)
96 - 210 (1300 - 3000)	150 (2100)	15	Green (GR)
211 - 300 (3000 - 4200)	260 (3700)	26	Blue (BL)
301 - 400 (4200 - 5700)	320 (4600)	32	Red (RD)

6.6 Spool charts

Spool scheme	Spool features	Type
	4 way - 3 position A/B: blocked E: open by pass	A As*
	4 way - 3 position A/B: blocked E: closed	B
	4 way - 3 position A/B to tank in neutral E: open by pass	C *Cs
	3 way - 3 position B: blocked E: open by pass	G *Gs
	4 way - 3 position B: blocked A: to tank in neutral	L

	4 way - 3 position with differential spool in 2 nd position	**R
	3 way - 3 position A: blocked E: open by pass	S *Ss
	4 way - 3 position series connection	X
	4 way - 3 position A: to tank in neutral	Xc
	4 way - 4 position 4 th float position	Z

** : special body required
* : Hight metering spool (max. flow suggested 50 l/min)

6.7 Spool positioners

Spool position				Stroke	Type	Code
3	1	0	2	mm		
○	○	*	○	7.5	01	200.9686.1002.0
●	●	○	○	7.5	02	200.9686.3002.0
●	●	●	○	7.5	03	200.9686.2002.0
	●	●	○	7.5	05	200.9686.2004.0
*			○	15	06	200.9686.1004.0
●	●			7.5	07	200.9686.2007.0
○	*			7.5	09	200.9686.1011.0
●		●		15	11	200.9686.2009.0
○	●	●		7.5	19	200.9686.3008.0
○	*	○		7.5	24	200.9686.5013.0
○	*	○		7.5	31	200.9686.1054.0
○	*	○		7.5	46	200.9686.1076.0
○	*	○		7.5	47	200.9686.1078.0
○	*	○		7.5	50	200.9686.5020.0
○	*	○		7.5	56	200.9686.1086.0
○	*	○		7.5	83	200.9686.1096.0
●	○	*	○	5 - 7 - 7	128	200.9686.4009.0

- * Initial hand lever position
- Hand lever in detent position
- Spring return position of hand lever

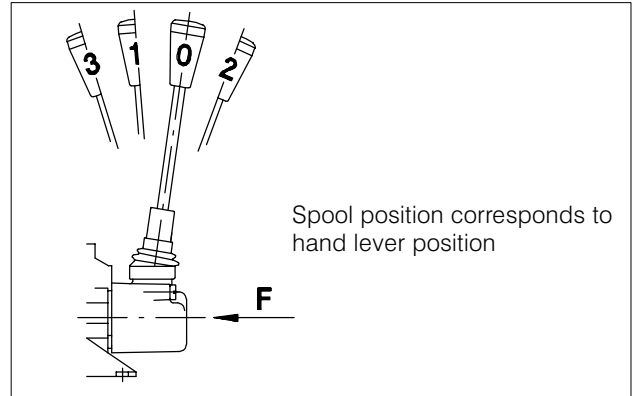

Force (F) for spool movement

F (N)	Spool position control
350	01 (standard)
280	56

Note: consult factory for different configurations.

6.8 Spool positioner dimensions

<p>Spool positioners 01 - 02 - 03 - 05 - 06 07 - 09 - 11 - 19 - 56</p>	<p>Spool positioner (Z spool type) 128</p>	<p>Spool positioner 83</p>

Microswitch control

31	Microswitch is operated when the spool is in pos. 1	
46	Microswitch is operated when the spool is in pos. 2	
47	Microswitch is operated when the spool is in pos. 1 and 2	

The microswitch is supplied only on customer's request.

6.9 Lever styles

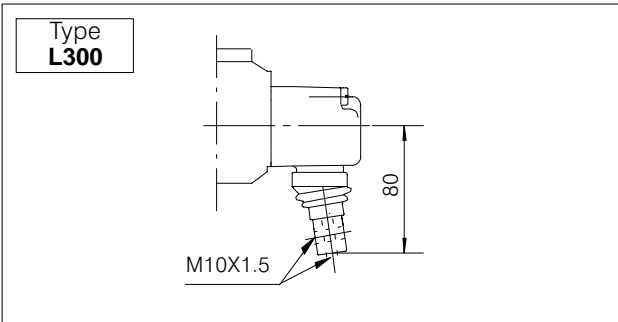
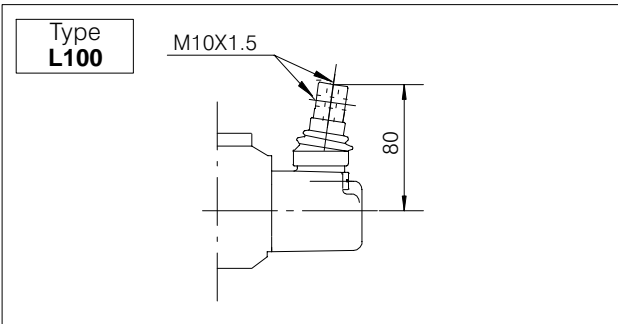
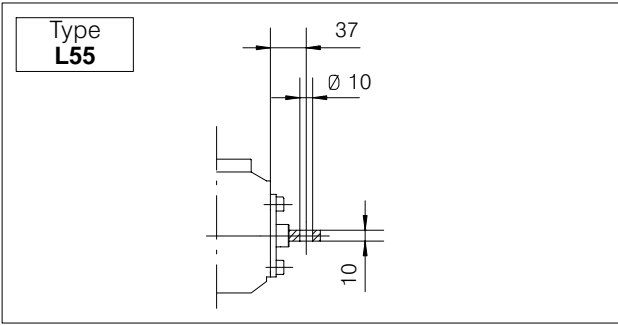

Lo		AL	Code
inches	mm		
7.28	185	001	200.7022.2001.0
9.84	250	002	200.7022.2003.0
11.81	300	003	200.7022.2004.0
13.78	350	004	200.7022.2005.0

6.9.1 Safety levers

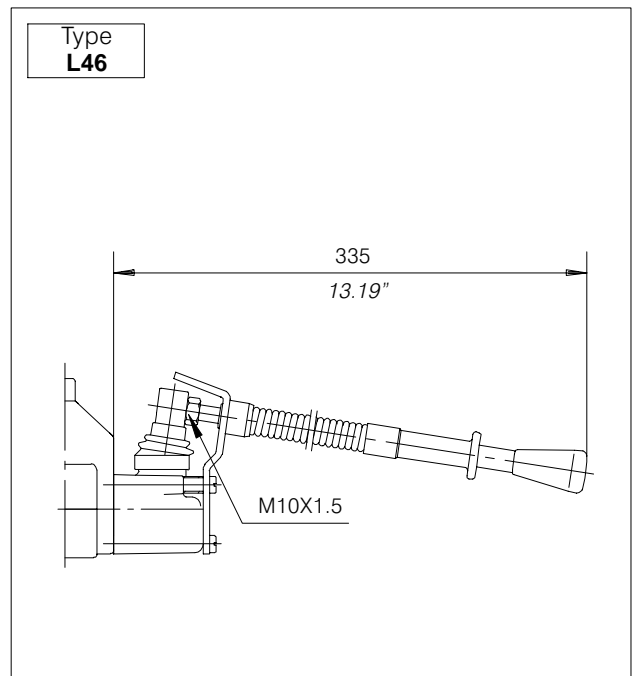
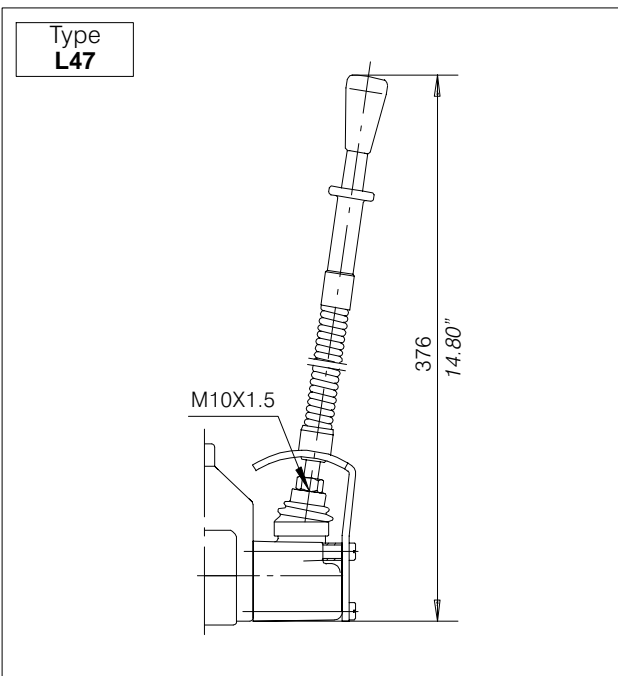

6.9.2 Remote cable control

Lever Support	Code 200.7609.0013.0
----------------------	-------------------------

M10X1.5

Optional
200.6772.0048.0

Lo		Type	Code
mm	inches		
185	7.28	AL001	200.7022.2001.0
250	9.84	AL002	200.7022.2003.0
300	11.81	AL003	200.7022.2004.0
350	13.78	AL004	200.7022.2005.0

M10X1.5

Cable	
--------------	--

Cable length	Code
1000 mm	200.5441.04002
1500 mm	200.5441.04005
2000 mm	200.5441.04006
2500 mm	200.5441.04007
3000 mm	200.5441.04008
4000 mm	200.5441.04009

Cables are assembled on the valve only on request and with an extra charge.

Spool Kit	
------------------	--

Code 200.9609.0002.0

Type L142	Code 200.7071.2012.0
------------------	-------------------------

M10X1.5

122 4.8"

42 1.65"

M8x1.25

150 5.9"

35 1.38"

40 1.57"

68 2.68"

40 1.57"

9 .35"

Optional
6772.0048.0

Only for rod remote control

Type L133	Code 200.9759.3007.0
------------------	-------------------------

Fulcrum

A₁ A₂ B₁ B₂

(AL010)

Stick Lever
M12X1.75

Fulcrum

6.9.3 Cross joystick for dual axis control

Type AL010	Code 200.7022.3004.0
-------------------	-------------------------

Lo=250

M12X1.75

Type L134	Code 200.9759.3007.0
------------------	-------------------------

1 2

A A

B B

P T

L133-134 is supplied complete with rubber boot protection

6.10 Hydraulic-Pneumatic controls ON-OFF

Type	Code
HP 24	200.9686.5013.0

Operating conditions
 Hydraulic
 Pressure range (bar): Min. 6 - Max. 15
 (PSI): Min. 85 - Max. 215
 Pneumatic
 Pressure range (bar): Min. 6 - Max. 10
 (PSI): Min. 85 - Max. 145

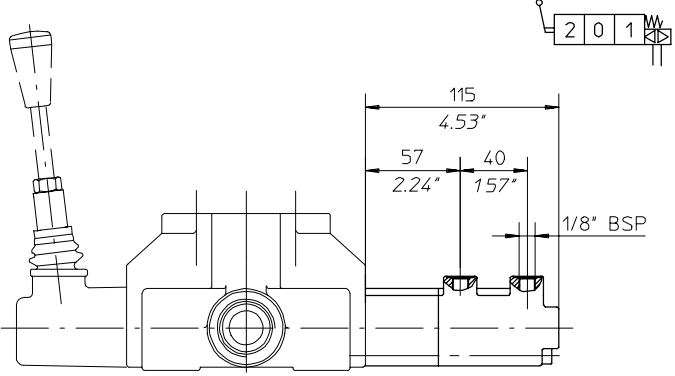

6.11 Pneumatic controls

6.11.1 Pneumatic proportional control

Type	Code
PP 151	200.9686.5010.0

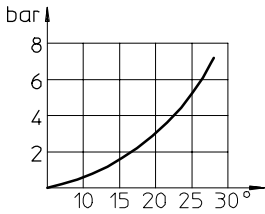
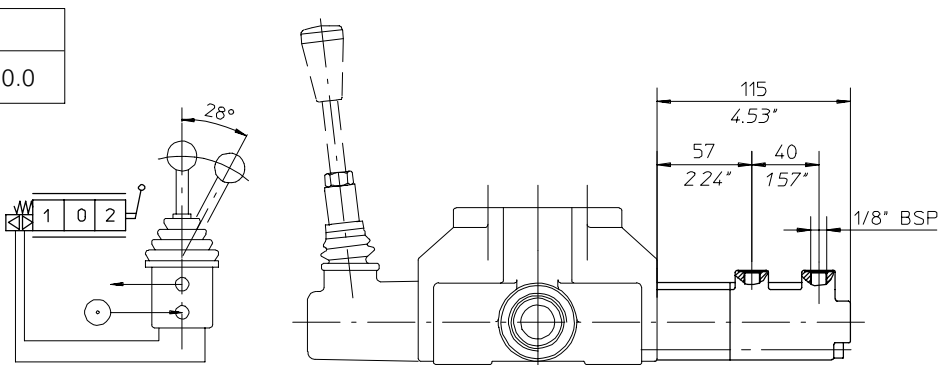
6.11.2 Electro-pneumatic control ON-OFF

Type	Voltage	Code
EP 77	12 VDC	200.9686.6024.0
EP 78	24 VDC	200.9686.6027.0

Electrical data
 Insulation class H - 180° C (356° F)
 Encapsulation material: nylon
 Temperature range:
 -10° C to 80° C (14° F to 170° F)
 Duty cycle: 100% at 68° F ambient
 Voltage variation: -10% to + 15% of nominal voltage
 Power consumption DC - 10 W
 Electrical connection: DIN43650/A (2P + E)
 Cable connection PG9
 Protection class: IP65 (with connector)

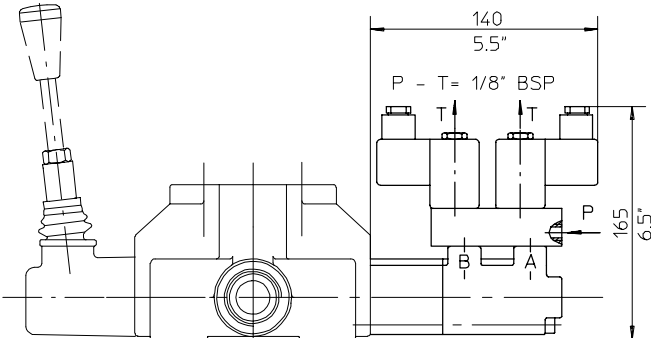

Operating conditions
 Pressure range (bar): Min. 6 - Max. 10
 (PSI): Min. 85 - Max. 145
 Ambient temperature: -10° C to 50° C (14° F to 122° F)
 Response time: 6 - 8 milliseconds
 Mounting in any position

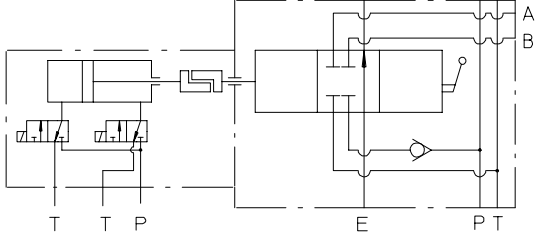

6.12 Hydraulic proportional control

Type	Code
HP 50	200.9686.5020.0

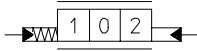

Joystick adjustment diagram

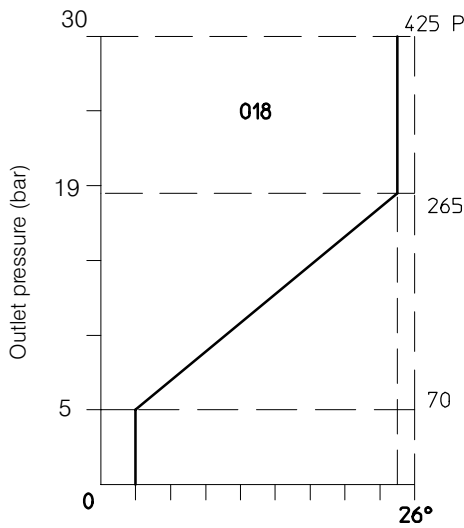

Adjustment range (bar): Min. 5 - Max. 30
 (PSI): Min. 70 - Max. 425

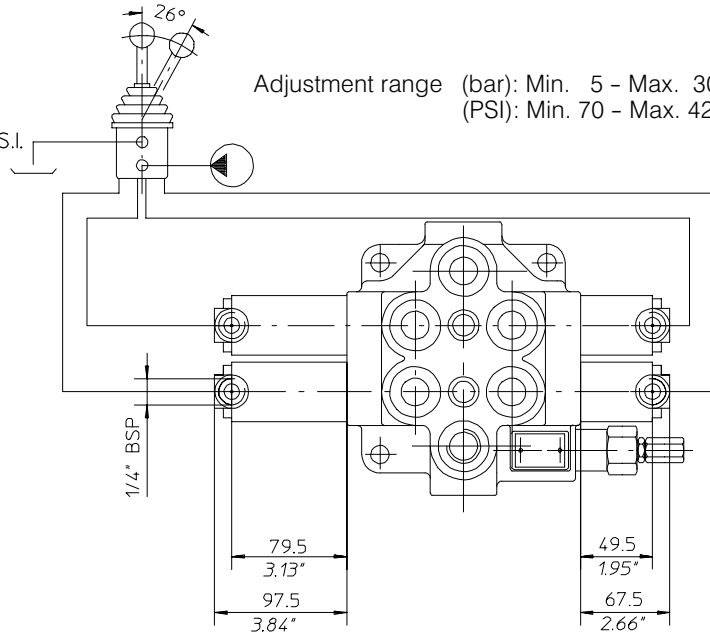

6.13 Electro-hydraulic controls

6.13.1 Electro-hydraulic control external pilot version ON-OFF

Type	Description	Code
EHE 301	Inlet section	200.9686.6051.0

Type	Description	Code
EHE 300	Inlet section	200.9686.6033.0
EHE 305	End section	200.9686.6037.0

6.13.2 Electro-hydraulic control external pilot version ON-OFF with pressure reducing valve on inlet manifold

Type	Description	Code
EHE 303	Inlet section	200.9686.6058.0

Type	Description	Code
EHE 302	Inlet section	200.9686.6032.0
EHE 305	End section	200.9686.6037.0

Mechanical and hydraulic features

Pilot pressure with pressure reducing valve 12 bar (175 PSI)
 Pilot flow to each working section: . . . 1 l/min (0.26 USGPM)
 Min. suggested filtration 25 micron

Operating oil temperature min.-30°C- max. 90°C
 min.-22°F - max 194°F
 Leakage of pressure reducing valve (in neutral pos.) 100 ml/min (6.1 in³/min)

6.14 Solenoids for pilot electrovalves EHE

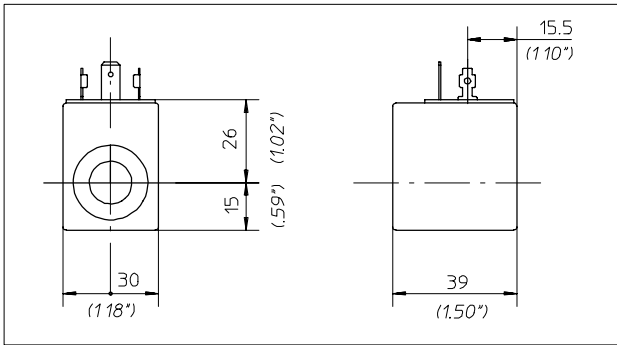

Wire class	F (VDE 0580)
Coil insulation	IP65 (DIN 40050)
Duty rating	ED 100%
Stabilized temperature	70 °C
Voltage tolerance	± 10%

Supply Voltage	Nominal coil voltage	Power (Watt)	Resistance (Ohm)		Current (Ampere)		Coil code
			Ambient temperature	Stabilized temperature	Ambient temperature	Stabilized temperature	
12 V. DC	12 V. DC	18.7	7.7	10.8	1.56	1.11	200.6749.1003.0
24 V. DC	24 V. DC	18.6	31	41.4	0.77	0.58	200.6749.2003.0
24 V. AC	21.6 V. DC	17.3	27	36	0.80	0.60	200.6748.2003.0
110 V. AC	98 V. DC	15.6	630	825	0.157	0.120	200.6748.4003.0
220 V. AC	198 V. DC	15.7	2500	3300	0.08	0.06	200.6748.6003.0

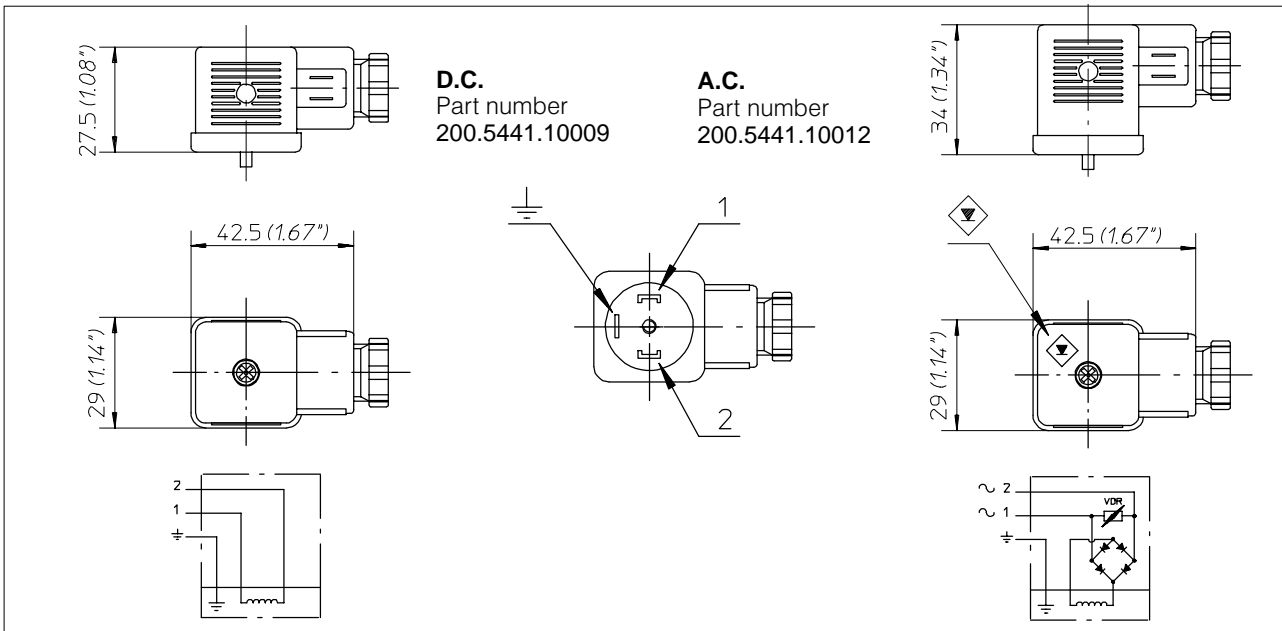

Armour clamp	Pg 9
Ø cable	6 - 8 mm
Diodes	1N 4007 GP
Overvoltage protection	VDR
Connector type	DIN 43650
Number of poles	2 + $\frac{1}{2}$
Supply voltage	max. 220 V
Nom. capacity at contacts	10 Ampere

Max capacity at contacts	16 Ampere
Resistance at contacts	≥ 4 mOhm
Max section of cable	1.5 mm ²
Outer material	Glass fibre reinforced nylon
Protection factor	IP65 (DIN 40050)
Insulation class	C (VDE 0110)
Temperature range	-40° +90°C

BUCHER HYDRAULICS

www.bucherhydraulics.com

Germany

Phone +49 7742 85 20
Fax +49 7742 71 16
info.de@bucherhydraulics.com

France

Phone +33 389 64 22 44
Fax +33 389 65 28 78
info.fr@bucherhydraulics.com

Netherlands

Phone +31 79 34 26 24 4
Fax +31 79 34 26 28 8
info.nl@bucherhydraulics.com

UK

Phone +44 24 76 35 35 61
Fax +44 24 76 35 35 72
info.uk@bucherhydraulics.com

USA

Phone +1 262 605 82 80
Fax +1 262 605 82 78
info.wi@bucherhydraulics.com

Switzerland

Phone +41 33 67 26 11 1
Fax +41 33 67 26 10 3
info.ch@bucherhydraulics.com

Italy

Phone +39 0522 92 84 11
Fax +39 0522 51 32 11
info.it@bucherhydraulics.com

Austria

Phone +43 6216 44 97
Fax +43 6216 44 97 4
info.at@bucherhydraulics.com

China

Phone +86 10 64 44 32 38
Fax +86 10 64 44 32 35
info.bj@bucherhydraulics.com

Product Center (Elevator)

Phone +41 41 757 03 33
Fax +41 41 755 16 49
info.nh@bucherhydraulics.com

We reserve the right of modification without prior notice.