

## Monobloc and Sectional Directional Control Valves

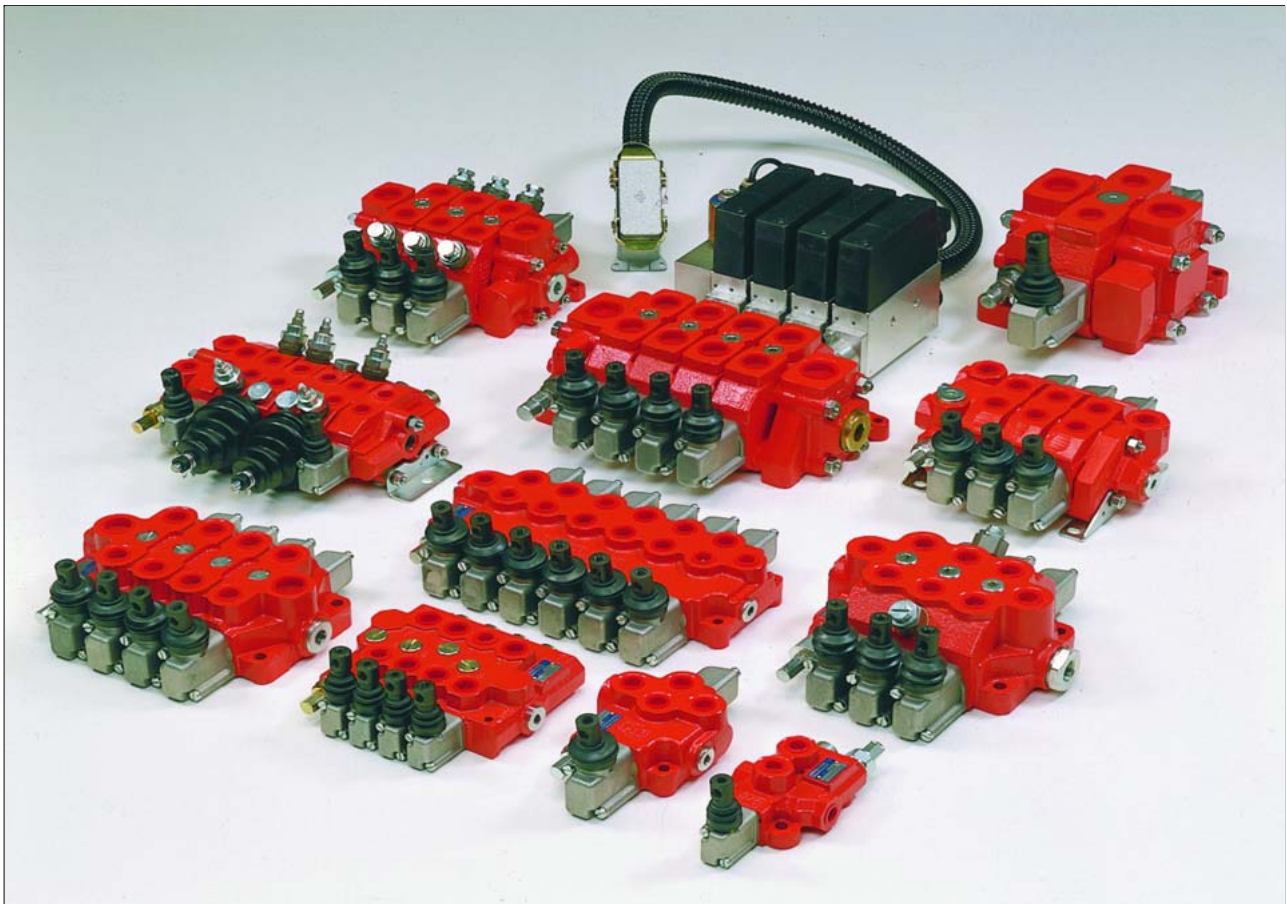

motion and progress

### 3 Monobloc directional control valves HDM11P



#### Contents

3.1	General specifications	19
3.2	Dimensional data	20
3.3	Performances curves	21
3.4	Adjustable Direct Acting - Relief Valve RV	22
3.5	Monobloc bodies	22
3.6	Spool charts	24
3.7	Schemes	24
3.8	Spool positioners	24
3.9	Lever styles	28

### 3.1 General specifications

Technical specification		
Max flow rate	l/min U.S.G.P.M.	45 12
Max continuous operating pressure supply port P	bar PSI	250 3600
Max intermittent peak pressure Work port A/B	bar PSI	320 4600
Max back pressure	bar PSI	30 430
Oil temperature	° C ° F	-10 to 80 14 to 180
Oil viscosity	mm <sup>2</sup> /s	16 to 75
Oil filtration	μ	≤ 30

Spool leakage at 100 bar (1450 PSI), Temp. 50° C (120° F), viscosity 27 mm <sup>2</sup> /s:		
Maximum	cm <sup>3</sup> /min Cu. In./min	12 0.732
Middle	cm <sup>3</sup> /min Cu. In./min	6 0.366
Lower values on demand (to be agreed with our Sales Dept..)		

Number of spools	2 to 6
Adjustable direct operated relief valve (tamper-proof seal available on request)	RV
Single load hold check valve	LC

#### 3.1.1 Weight (standard version without options)

Version	kg	lb
HDM11P/2	4	8.81
HDM11P/3	5.20	11.45
HDM11P/4	6.40	14.10
HDM11P/5	7.60	16.74
HDM11P/6	8.80	19.38

#### 3.1.2 Material specification:

Body: High strength cast-iron.  
Spool: Hardened steel and chrome plated  
Seals: Buna "N".

#### 3.1.3 Standard features:

- 1) Parallel circuit
- 2) Balanced interchangeable spools (provides minimum leakage, smooth operation)
- 3) Wide selections inlets, work ports, and outlets threaded ports.
- 4) Negative overlapping of the spool.

#### 3.1.4 Optional features available:

- 1) Open or closed centre positions, 3 or 4 way operations, 3 or 4 position (float position), full open centre (motoring spool) and other spool options.
- 2) Carry over.
- 3) Complete lever assembly
- 4) Wide range of positioners

#### 3.1.5 Symbols:

**P**: inlet port  
**T**: outlet port  
**A/B**: work ports  
**H.P.C.O.**: carry-over  
**RV**: relief valve  
**P<sub>1</sub>T<sub>1</sub>**: top inlet and outlet ports  
**P<sub>2</sub>**: side inlet  
**T<sub>2</sub>**: side outlet  
 3.1.0.2: spool position  
 P: pressure line  
 T : exhaust line  
 E: centre line (by pass).



### 3.3 Performance curves

Oil: Shell Tellus T37  
 Temperature: 50° C (120° F)  
 Viscosity: 27 mm<sup>2</sup>/s

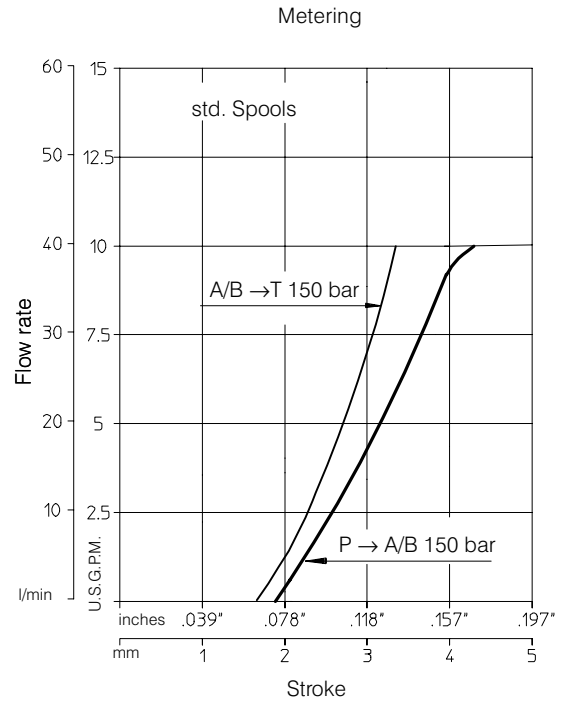
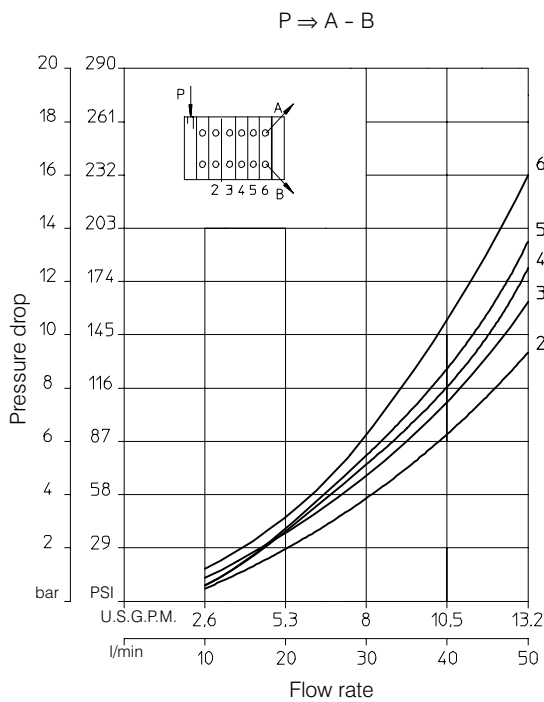
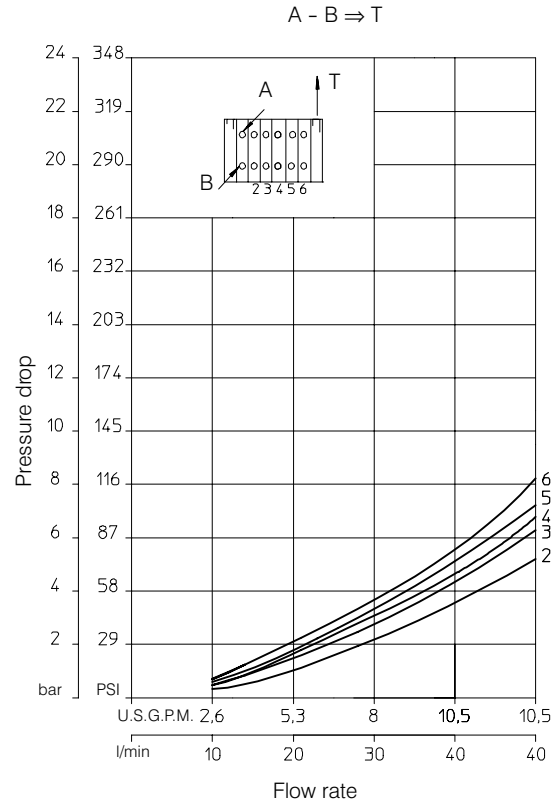
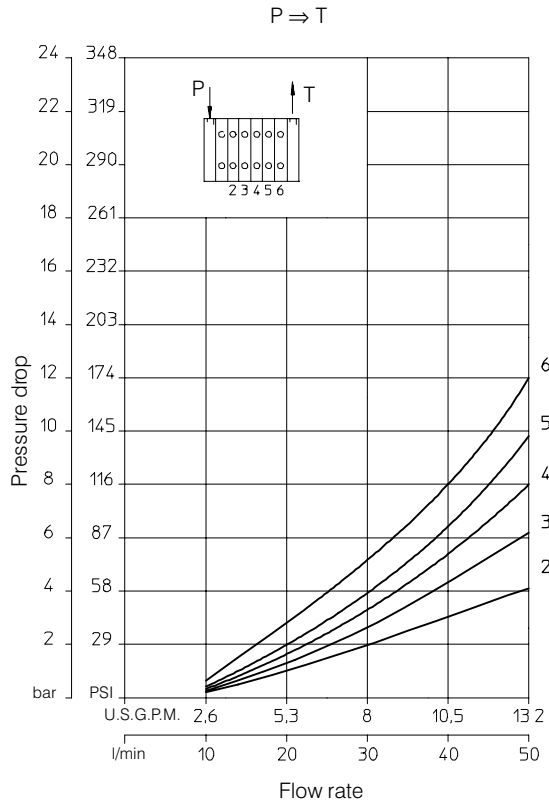

### 3.4 Adjustable direct acting Relief Valve RV

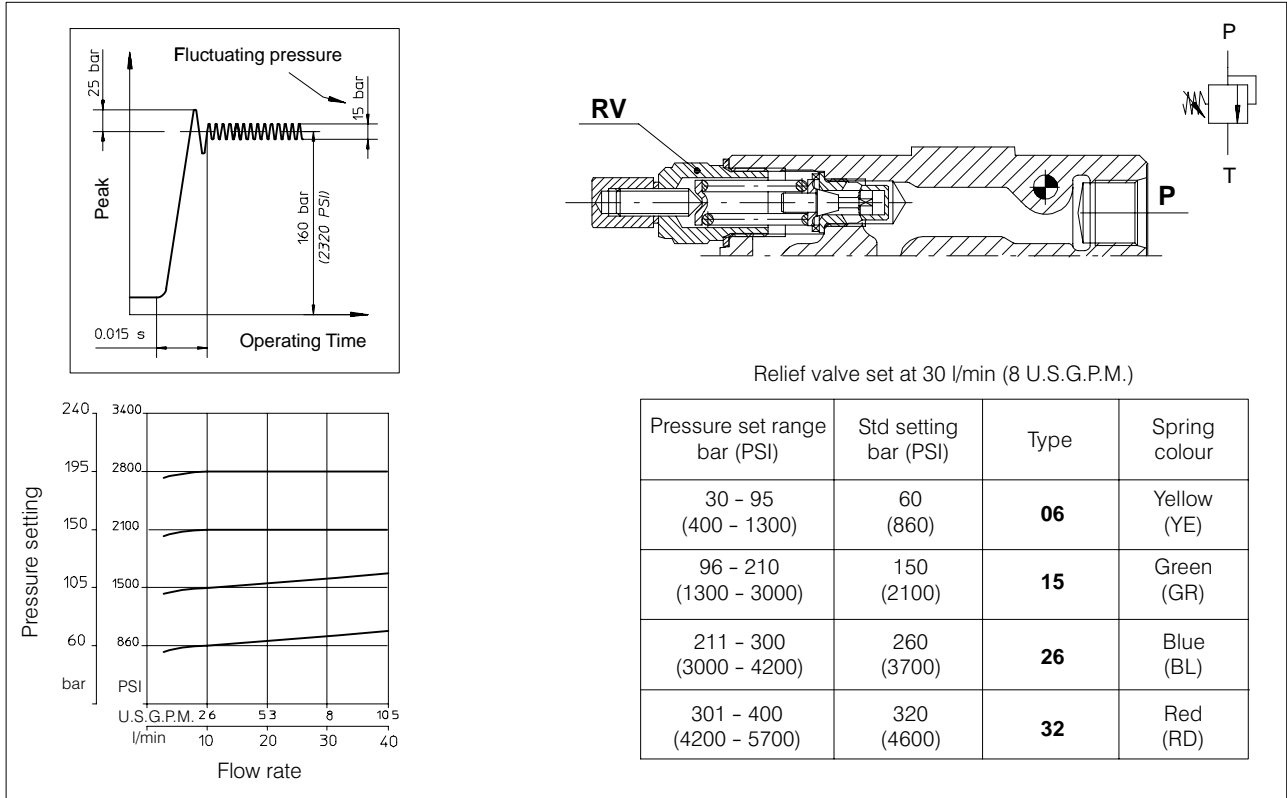

### 3.5 Monobloc bodies

#### 3.5.1 Open center with P – T – RV (Standard)

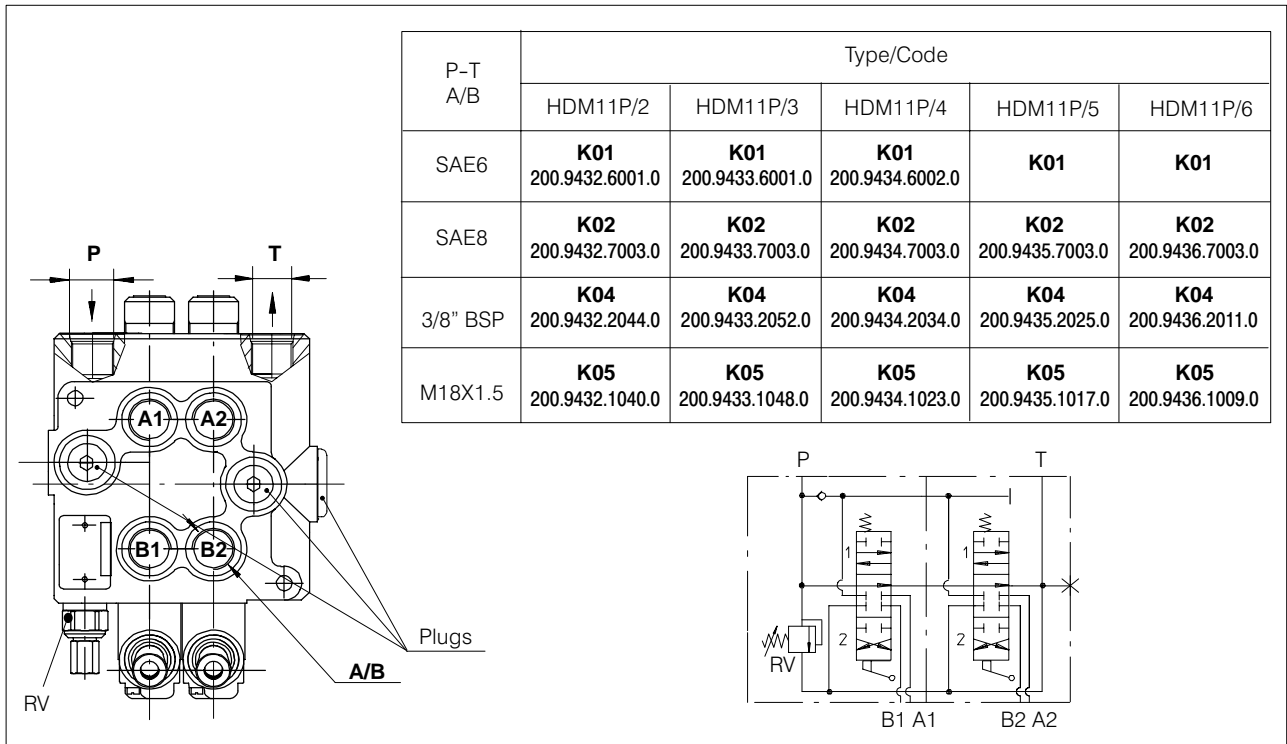

Note 1: Body codes consist of: machined casting, seals, plugs and check valve only. Not to be used for complete valve order.

Note 2: For availability of -K- bodies without code please contact our Sales Department.

3.5.2 Power beyond with P – T – RV – H.P.C.O.

P-T A/B H.P.C.O.	Type/Code				
	HDM11P/2	HDM11P/3	HDM11P/4	HDM11P/5	HDM11P/6
SAE6	<b>K11</b> 200.9432.6002.0	<b>K11</b> 200.9433.6002.0	<b>K11</b> 200.9434.6003.0	<b>K11</b>	<b>K11</b>
SAE8	<b>K12</b> 200.9432.7004.0	<b>K12</b> 200.9433.7004.0	<b>K12</b> 200.9434.7004.0	<b>K12</b> 200.9435.7004.0	<b>K12</b> 200.9436.7004.0
3/8" BSP	<b>K14</b> 200.9432.2045.0	<b>K14</b> 200.9433.2053.0	<b>K14</b> 200.9434.2035.0	<b>K14</b> 200.9435.2026.0	<b>K14</b> 200.9436.2012.0
M18X1.5	<b>K15</b> 200.9432.1041.0	<b>K15</b> 200.9433.1049.0	<b>K15</b> 200.9434.1024.0	<b>K15</b> 200.9435.1018.0	<b>K15</b> 200.9436.1010.0

3.5.3 Closed center with P – T – RV

P-T A/B	Type/Code				
	HDM11P/2	HDM11P/3	HDM11P/4	HDM11P/5	HDM11P/6
SAE6	<b>K21</b> 200.9432.6003.0	<b>K21</b> 200.9433.6003.0	<b>K21</b> 200.9434.6004.0	<b>K21</b>	<b>K21</b>
SAE8	<b>K22</b> 200.9432.7005.0	<b>K22</b> 200.9433.7005.0	<b>K22</b> 200.9434.7005.0	<b>K22</b> 200.9435.7005.0	<b>K22</b> 200.9436.7005.0
3/8" BSP	<b>K24</b> 200.9432.2043.0	<b>K24</b> 200.9433.2051.0	<b>K24</b> 200.9434.2033.0	<b>K24</b> 200.9435.2024.0	<b>K24</b> 200.9436.2013.0
M18X1.5	<b>K25</b> 200.9432.1042.0	<b>K25</b> 200.9433.1050.0	<b>K25</b> 200.9434.1025.0	<b>K25</b> 200.9435.1019.0	<b>K25</b> 200.9436.1011.0

Note 1: Body codes consist of: machined casting, seals, plugs and check valve only. Not to be used for complete valve order.

Note 2: For availability of -K- bodies without code please contact our Sales Department.

### 3.6 Spool charts

Spool scheme	Spool features	Type
	4 way - 3 position A/B closed E open by pass	<b>A</b>
	High metering spool (max flow suggested 15 l/min.)	<b>AS</b>
	4 way - 3 position A/B-E closed	<b>B</b>
	4 way - 3 position A/B to tank in neutral E open by pass	<b>C</b>
	3 way - 3 position B closed E open by pass	<b>G</b>
	3 way - 3 position A closed E open by pass	<b>S</b>

	4 way - 4 position 4 <sup>th</sup> floating position	<b>Z</b>
	4 way - 4 position 4 <sup>th</sup> floating position	<b>* WW</b>
	4 way - 3 position with regenerative spool in 2 <sup>nd</sup> position	<b>R**</b>
	4 way - 3 position A closed B $\rightarrow$ T E open by pass	<b>DP</b>
	4 way - 3 position A to tank in neutral B closed E open by pass	<b>LP</b>

\*: "WW" spool requires: special body (K...), positioner (240) and lever (L192)

\*\* : special body required (please contact our Sales Dept.)

### 3.7 Schemes

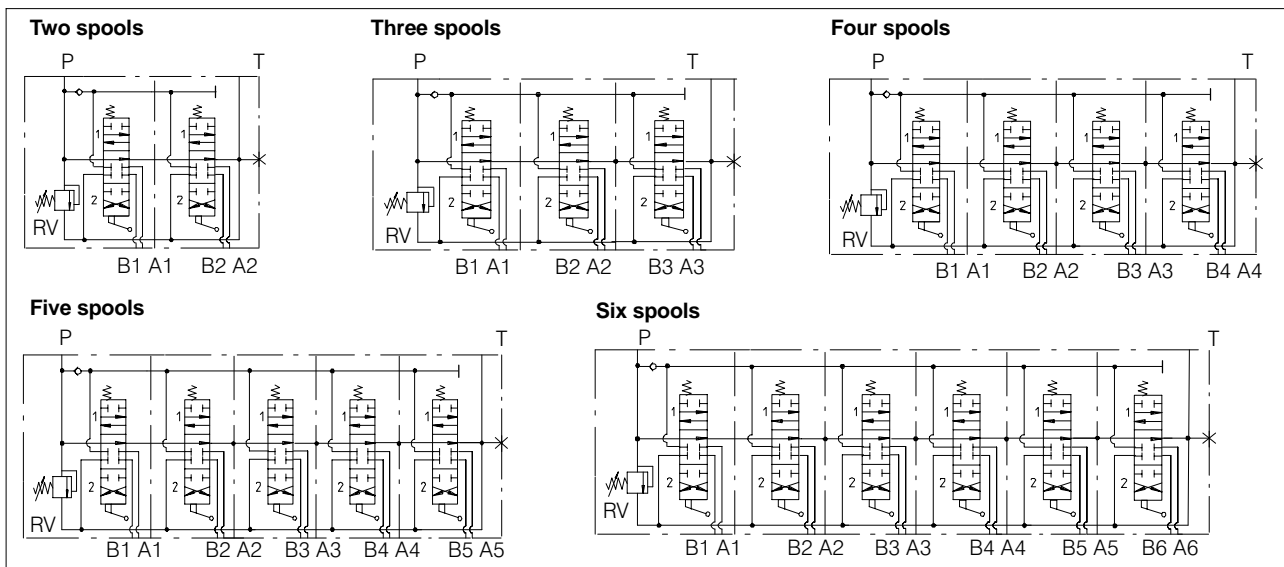

### 3.8 Spool positioners

F (N)**	Type	Code*
200	<b>01</b> standard	200.7685.1001.0
140	<b>79</b>	200.7685.1092.0

3 position spring return to neutral

Type	Code*
<b>02</b>	200.7685.3001.0

2 position detent - spring center

\* : code without plastic plug; plastic plug code: 200.6780.0008.0  
Code F (N)\*\*: force in Newton (N) needed to operate the spool



Type <b>03</b>	Code* 200.7685.2001.0
-------------------	--------------------------

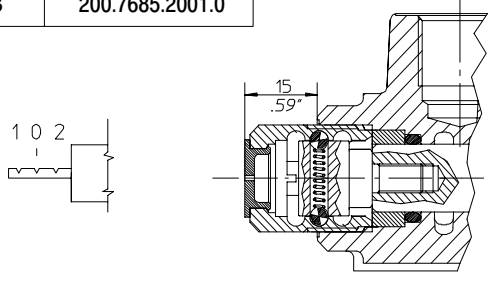

3 position detent

Type <b>04</b>	Code 200.7685.4003.0
-------------------	-------------------------

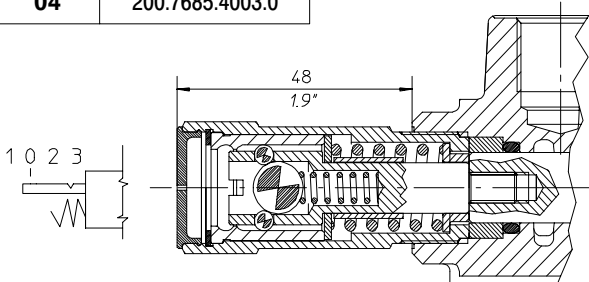

4 position float Plastic plug code: 200.6780.0009.0

Type <b>05</b>	Code* 200.7685.2005.0
-------------------	--------------------------

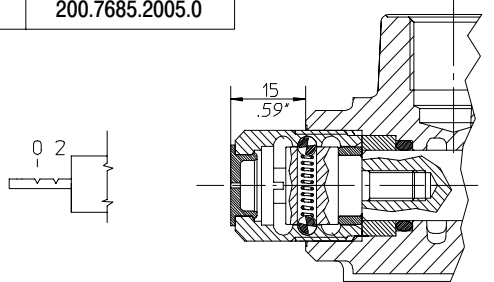

2 position detent

Type <b>06</b>	Code* 200.7685.1005.0
-------------------	--------------------------

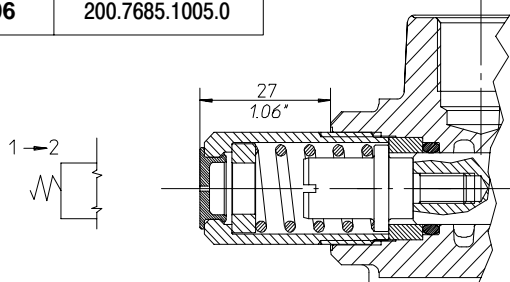

2 position spring return

Type <b>07</b>	Code* 200.7685.2027.0
-------------------	--------------------------

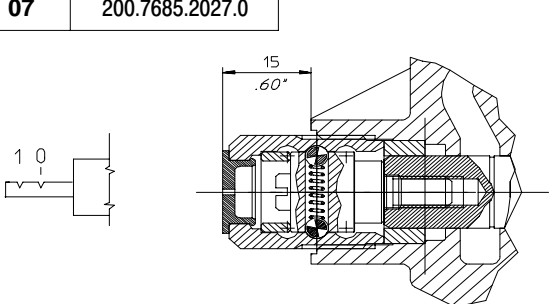

2 position detent

Type <b>12</b>	Code* 200.7685.1021.0
-------------------	--------------------------

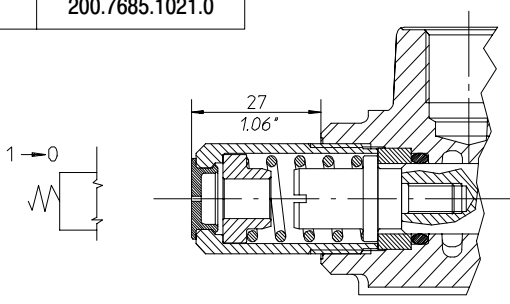

2 position spring return

Type <b>15</b>	Code* 200.7685.1109.0
-------------------	--------------------------

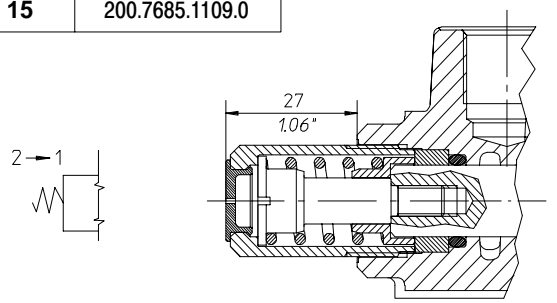

2 position spring return

Type <b>16</b>	Code* 200.7685.1110.0
-------------------	--------------------------

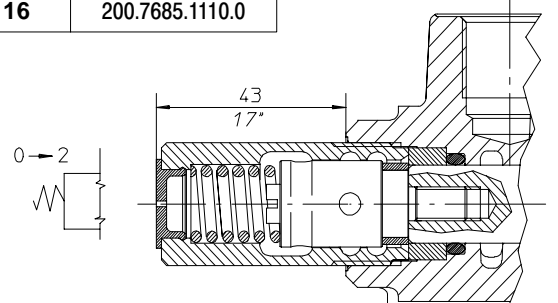

2 position spring return to neutral

\* : code without plastic plug; plastic plug code: 200.6780.0008.0

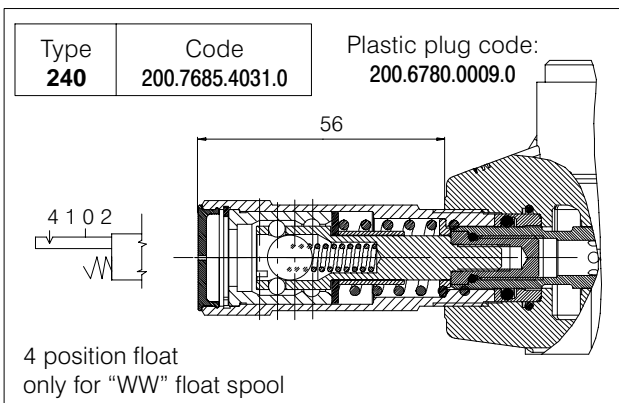
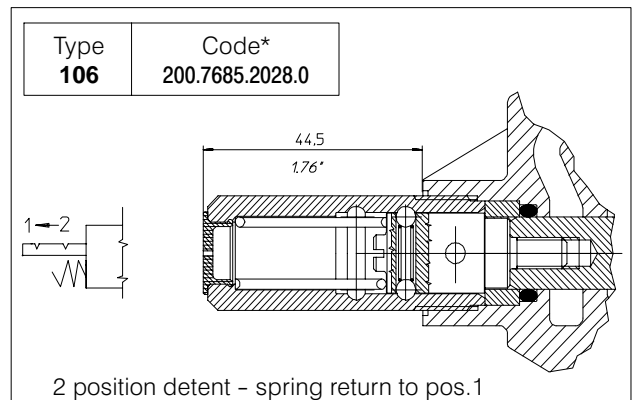
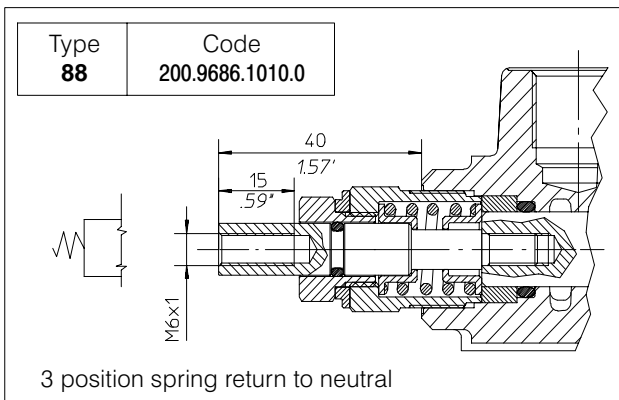
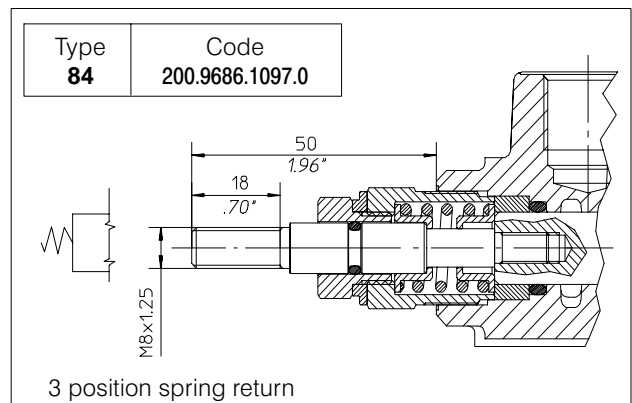
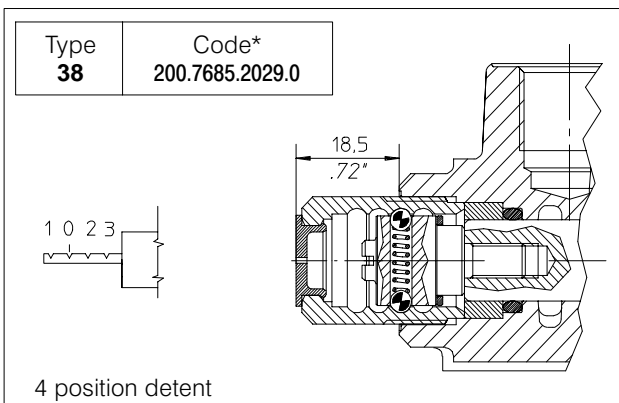
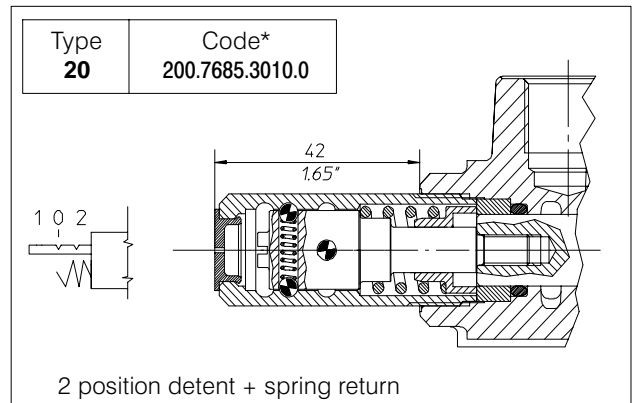
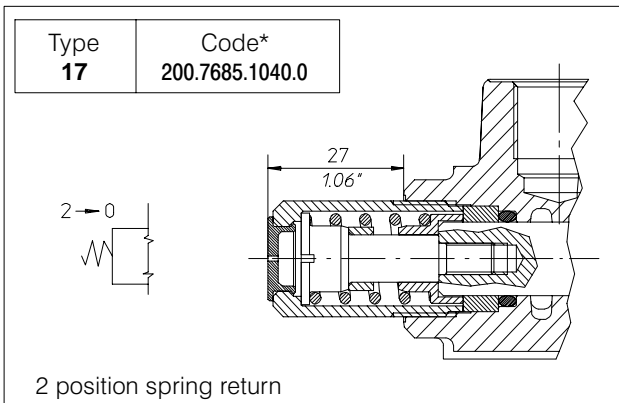

\* : code without plastic plug; plastic plug code: 200.6780.0008.0

3.8.1 Microswitch control on each single element

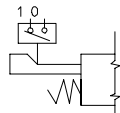
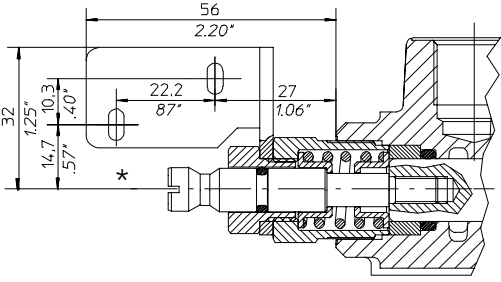
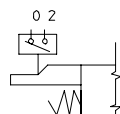
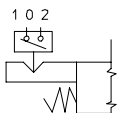
Type <b>30</b>	Code 200.9686.1050.0	Microswitch is operated when the spool is in pos. 1		
Type <b>32</b>	Code 200.9686.1060.0	Microswitch is operated when the spool is in pos. 2		
Type <b>34</b>	Code 200.9686.1064.0	Microswitch is operated when the spool is in pos. 1 and 2		

\* The microswitch is supplied only on customer's request

3.8.2 Single microswitch control for multi-sectional valves (from 1<sup>st</sup> up to second-last element).

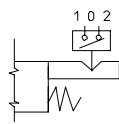
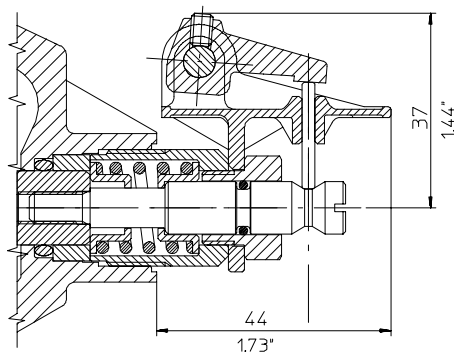
Type <b>39 (MSF)</b>	Code 200.9686.1139.0	Microswitch is operated when the spool is in pos. 1 and 2		
-------------------------	-------------------------	---	---	--

3.8.3 Single microswitch control for multi-sectional valves (last element, T side).

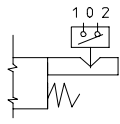
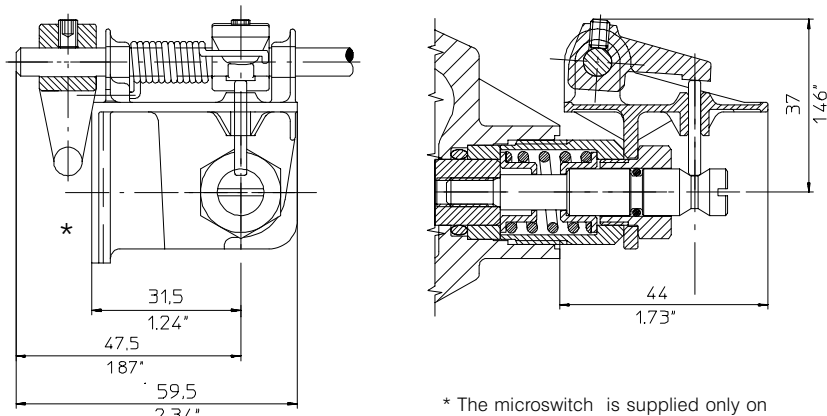
Type <b>40 (MFL)</b>	Code 200.9686.1140.0	Microswitch is operated when the spool is in pos. 1 and 2		
-------------------------	-------------------------	---	---	--

\* The microswitch is supplied only on customer's request.

1 - Positioner 40 must be assembled only on the last element near T port  
 2 - Positioner 40 require T port plugged. Use T1 or T2 ports

### 3.9 Lever styles

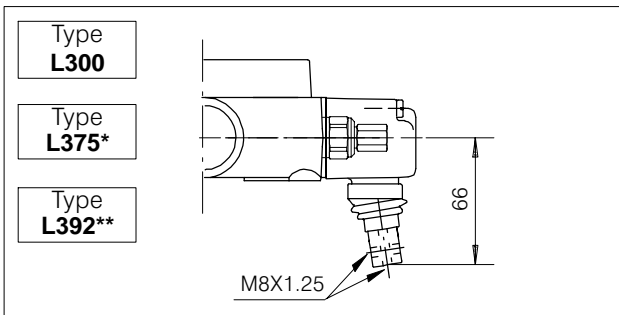
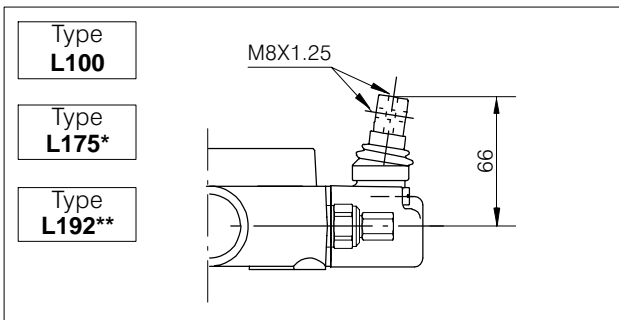
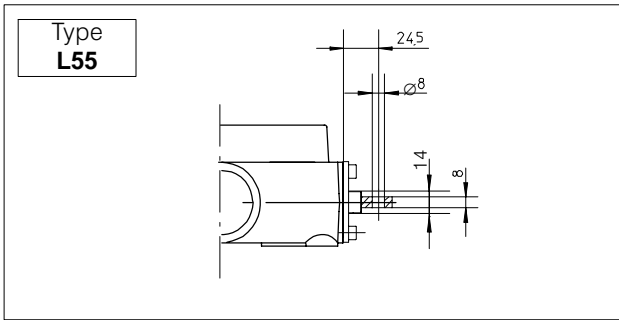

Lo		Type	Code
mm	inches		
150	5.90	<b>AL001</b>	200.7022.1019.0
200	7.87	<b>AL002</b>	200.7022.1003.0
250	9.84	<b>AL003</b>	200.7022.1005.0
300	11.81	<b>AL004</b>	200.7022.1006.0

\* L175 - L375 only for "Z" spool application

\*\* L192 - L392 only for "WW" spool application

#### 3.9.1 Safety levers

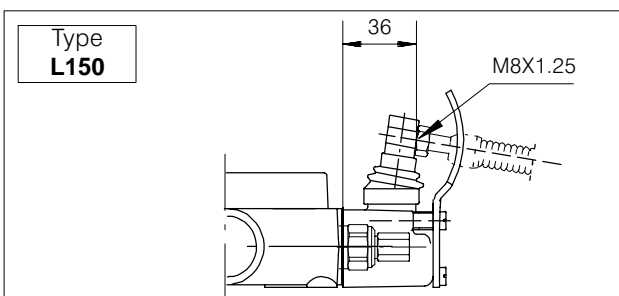
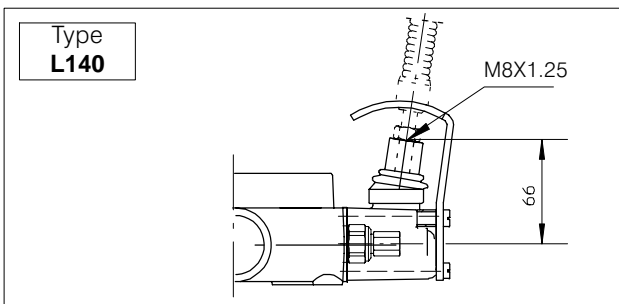

Lo		Type	Code
mm	inches		
160	6.30	<b>AL014</b>	200.7022.1009.0
180	7.08	<b>AL018</b>	200.7022.1011.0

3.9.2 Remote cable control

<b>Lever Support</b>	Code 200.7609.0013.0
----------------------	-------------------------

M10X1.5

Optional 200.6772.0048.0

Lo		Type	Code
mm	inches		
185	7.28	<b>AL001</b>	200.7022.2001.0
250	9.84	<b>AL002</b>	200.7022.2003.0
300	11.81	<b>AL003</b>	200.7022.2004.0
350	13.78	<b>AL004</b>	200.7022.2005.0

<b>Cable</b>	Cable length	Code
--------------	--------------	------

1000 mm	200.5441.04002
1500 mm	200.5441.04005
2000 mm	200.5441.04006
2500 mm	200.5441.04007
3000 mm	200.5441.04008
4000 mm	200.5441.04009

Cables are assembled on the valve only on request and with an extra charge.

<b>Spool Kit</b>	Code 200.9609.0037.0 200.9609.0039.0*
------------------	---

\* only for "Z" spool application

Type <b>L142</b>	Code 200.7071.2012.0
---------------------	-------------------------

M10X1.5

122  
4.8"

42  
1.65"

M8x1.25

150  
5.9"

35  
1.38"

40  
1.57"

68  
2.68"

40  
1.57"

35

Optional 200.6772.0048.0

Only for rod remote control

Type <b>L135</b>	Code 200.9759.2020.0	No rubber boot protection is available for L135
---------------------	-------------------------	---

View from X

Fulcrum

A<sub>1</sub>, A<sub>2</sub>, B<sub>1</sub>, B<sub>2</sub>

Fulcrum

X

P, 1, 2, T

RV

X

M10X1.5

3.9.3 Cross joystick for dual axis spool control

Type <b>AL038</b>	Code 200.7022.2018.0
----------------------	-------------------------

Lo=200

M10X1.5

## **BUCHER HYDRAULICS**

[www.bucherhydraulics.com](http://www.bucherhydraulics.com)

### **Germany**

Phone +49 7742 85 20  
Fax +49 7742 71 16  
[info.de@bucherhydraulics.com](mailto:info.de@bucherhydraulics.com)

### **France**

Phone +33 389 64 22 44  
Fax +33 389 65 28 78  
[info.fr@bucherhydraulics.com](mailto:info.fr@bucherhydraulics.com)

### **Netherlands**

Phone +31 79 34 26 24 4  
Fax +31 79 34 26 28 8  
[info.nl@bucherhydraulics.com](mailto:info.nl@bucherhydraulics.com)

### **UK**

Phone +44 24 76 35 35 61  
Fax +44 24 76 35 35 72  
[info.uk@bucherhydraulics.com](mailto:info.uk@bucherhydraulics.com)

### **USA**

Phone +1 262 605 82 80  
Fax +1 262 605 82 78  
[info.wi@bucherhydraulics.com](mailto:info.wi@bucherhydraulics.com)

### **Switzerland**

Phone +41 33 67 26 11 1  
Fax +41 33 67 26 10 3  
[info.ch@bucherhydraulics.com](mailto:info.ch@bucherhydraulics.com)

### **Italy**

Phone +39 0522 92 84 11  
Fax +39 0522 51 32 11  
[info.it@bucherhydraulics.com](mailto:info.it@bucherhydraulics.com)

### **Austria**

Phone +43 6216 44 97  
Fax +43 6216 44 97 4  
[info.at@bucherhydraulics.com](mailto:info.at@bucherhydraulics.com)

### **China**

Phone +86 10 64 44 32 38  
Fax +86 10 64 44 32 35  
[info.bj@bucherhydraulics.com](mailto:info.bj@bucherhydraulics.com)

### **Product Center (Elevator)**

Phone +41 41 757 03 33  
Fax +41 41 755 16 49  
[info.nh@bucherhydraulics.com](mailto:info.nh@bucherhydraulics.com)

We reserve the right of modification without prior notice.