

MASSIVE SAVINGS!

**Everything Hydraulic**

# FLOWFIT®

MANUFACTURERS AND SUPPLIERS OF  
HYDRAULIC COMPONENTS & SYSTEMS

**HYDRAULIC HOSES,  
FITTINGS AND  
MACHINERY  
CATALOGUE**



**CALL**  
01584 876033



**CLICK**  
[www.flowfitonline.com](http://www.flowfitonline.com)



**VISIT**  
Open 6 days a week

# FLOWFIT®

Welcome to the brand new **FLOWFIT HYDRAULIC HOSE, FITTINGS, AND MACHINERY CATALOGUE!**

Offering a wide range of different sizes and variations of high quality hydraulic hose and fittings. Additionally, a collection of different hose crimping and cutting machines to suit your needs and requirements.

All products also available at [flowfitonline.com](http://flowfitonline.com)

### FLOWFIT® MANUFACTURERS AND SUPPLIERS OF HYDRAULIC COMPONENTS

#### JIC SWEPT 90° SWIVEL FEMALE

**Product Code: VHS01**

REF.	HOSE DIAMETER	THREAD SIZE	NETT. PRICE	
			€ STERLING	€ EURO
HJ-F168002CF	1/4"	7/16" JIC 90°	€1.06	€1.18
HJ-F168004CF	1/4"	1/2" JIC 90°	€1.46	€1.61
HJ-F168006CF	1/4"	9/16" JIC 90°	€1.46	€1.61
HJ-F168008CF	1/4"	7/8" JIC 90°	€1.16	€1.28
HJ-F168010CF	3/8"	9/16" JIC 90°	€1.46	€1.61
HJ-F168012CF	3/8"	3/4" JIC 90°	€1.46	€1.61
HJ-F168014CF	3/8"	7/8" JIC 90°	€2.72	€3.07
HJ-F168016CF	1/2"	3/4" JIC 90°	€2.02	€2.29
HJ-F168018CF	1/2"	7/8" JIC 90°	€2.96	€3.36
HJ-F168020CF	1/2"	1 1/16" JIC 90°	€3.34	€3.71
HJ-F168022CF	5/8"	7/8" JIC 90°	€3.30	€3.68
HJ-F168024CF	5/8"	1 1/16" JIC 90°	€3.68	€4.16
HJ-F168026CF	3/4"	1 5/16" JIC 90°	€3.72	€4.20
HJ-F168028CF	3/4"	1 3/8" JIC 90°	€3.36	€3.81
HJ-F168030CF	3/4"	1 5/8" JIC 90°	€3.96	€4.56
HJ-F168032CF	1"	1 5/8" JIC 90°	€3.30	€3.72
HJ-F168034CF	1" 1/4	1 7/8" JIC 90°	€19.42	€21.87
HJ-F168036CF	1" 1/2	1" 7/8" JIC 90°	€13.02	€14.88
HJ-F168038CF	2"	2" 1/2" JIC 90°	€73.34	€83.63

### Metric Fittings

#### METRIC STRAIGHT SWIVEL FEMALE

**Product Code: VHS01**

REF.	HOSE DIAMETER	THREAD SIZE	NETT. PRICE	
			€ STERLING	€ EURO
M18-402F	1/4"	M12 x 1.5 METRIC STRAIGHT	€1.02	€1.15
M18-402F	1/4"	M14 x 1.5 METRIC STRAIGHT	€1.02	€1.15
M18-402F	1/4"	M16 x 1.5 METRIC STRAIGHT	€3.02	€3.40
M18-402F	1/4"	M18 x 1.5 METRIC STRAIGHT	€1.00	€1.13
M18-402F	3/8"	M16 x 1.5 METRIC STRAIGHT	€1.16	€1.31
M18-402F	3/8"	M18 x 1.5 METRIC STRAIGHT	€1.10	€1.24
M18-402F	3/8"	M22 x 1.5 METRIC STRAIGHT	€1.42	€1.60
M18-402F	1/2"	M22 x 1.5 METRIC STRAIGHT	€1.30	€1.49
M18-402F	1/2"	M26 x 1.5 METRIC STRAIGHT	€3.30	€3.75
M18-402F	5/8"	M26 x 1.5 METRIC STRAIGHT	€1.40	€1.58
M18-402F	3/4"	M30 x 1.5 METRIC STRAIGHT	€2.50	€2.83
M18-402F	1"	M30 x 2 METRIC STRAIGHT	€2.32	€2.62
M18-402F	1"	M36 x 2 METRIC STRAIGHT	€5.20	€5.98

#### JIC STUD MALE

**Product Code: VHS01**

REF.	HOSE DIAMETER	THREAD SIZE	NETT. PRICE	
			€ STERLING	€ EURO
JM164CF	1/4"	7/16" JIC STUD	€1.21	€1.36
JM164CF	1/4"	1/2" JIC STUD	€1.46	€1.61
JM164CF	1/4"	9/16" JIC STUD	€3.50	€3.97
JM164CF	1/4"	7/8" JIC STUD	€1.10	€1.25
JM164CF	3/8"	9/16" JIC STUD	€1.10	€1.25
JM164CF	3/8"	3/4" JIC STUD	€1.10	€1.25
JM164CF	3/8"	7/8" JIC STUD	€1.10	€1.25
JM164CF	1/2"	3/4" JIC STUD	€2.10	€2.37
JM164CF	1/2"	7/8" JIC STUD	€2.40	€2.71
JM164CF	1/2"	1 1/16" JIC STUD	€2.40	€2.71
JM164CF	5/8"	7/8" JIC STUD	€2.10	€2.37
JM164CF	5/8"	1 1/16" JIC STUD	€2.40	€2.71
JM164CF	3/4"	1 1/16" JIC STUD	€1.10	€1.25
JM164CF	3/4"	1 3/8" JIC STUD	€1.10	€1.25
JM164CF	1"	1 5/8" JIC STUD	€3.40	€3.89
JM164CF	1"	1 7/8" JIC STUD	€2.40	€2.71
JM164CF	1" 1/4	1 7/8" JIC STUD	€20.34	€23.19
JM164CF	2"	2" 1/2" JIC STUD		

#### METRIC 45° SWIVEL FEMALE

**Product Code: VHS01**

REF.	HOSE DIAMETER	THREAD SIZE	NETT. PRICE	
			€ STERLING	€ EURO
M18-452F	1/4"	M12 x 1.5 METRIC 45°	€1.24	€1.40
M18-452F	1/4"	M14 x 1.5 METRIC 45°	€1.42	€1.60
M18-452F	1/4"	M16 x 1.5 METRIC 45°	€1.42	€1.60
M18-452F	3/8"	M16 x 1.5 METRIC 45°	€1.60	€1.80
M18-452F	3/8"	M18 x 1.5 METRIC 45°	€1.70	€1.92
M18-452F	1/2"	M22 x 1.5 METRIC 45°	€2.18	€2.48
M18-452F	1/2"	M26 x 1.5 METRIC 45°	€2.72	€3.07
M18-452F	5/8"	M26 x 2 METRIC 45°	€4.30	€4.86
M18-452F	1" 1/4	M36 x 2 METRIC 45°	€8.70	€9.83
M18-452F	1" 1/2	M42 x 2 METRIC 45°	€14.18	€16.02
M18-452F	1" 1/2	M52 x 2 METRIC 45°	€21.50	€24.30

#### JIC STUD MALE

**Product Code: VHS01**

REF.	HOSE DIAMETER	THREAD SIZE	NETT. PRICE	
			€ STERLING	€ EURO
JM164CF	1/4"	7/16" JIC STUD	€1.21	€1.36
JM164CF	1/4"	1/2" JIC STUD	€1.46	€1.61
JM164CF	1/4"	9/16" JIC STUD	€3.50	€3.97
JM164CF	1/4"	7/8" JIC STUD	€1.10	€1.25
JM164CF	3/8"	9/16" JIC STUD	€1.10	€1.25
JM164CF	3/8"	3/4" JIC STUD	€1.10	€1.25
JM164CF	3/8"	7/8" JIC STUD	€1.10	€1.25
JM164CF	1/2"	3/4" JIC STUD	€2.10	€2.37
JM164CF	1/2"	7/8" JIC STUD	€2.40	€2.71
JM164CF	1/2"	1 1/16" JIC STUD	€2.40	€2.71
JM164CF	5/8"	7/8" JIC STUD	€2.10	€2.37
JM164CF	5/8"	1 1/16" JIC STUD	€2.40	€2.71
JM164CF	3/4"	1 1/16" JIC STUD	€1.10	€1.25
JM164CF	3/4"	1 3/8" JIC STUD	€1.10	€1.25
JM164CF	1"	1 5/8" JIC STUD	€3.40	€3.89
JM164CF	1"	1 7/8" JIC STUD	€2.40	€2.71
JM164CF	1" 1/4	1 7/8" JIC STUD	€20.34	€23.19
JM164CF	2"	2" 1/2" JIC STUD		

#### METRIC SWEEP 90° SWIVEL FEMALE

**Product Code: VHS01**

REF.	HOSE DIAMETER	THREAD SIZE	NETT. PRICE	
			€ STERLING	€ EURO
M18-902F	1/4"	M12 x 1.5 METRIC 90°	€1.15	€1.31
M18-902F	1/4"	M14 x 1.5 METRIC 90°	€1.35	€1.54
M18-902F	1/4"	M16 x 1.5 METRIC 90°	€1.36	€1.54
M18-902F	3/8"	M16 x 1.5 METRIC 90°	€1.40	€1.58
M18-902F	3/8"	M18 x 1.5 METRIC 90°	€1.54	€1.75
M18-902F	1/2"	M22 x 1.5 METRIC 90°	€1.64	€1.86
M18-902F	1/2"	M26 x 1.5 METRIC 90°	€2.08	€2.35
M18-902F	5/8"	M26 x 1.5 METRIC 90°	€2.42	€2.76
M18-902F	3/4"	M30 x 1.5 METRIC 90°	€2.62	€2.99
M18-902F	1"	M30 x 2 METRIC 90°	€4.14	€4.68
M18-902F	1" 1/4	M36 x 2 METRIC 90°	€7.94	€8.97
M18-902F	1" 1/2	M42 x 2 METRIC 90°	€13.62	€15.39
M18-902F	1" 1/2	M52 x 2 METRIC 90°	€20.96	€23.35

**100% SECURE SHOPPING**

**HASSLE FREE DELIVERY DIRECT TO YOUR DOOR**

**NO QUIBBLE GUARANTEE**

**24 HOUR SHOPPING**

**UK BASED CALL CENTRE**

Contact us  
for your **FREE**  
copy of our  
**FULL**  
**580 PAGE**  
**CATALOGUE**  
containing  
**EVERYTHING**  
**HYDRAULIC!**



# FLOWFIT<sup>®</sup>

## HYDRAULIC HOSE, FITTINGS AND MACHINERY

PAGE  
**6**



HYDRAULIC  
HOSE

PAGE  
**7**



BSP  
FITTINGS

PAGE  
**9**



JIC  
FITTINGS

PAGE  
**11**



METRIC  
FITTINGS

PAGE  
**12**



HOSE  
PROTECTION

PAGE  
**13**



HAND  
HOSE CRIMPERS

PAGE  
**16**



WORKSHOP  
HOSE CRIMPERS

PAGE  
**22**



**ACCESSORIES FOR  
HOSE CRIMPERS**

PAGE  
**23**



**MOBILE VAN  
SOLUTIONS**

PAGE  
**26**



**PRODUCTION HOSE  
CRIMPERS**

PAGE  
**27**

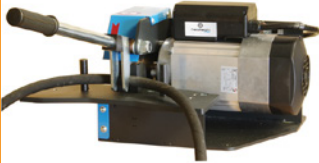

**HOSE  
CUTTERS**

PAGE  
**30**



**HOSE  
SKIVING**

PAGE  
**33**



**PERIPHERALS**

PAGE  
**34**



**HOSE AND TUBE  
CLEANING**

PAGE  
**35**



**ALSO  
AVAILABLE**

PAGE  
**36**



**HOSE  
CRIMPER KITS**

# HOW TO ORDER



**Phone: 01584 876033**

Monday - Thursday 8.30am - 5.00pm

Friday 8.00am - 4.00pm

Saturday 8.00am - 12.30pm



**Email: sales@flowfitonline.com**

You can email your order to our fully qualified sales team 24 hours a day, 7 days a week



**By Mail**

Harrier Fluid Power Ltd T/A Flowfit  
Parys Road, Ludlow Business Park  
Ludlow, Shropshire SY8 1XY



**Online: www.flowfitonline.com**

Online ordering is the quickest and most convenient way to all the industrial supplies you need, 24 hours a day, 7 days a week.



**Fax: 01584 876044**

**Fax orders, 24/7**



**Visit our Trade Counter in Ludlow**  
Parys Road, Ludlow Business Park,  
Ludlow, Shropshire SY8 1XY

All prices in this catalogue are excluding V.A.T.

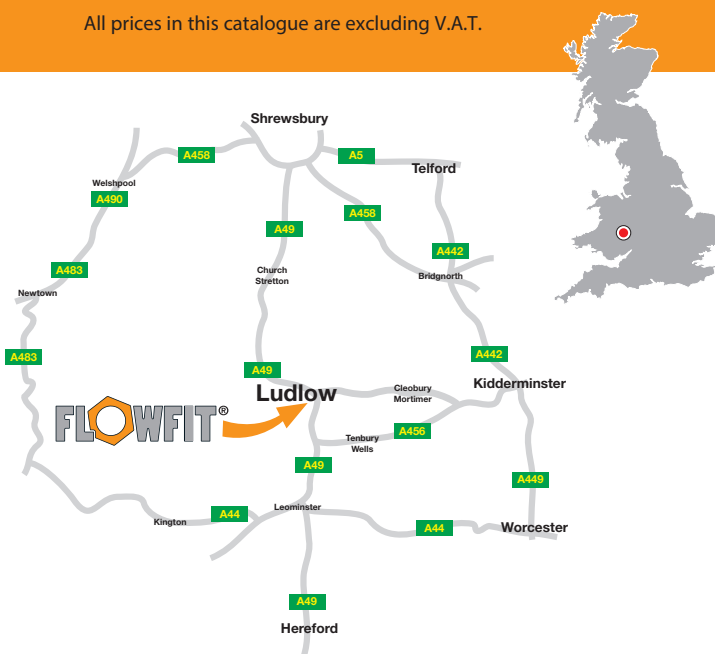

## Easy Payment Options

### Credit Account

Setting up a business credit account is quick and easy just fill out a credit form, downloadable from the website  
**www.flowfitonline.com**

### Other Payment Methods

For your convenience we have several easy payment options for you to choose from:

#### Credit & Debit Cards

#### Cash at our Trade Counter

#### BACS Transfers

#### Paypal Payments

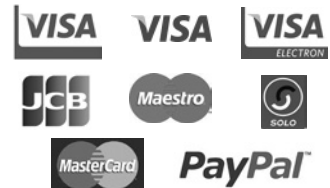

### Satisfaction Guarantee

In the unlikely event that you are not completely satisfied with your purchase, you can return your unused stock item for a full refund. Simply retain your original packaging and contact our Customer Services on 01584 876033 and we will arrange a free collection at a time that is convenient for you.



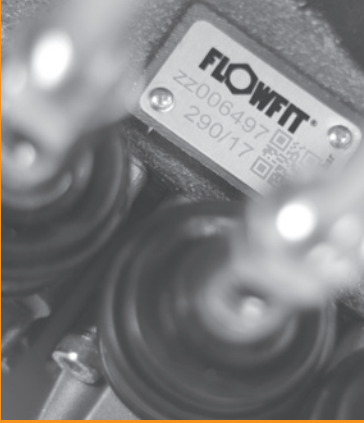

# DELIVERY

## Quality Products

Everything you buy from us is guaranteed for a minimum of 12 months. If during this time a manufacturers fault develops then we will either replace it free of charge or repair it. Please note all hydraulic powerunits are return to base. We are proud to be a QMS ISO 9002 Registered Firm.



## Free Advice

If you are not sure what you need or you can't find a particular product – call us we're here to help you. Our Technical Sales team is given the latest training and can source and advise the best products to suit your specific needs or we can design a system to suit with our in-house audited hydraulic engineers. We will also provide technical support and a free site visit to discuss your requirements.

## FREE NEXT DAY DELIVERY ON ALL WEB ORDERS

Orders placed over the phone or faxed will be subject to our standard delivery charges.

Order by 4.30pm for next day delivery throughout the UK.



### SPECIAL DELIVERY AVAILABLE

NEXT DAY BY 9.30am  
NEXT DAY BY 10.30am  
NEXT DAY BY 12 noon



### SAME DAY OR SATURDAY DELIVERY

Contact us for a quotation should you require this option.



### SHIP DIRECT

Use our stock to ship directly to your customers, no Flowfit paperwork, your paperwork sent direct with the goods.

### CALL US TODAY

Cross reference service  
Technical support  
Full hydraulic system design  
Price challenge  
Friendly staff, here to help 01584 876033

# Hydraulic Hose

## VINCKE STANDARD HOSE



**Medium-High Pressure** - Two Wire Braid Hydraulic Hose meets or exceeds DIN EN 853 2SN, SAE 100R2 AT and ISO 1436

VINCKE HH-22

www.flowfitonline.com  
TECH. DATA SHEET  
**VHS01**

		2SN									
PART NO.	NOMINAL Ø		INSIDE Ø	BRAID Ø	OUTSIDE Ø	BURST PRESSURE		MAX. WORKING PRESSURE		MINIMUM BEND RADIUS	PER METRE
	INCH	DASH SIZE	MM	MM	MM	BAR	PSI	BAR	PSI	MM	NETT. PRICE
HOSE-VNK-04	1/4"	04	6,4	12,8	15	1700	24650	400	5800	100	£2.25 € 2.54
HOSE-VNK-06	3/8"	06	9,5	16,7	18,9	1450	21025	330	4785	130	£2.98 € 3.37
HOSE-VNK-08	1/2"	08	12,7	19,8	22,2	1300	18850	275	3988	180	£3.59 € 4.06
HOSE-VNK-10	5/8"	10	16	22,9	25,2	1050	15225	250	3625	200	£4.88 € 5.51
HOSE-VNK-12	3/4"	12	19	26,9	29,2	960	13920	215	3118	240	£5.44 € 6.15
HOSE-VNK-16	1"	16	25,4	34,8	37,2	690	10005	165	2393	300	£6.81 € 7.70
HOSE-VNK-20	1 1/4"	20	31,8	44,3	47,3	500	7250	125	1813	420	£10.50 € 12.10
HOSE-VNK-24	1 1/2"	24	38,1	50,7	53,7	360	5220	90	1305	500	£12.00 € 13.83
HOSE-VNK-32	2"	32	50,8	63,5	66,7	320	4640	80	1160	630	£15.00 € 17.29

## VINCKE SMOOTH HOSE



**Medium-High Pressure** - Two Wire Braid Hydraulic Hose meets or exceeds EN857 2SC

VINCKE HH-24S

www.flowfitonline.com  
TECH. DATA SHEET  
**VHS01**

		2SN									
PART NO.	NOMINAL Ø		INSIDE Ø	BRAID Ø	OUTSIDE Ø	BURST PRESSURE		MAX. WORKING PRESSURE		MINIMUM BEND RADIUS	PER METRE
	INCH	DASH SIZE	MM	MM	MM	BAR	PSI	BAR	PSI	MM	NETT. PRICE
HOSE-SMVNK-04	1/4"	04	6,4	11,1	13,3	1680	24360	420	6090	50	£3.50 € 3.96
HOSE-SMVNK-06	3/8"	06	9,5	15	17,1	1400	20300	350	5075	65	£4.50 € 5.09
HOSE-SMVNK-08	1/2"	08	12,7	18,6	20,7	1240	17980	310	4495	90	£5.50 € 6.22
HOSE-SMVNK-10	5/8"	10	16	21,7	23,8	1120	16240	280	4060	100	£5.25 € 6.05
HOSE-SMVNK-12	3/4"	12	19	25,6	27,7	1080	15660	270	3915	120	£5.75 € 6.63
HOSE-SMVNK-16	1"	16	25,4	33,3	35,5	740	10730	185	2683	150	£7.25 € 8.36



## FERRULE 1SN 2SN 2SC 2SNK / 1SN 2SN 2SC 2SNK

www.flowfitonline.com  
TECH. DATA SHEET  
**VHS01**

REF.	HOSE DIAMETER	NETT. PRICE	
		£ STERLING	€ EUROS
FH-FER-04	1/4"	£0.49	€ 0.55
FH-FER-06	3/8"	£0.58	€ 0.65
FH-FER-08	1/2"	£0.71	€ 0.81
FH-FER-10	5/8"	£1.02	€ 1.16
FH-FER-12	3/4"	£1.24	€ 1.40
FH-FER-16	1"	£2.44	€ 2.75
FH-FER-20	1" 1/4	£5.12	€ 5.79
FH-FER-24	1" 1/2	£6.68	€ 7.55
FH-FER-32	2"	£10.25	€ 11.58



# BSP Fittings



## BSP STRAIGHT SWIVEL FEMALE

www.flowfitonline.com  
TECH. DATA SHEET  
**VHS01**

REF.	HOSE DIAMETER	THREAD SIZE	NETT. PRICE	
			£ STERLING	€ EUROS
HF0204CF	1/4"	1/8" BSPP Straight	£1.90	€ 2.15
HF0404CF	1/4"	1/4" BSPP Straight	£0.74	€ 0.84
HF0604CF	1/4"	3/8" BSPP Straight	£1.24	€ 1.40
HF0406CF	3/8"	1/4" BSPP Straight	£1.50	€ 1.70
HF0606CF	3/8"	3/8" BSPP Straight	£1.15	€ 1.30
HF0806CF	3/8"	1/2" BSPP Straight	£1.48	€ 1.68
HF0608CF	1/2"	3/8" BSPP Straight	£1.78	€ 2.01
HF0808CF	1/2"	1/2" BSPP Straight	£1.48	€ 1.68
HF1008CF	1/2"	5/8" BSPP Straight	£3.00	€ 3.39
HF1208CF	1/2"	3/4" BSPP Straight	£3.40	€ 3.84
HF1010CF	5/8"	5/8" BSPP Straight	£3.00	€ 3.39
HF1210CF	5/8"	3/4" BSPP Straight	£3.78	€ 4.27
HF1212CF	3/4"	3/4" BSPP Straight	£2.60	€ 2.94
HF1612CF	3/4"	1" BSPP Straight	£3.60	€ 4.07
HF1616CF	1"	1" BSPP Straight	£3.60	€ 4.07
HF2016CF	1" 1	1.1/4" BSPP Straight	£9.00	€ 10.17
HF2020CF	1" 1/4	1" 1/4 BSPP Straight	£7.98	€ 9.02
HF2424CF	1" 1/2	1" 1/2 BSPP Straight	£10.28	€ 11.62
HF3232CF	2"	2" BSPP Straight	£23.32	€ 26.35



## BSP 45° SWIVEL FEMALE

www.flowfitonline.com  
TECH. DATA SHEET  
**VHS01**

REF.	HOSE DIAMETER	THREAD SIZE	NETT. PRICE	
			£ STERLING	€ EUROS
HF044504CF	1/4"	1/4" BSPP 45°	£0.94	€ 1.06
HF064504CF	1/4"	3/8" BSPP 45°	£1.61	€ 1.82
HF064506CF	3/8"	3/8" BSPP 45°	£1.34	€ 1.51
HF084506CF	3/8"	1/2" BSPP 45°	£1.34	€ 1.51
HF084508CF	1/2"	1/2" BSPP 45°	£2.08	€ 2.35
HF104508CF	1/2"	5/8" BSPP 45°	£3.60	€ 4.07
HF124508CF	1/2"	3/4" BSPP 45°	£5.82	€ 6.58
HF104510CF	5/8"	5/8" BSPP 45°	£4.70	€ 5.31
HF124510CF	5/8"	3/4" BSPP 45°	£5.00	€ 5.65
HF124512CF	3/4"	3/4" BSPP 45°	£3.30	€ 3.73
HF164516CF	1"	1" BSPP 45°	£5.88	€ 6.64
HF204520CF	1" 1/4	1" 1/4 BSPP 45°	£13.04	€ 14.74
HF244524CF	1" 1/2	1" 1/2 BSPP 45°	£26.00	€ 29.38
HF324532CF	2"	2" BSPP 45°	£58.02	€ 65.56



## BSP COMPACT 90° SWIVEL FEMALE

www.flowfitonline.com  
TECH. DATA SHEET  
**VHS01**

REF.	HOSE DIAMETER	THREAD SIZE	NETT. PRICE	
			£ STERLING	€ EUROS
HF0490C04CF	1/4"	1/4" BSPP 90°	£3.00	€ 3.43
HF0690C06CF	3/8"	3/8" BSPP 90°	£4.00	€ 4.57
HF0890C08CF	1/2"	1/2" BSPP 90°	£5.00	€ 5.72
HF1290C12CF	3/4"	3/4" BSPP 90°	£7.00	€ 8.00



## BSPW SWEPT 90° SWIVEL FEMALE

www.flowfitonline.com  
TECH. DATA SHEET  
**VHS01**

REF.	HOSE DIAMETER	THREAD SIZE	NETT. PRICE	
			£ STERLING	€ EUROS
HF049004CF	1/4"	1/4" BSPP 90°	£0.94	€ 1.06
HF069004CF	1/4"	3/8" BSPP 90°	£1.50	€ 1.70
HF069006CF	3/8"	3/8" BSPP 90°	£1.40	€ 1.58
HF089006CF	3/8"	1/2" BSPP 90°	£2.02	€ 2.28
HF069008CF	1/2"	3/8" BSPP 90°	£2.30	€ 2.60
HF089008CF	1/2"	1/2" BSPP 90°	£1.98	€ 2.24
HF109008CF	1/2"	5/8" BSPP 90°	£5.96	€ 6.73
HF129008CF	1/2"	3/4" BSPP 90°	£3.56	€ 4.02
HF109010CF	5/8"	5/8" BSPP 90°	£3.60	€ 4.07
HF129010CF	5/8"	3/4" BSPP 90°	£3.60	€ 4.07
HF129012CF	3/4"	3/4" BSPP 90°	£3.24	€ 3.66
HF169012CF	3/4"	1" BSPP 90°	£5.90	€ 6.67
HF169016CF	1"	1" BSPP 90°	£5.90	€ 6.67
HF209016CF	1"	1.1/4" BSPP 90°	£12.20	€ 13.79
HF209020CF	1" 1/4	1" 1/4 BSPP 90°	£13.04	€ 14.74
HF249024CF	1" 1/2	1" 1/2 BSPP 90°	£17.80	€ 20.11
HF329032CF	2"	2" BSPP 90°	£58.02	€ 65.56



## BSPW STUD MALE

www.flowfitonline.com  
TECH. DATA SHEET  
**VHS01**

REF.	HOSE DIAMETER	THREAD SIZE	NETT. PRICE	
			£ STERLING	€ EUROS
HM0204CF	1/4"	1/8" BSPP STUD	£1.94	€ 2.25
HM0404CF	1/4"	1/4" BSPP STUD	£1.06	€ 1.23
HM0406CF	1/4"	3/8" BSPP STUD	£0.79	€ 0.91
HM0804CF	1/4"	1/2" BSPP STUD	£2.67	€ 3.09
HM0405CF	5/16"	1/4" BSPP STUD	£1.74	€ 2.02
HM0605CF	5/16"	3/8" BSPP STUD	£1.37	€ 1.59
HM0406CF	3/8"	1/4" BSPP STUD	£2.44	€ 2.83
HM0606CF	3/8"	3/8" BSPP STUD	£1.16	€ 1.34
HM0806CF	3/8"	1/2" BSPP STUD	£1.71	€ 1.98
HM0608CF	1/2"	3/8" BSPP STUD	£1.84	€ 2.13
HM0808CF	1/2"	1/2" BSPP STUD	£1.62	€ 1.88
HM1008CF	1/2"	5/8" BSPP STUD	£3.27	€ 3.79
HM1208CF	1/2"	3/4" BSPP STUD	£5.52	€ 6.39
HM0810CF	5/8"	1/2" BSPP STUD	£4.23	€ 4.90
HM1010CF	5/8"	5/8" BSPP STUD	£3.75	€ 4.34
HM1210CF	5/8"	3/4" BSPP STUD	£3.87	€ 4.48
HM1212CF	3/4"	3/4" BSPP STUD	£3.15	€ 3.65
HM1612CF	3/4"	1" BSPP STUD	£8.20	€ 9.50
HM1616CF	1"	1" BSPP STUD	£6.20	€ 7.18
HM2016CF	1"	1" 1/4 BSPP STUD	£20.22	€ 23.42
HM2020CF	1" 1/4	1" 1/4 BSPP STUD	£11.80	€ 13.67
HM2420CF	1" 1/4	1" 1/2 BSPP STUD	£40.45	€ 46.85
HM2424CF	1" 1/2	1" 1/2 BSPP STUD	£25.17	€ 29.15
HM3224CF	1" 1/2	2" BSPP STUD	£54.21	€ 62.79
HM3232CF	2"	2" BSPP STUD	£48.27	€ 55.91

# JIC Fittings



## JIC STRAIGHT SWIVEL FEMALE

www.flowfitonline.com  
TECH. DATA SHEET  
**VHS01**

REF.	HOSE DIAMETER	THREAD SIZE	NETT. PRICE	
			£ STERLING	€ EUROS
HJ-JF0404CF	1/4"	7/16" JIC Straight	£0.76	€ 0.86
HJ-JF0504CF	1/4"	1/2" JIC Straight	£1.08	€ 1.22
HJ-JF0604CF	1/4"	9/16" JIC Straight	£0.84	€ 0.95
HJ-JF0606CF	3/8"	9/16" JIC Straight	£0.84	€ 0.95
HJ-JF0806CF	3/8"	3/4" JIC Straight	£1.12	€ 1.27
HJ-JF1006CF	3/8"	7/8" JIC Straight	£1.60	€ 1.81
HJ-JF0808CF	1/2"	3/4" JIC Straight	£1.12	€ 1.27
HJ-JF1008CF	1/2"	7/8" JIC Straight	£1.52	€ 1.72
HJ-JF1208CF	1/2"	1.1/16" JIC Straight	£2.24	€ 2.53
HJ-JF1010CF	5/8"	7/8" JIC Straight	£2.56	€ 2.89
HJ-JF1210CF	5/8"	1.1/16" JIC Straight	£3.58	€ 4.05
HJ-JF1212CF	3/4"	1.1/16" JIC Straight	£2.02	€ 2.28
HJ-JF1412CF	3/4"	1.3/16" JIC Straight	£6.00	€ 6.78
HJ-JF1612CF	3/4"	1.5/16" JIC Straight	£4.00	€ 4.52
HJ-JF1616CF	1"	1.5/16" JIC Straight	£4.44	€ 5.02
HJ-JF2016CF	1"	1.5/8" JIC Straight	£8.80	€ 9.94
HJ-JF2020CF	1" 1/4	1.5/8" JIC Straight	£5.28	€ 5.97
HJ-JF2420CF	1" 1/4	1" 7/8 JIC Straight	£18.54	€ 20.95
HJ-JF2424CF	1" 1/2	1" 7/8 JIC Straight	£6.92	€ 7.82
HJ-JF3232CF	2"	2" 1/2 JIC Straight	£21.88	€ 24.72



## JIC 45° SWIVEL FEMALE

www.flowfitonline.com  
TECH. DATA SHEET  
**VHS01**

REF.	HOSE DIAMETER	THREAD SIZE	NETT. PRICE	
			£ STERLING	€ EUROS
HJ-JF054504CF	1/4"	1/2" JIC 45°	£1.54	€ 1.74
HJ-JF064504CF	1/4"	9/16" JIC 45°	£1.54	€ 1.74
HJ-JF064506CF	3/8"	9/16" JIC 45°	£1.54	€ 1.74
HJ-JF084506CF	3/8"	3/4" JIC 45°	£2.12	€ 2.40
HJ-JF104506CF	3/8"	7/8" JIC 45°	£2.72	€ 3.07
HJ-JF084508CF	1/2"	3/4" JIC 45°	£2.12	€ 2.40
HJ-JF104508CF	1/2"	7/8" JIC 45°	£2.60	€ 2.94
HJ-JF14508CF	1/2"	1.1/16" JIC 45	£3.34	€ 3.77
HJ-JF104510CF	5/8"	7/8" JIC 45°	£3.34	€ 3.77
HJ-JF124510CF	5/8"	1.1/16" JIC 45	£5.98	€ 6.76
HJ-JF124512CF	3/4"	1.1/16" JIC 45°	£3.40	€ 3.84
HJ-JF164512CF	3/4"	1.5/16" JIC 45°	£10.00	€ 11.30
HJ-JF164516CF	1"	1.5/16" JIC 45°	£6.62	€ 7.48
HJ-JF204516CF	1"	1.5/8" JIC 45°	£28.64	€ 32.36
HJ-JF204520CF	1" 1/4	1.5/8" JIC 45°	£24.40	€ 27.57
HJ-JF244524CF	1" 1/2	1" 7/8 JIC 45°	£49.40	€ 55.82



## JIC SWEPT 90° SWIVEL FEMALE

www.flowfitonline.com  
TECH. DATA SHEET  
**VHS01**

REF.	HOSE DIAMETER	THREAD SIZE	NETT. PRICE	
			£ STERLING	€ EUROS
HJ-JF049004CF	1/4"	7/16" JIC 90°	£1.06	€ 1.20
HJ-JF059004CF	1/4"	1/2" JIC 90°	£1.46	€ 1.65
HJ-JF069004CF	1/4"	9/16" JIC 90°	£1.46	€ 1.65
HJ-JF044504CF	1/4"	7/16" JIC 90°	£1.32	€ 1.49
HJ-JF089006CF	3/8"	9/16" JIC 90°	£1.46	€ 1.65
HJ-JF089006CF	3/8"	3/4" JIC 90°	£1.46	€ 1.65
HJ-JF109006CF	3/8"	7/8" JIC 90°	£2.72	€ 3.07
HJ-JF089008CF	1/2"	3/4" JIC 90°	£2.02	€ 2.28
HJ-JF109008CF	1/2"	7/8" JIC 90°	£2.60	€ 2.94
HJ-JF129008CF	1/2"	1.1/16" JIC 90	£3.34	€ 3.77
HJ-JF109010CF	5/8"	7/8" JIC 90°	£2.90	€ 3.28
HJ-JF129010CF	5/8"	1.1/16 JIC 90°	£3.68	€ 4.16
HJ-JF129012CF	3/4"	1.1/16" JIC 90	£3.72	€ 4.20
HJ-JF149012CF	3/4"	1.3/16" JIC 90	£9.00	€ 10.17
HJ-JF169012CF	3/4"	1.5/16" JIC 90	£6.90	€ 7.80
HJ-JF209016CF	1"	1.5/8" JIC 90°	£6.30	€ 7.12
HJ-JF209020CF	1" 1/4	1.5/8" JIC 90°	£10.42	€ 11.77
HJ-JF249024CF	1" 1/2	1" 7/8 JIC 90°	£13.00	€ 14.69
HJ-JF329032CF	2"	2" 1/2 JIC 90°	£77.24	€ 87.28



## JIC STUD MALE

www.flowfitonline.com  
TECH. DATA SHEET  
**VHS01**

REF.	HOSE DIAMETER	THREAD SIZE	NETT. PRICE	
			£ STERLING	€ EUROS
JM0404CF	1/4"	7/16" JIC STUD	£1.21	€ 1.40
JM0504CF	1/4"	1/2" JIC STUD	£1.59	€ 1.84
JM0604CF	1/4"	9/16" JIC STUD	£1.53	€ 1.77
JM0605CF	5/16"	9/16" JIC STUD	£1.53	€ 1.77
JM0606CF	3/8"	9/16" JIC STUD	£1.06	€ 1.23
JM0806CF	3/8"	3/4" JIC STUD	£1.35	€ 1.56
JM0808CF	3/8"	7/8" JIC STUD	£3.15	€ 3.65
JM1006CF	1/2"	3/4" JIC STUD	£1.51	€ 1.75
JM1008CF	1/2"	7/8" JIC STUD	£2.03	€ 2.35
JM1208CF	1/2"	1" 1/16 JIC STUD	£3.72	€ 4.31
JM1010CF	5/8"	7/8" JIC STUD	£2.42	€ 2.80
JM1210CF	5/8"	1" 1/16 JIC STUD	£2.89	€ 3.35
JM1212CF	3/4"	1" 1/16 JIC STUD	£2.86	€ 3.31
JM1412CF	3/4"	1" 3/16 JIC STUD	£5.17	€ 5.99
JM1612CF	3/4"	1" 5/16 JIC STUD	£4.78	€ 5.54
JM1616CF	1"	1" 5/16 JIC STUD	£5.60	€ 6.49
JM2020CF	1" 1/4	1" 5/8 JIC STUD	£14.26	€ 16.52
JM2424CF	1" 1/2	1" 7/8 JIC STUD	£28.55	€ 33.07
JM3232CF	2"	2" 1/2 JIC STUD	£30.34	€ 35.14

# Metric Fittings



## METRIC STRAIGHT SWIVEL FEMALE

www.flowfitonline.com  
TECH. DATA SHEET  
**VHS01**

REF.	HOSE DIAMETER	THREAD SIZE	NETT. PRICE	
			£ STERLING	€ EUROS
MET-04-M12CF	1/4"	M12 x 1.5 METRIC STRAIGHT	£1.02	€ 1.15
MET-04-M12CF	1/4"	M14 x 1.5 METRIC STRAIGHT	£1.02	€ 1.15
MET-04-M16CF	1/4"	M16 x 1.5 METRIC STRAIGHT	£0.82	€ 0.93
MET-04-M18CF	1/4"	M18 x 1.5 METRIC STRAIGHT	£1.00	€ 1.13
MET-06-M16CF	3/8"	M16 x 1.5 METRIC STRAIGHT	£1.16	€ 1.31
MET-06-M18CF	3/8"	M18 x 1.5 METRIC STRAIGHT	£1.10	€ 1.24
MET-06-M22CF	3/8"	M22 x 1.5 METRIC STRAIGHT	£1.42	€ 1.60
MET-08-M22CF	1/2"	M22 x 1.5 METRIC STRAIGHT	£1.32	€ 1.49
MET-08-M26CF	1/2"	M26 x 1.5 METRIC STRAIGHT	£3.30	€ 3.73
MET-10-M26CF	5/8"	M26 x 1.5 METRIC STRAIGHT	£1.40	€ 1.58
MET-10-M30CF	5/8"	M30 x 1.5 METRIC STRAIGHT	£2.50	€ 2.83
MET-12-M30CF	3/4"	M30 x 2 METRIC STRAIGHT	£2.32	€ 2.62
MET-16-M36CF	1"	M36 x 2 METRIC STRAIGHT	£5.20	€ 5.88



## METRIC 45° SWIVEL FEMALE

www.flowfitonline.com  
TECH. DATA SHEET  
**VHS01**

REF.	HOSE DIAMETER	THREAD SIZE	NETT. PRICE	
			£ STERLING	€ EUROS
MET-0445-M12CF	1/4"	M12 x 1.5 METRIC 45°	£1.24	€ 1.40
MET-0445-M14CF	1/4"	M14 x 1.5 METRIC 45°	£1.42	€ 1.60
MET-0445-M16CF	1/4"	M16 x 1.5 METRIC 45°	£1.42	€ 1.60
MET-0645-M16CF	3/8"	M16 x 1.5 METRIC 45°	£1.66	€ 1.88
MET-0645-M18CF	3/8"	M18 x 1.5 METRIC 45°	£1.70	€ 1.92
MET-0845-M22CF	1/2"	M22 x 1.5 METRIC 45°	£2.18	€ 2.46
MET-1045-M26CF	5/8"	M26 x 1.5 METRIC 45°	£2.72	€ 3.07
MET-1245-M30CF	3/4"	M30 x 2 METRIC 45°	£4.30	€ 4.86
MET-1645-M36CF	1"	M36 x 2 METRIC 45°	£8.70	€ 9.83
MET-2045-M45CF	1" 1/4	M45 X 2 METRIC 45°	£14.18	€ 16.02
MET-2445-M52CF	1" 1/2	M52 X 2 METRIC 45°	£21.50	€ 24.30



## METRIC SWEPT 90° SWIVEL FEMALE

www.flowfitonline.com  
TECH. DATA SHEET  
**VHS01**

REF.	HOSE DIAMETER	THREAD SIZE	NETT. PRICE	
			£ STERLING	€ EUROS
MET-0490-M12CF	1/4"	M12 x 1.5 METRIC 90°	£1.16	€ 1.31
MET-0490-M14CF	1/4"	M14 x 1.5 METRIC 90°	£1.36	€ 1.54
MET-0490-M16CF	1/4"	M16 x 1.5 METRIC 90°	£1.36	€ 1.54
MET-0490-M18CF	1/4"	M18 x 1.5 METRIC 90°	£1.40	€ 1.58
MET-0690-M16CF	3/8"	M16 x 1.5 METRIC 90°	£1.64	€ 1.85
MET-0690-M18CF	3/8"	M18 x 1.5 METRIC 90°	£1.64	€ 1.85
MET-0890-M22CF	1/2"	M22 x 1.5 METRIC 90°	£2.08	€ 2.35
MET-1090-M26CF	5/8"	M26 x 1.5 METRIC 90°	£2.62	€ 2.96
MET-1290-M26CF	3/4"	M26 x 1.5 METRIC 90°	£7.02	€ 7.93
MET-1290-M30CF	3/4"	M30 x 2 METRIC 90°	£4.14	€ 4.68
MET-1690-M36CF	1"	M36 x 2 METRIC 90°	£7.94	€ 8.97
MET-2090-M45CF	1" 1/4	M45 X 2 METRIC 90°	£13.62	€ 15.39
MET-2490-M52CF	1" 1/2	M52 X 2 METRIC 90°	£20.66	€ 23.35



## METRIC STUD MALE

www.flowfitonline.com  
TECH. DATA SHEET  
**VHS01**

REF.	HOSE DIAMETER	THREAD SIZE	NETT. PRICE	
			£ STERLING	€ EUROS
METM-04-M14CF	1/4"	M14 x 1.5 METRIC STUD	£1.01	€ 1.17
METM-04-M16CF	1/4"	M16 x 1.5 METRIC STUD	£1.63	€ 1.89
METM-05-M16CF	5/16"	M16 x 1.5 METRIC STUD	£1.34	€ 1.55
METM-05-M18CF	5/16"	M18 x 1.5 METRIC STUD	£2.00	€ 2.32
METM-06-M16CF	3/8"	M16 x 1.5 METRIC STUD	£1.48	€ 1.71
METM-06-M18CF	3/8"	M18 x 1.5 METRIC STUD	£1.19	€ 1.38
METM-06-M22CF	3/8"	M22 x 1.5 METRIC STUD	£2.44	€ 2.83
METM-08-M22CF	1/2"	M22 x 1.5 METRIC STUD	£1.76	€ 2.04
METM-08-M26CF	1/2"	M26 x 1.5 METRIC STUD	£3.58	€ 4.15
METM-10-M26CF	5/8"	M26 x 1.5 METRIC STUD	£3.63	€ 4.20
METM-12-M30CF	3/4"	M30 x 2 METRIC STUD	£3.98	€ 4.61
METM-16-M36CF	1"	M36 x 2 METRIC STUD	£6.58	€ 7.62
METM-20-M45CF	1" 1/4	M45 x 2 METRIC STUD	£11.20	€ 12.97
METM-24-M52CF	1" 1/2	M52 x 2 METRIC STUD	£16.65	€ 19.28

## Hose Protection

### PLASTIC SPIRAL HOSE SLEEVE

www.flowfitonline.com  
TECH. DATA SHEET  
**VHS01**

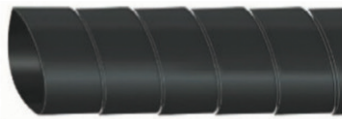

Provides high strength abrasion resistance for most types of hydraulic, pneumatic and industrial hose assemblies across a wide range of industries including: mining, forestry, drill rigs, plant and agricultural machinery, automotive, marine and offshore.

Exceptional anti-crushing performance, High abrasion resistance and good UV resistance.

Easy installation and routing, proven in arduous conditions.

Conveniently coiled and packed in cartons for easy storage.

Suitable for wrapping single hoses or multiple hose looms.

Working Temperature -40°C to +90°C

PART NO.	2SN	2SC	INSIDE	OUTSIDE	THICKNESS	SPIRAL PITCH	BOX	PER METRE NETT. PRICE	
			MM	MM	MM	MM		£ STERLING	€ EUROS
PLASTICSPIRAL013	1/4"	1/4"	13	16	1.6	12	20	£1.25	€ 1.44
PLASTICSPIRAL017	3/8"	3/8"	17	20	1.9	16	20	£1.50	€ 1.73
PLASTICSPIRAL021	1/2"	1/2"	21	25	2.9	20	20	£1.75	€ 2.02
PLASTICSPIRAL027	5/8", 3/4"	5/8", 3/4"	27	32	2.3	22	20	£2.75	€ 3.17
PLASTICSPIRAL035	1"	1"	35	40	2.7	24	20	£3.00	€ 3.50
PLASTIC SPIRAL045	1 1/4", 1 1/2"	---	45	50	3	30	20	£3.50	€ 4.03
PLASTIC SPIRAL069	2"	---	69	75	3.8	42	20	£7.25	€ 8.36

# Hand Hose Crimpers

## FFH16

### Portable Hand Hose Crimping Machine – Max hose size 1” (DN25, -16)

Light portable hand crimper for on-site hose repairs.

The FFH16 crimper is the ideal tool for ON-SITE hydraulic hose repair jobs.

Typically used in agriculture, forestry, road works either loaded at the back of the mobile van or in a workshop as the emergency hose repair tool.

The machine is equipped with a resistant and robust pump, and a simple adjustment vernier.

The double speed hand pump limits the number of pump strokes needed to achieve a crimp.

The end of the crimp is indicated thanks to a colored rod coming out of the vernier when the desired crimp OD is reached.

The head of the machine is also internally protected against debris or dust that could damage the inside of the cylinder and the seals.

Crimps up to 1" Hose



#### PRODUCT FEATURES

- LIGHT WEIGHT 28 KGS
- ROBUST TECHNOLOGY
- COMPACT AND BALANCED WEIGHT
- EASY TO USE

#### TECHNICAL SPECIFICATION

Capacity : For hydraulic hose crimping and intermittent use	2-SN: 1" (DN25; -16) 4-SP: 1/2" (DN13; -10) Limit for assembly with 2 x 90° elbows: max 1/2" (DN13)
Hand Pump	Double Speed Pump with handle, delivered with oil HV32 Max. 350 bar
Radial Crimp force	80 tons
Die opening	Ø Die. + 20mm
Opening without dies	59 mm
Length of master die shoe	56 mm
Dimensions of machine	Width: 300mm Depth: 220mm Height: 400mm
Net weight (with oil, without dies)	28 kgs
Packing details (for transport purposes)	Each Machine is packed in a wood crate suitable for long haul freight, conform to NIMP15 norms Dimension of packing : 26x41x48cms, Gross weight (with 6 sets of dies) : 35 kgs

#### PRICE FOR MACHINE

**£1,233.37 +VAT**

1" DIE PART OF CRIMPER

SELECT ADDITIONAL DIES FROM TABLE BELOW

PART NO.	DIE SIZE Ø	HOSE SIZE	NETT. PRICE	
			£ STERLING	€ EUROS
FF60DIES-10	10	*BY MAN	£141.62	€ 164.00
FF61DIES-12	12	*BY MAN	£141.62	€ 164.00
FF62DIES-15	15	*BY MAN	£141.62	€ 164.00
FF63DIES-18	18	**1/4"	£141.62	€ 164.00
FF64DIES-21	21	**3/8"	£141.62	€ 164.00
FF65DIES-24	24	**1/2"	£141.62	€ 164.00
FF66DIES-27	27	**5/8"	£141.62	€ 164.00
FF67DIES-30	30	**3/4"	£141.62	€ 164.00
FF67DIES-30	30	3/4"	£141.62	€ 164.00

\*\*The hose sizes stating hose size in table above are for use with Flowfits Vincke Hydraulic Hose!

\*BY MAN = By Manufacturer, Hose size determined by hose manufacturers crimping data- Please check with YOUR hose supplier!

## FFS16/80T

### Portable Hose Crimping Machine Max 1" 2-SN (DN25, -16)

The FFS16/80T is ideal for on-site hose repairs as it will help to repair hoses with uneasy access. The magnetic head of the FFS16/80T also allows you to position the head at an ideal height or safely position the head onto the boom of a machine where a hose needs to be repaired.

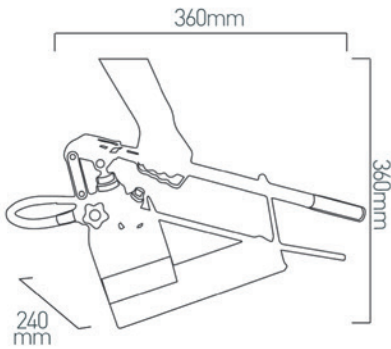

Crimps up to 1" Hose

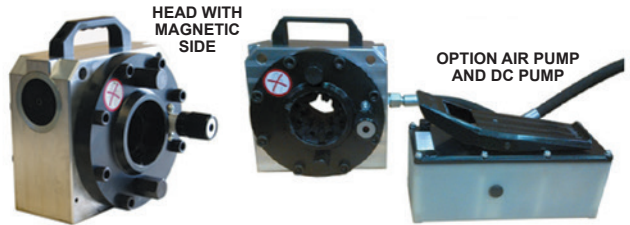

#### PRODUCT FEATURES

- SPLITTED HEAD AND PUMP CONCEPT
- HEAD WITH MAGNET
- IDEAL FOR ON SITE HOSE REPAIRS

#### TECHNICAL SPECIFICATION

Capacity : For hydraulic hose crimping and intermittent use	2-SN: 1" (DN25; -16) 4-SP: 1/2" (DN13; -10) Limit for assembly with 2 x 90° elbows: max 1/2" (DN13)
Hand Pump	Double Stage 25cm3 + 5cm3, Max 320 Bar
Radial Crimp force	80 tons
Die opening	Ø Die. + 20mm
Opening without dies	56 mm
Head Dimensions	Width: 240mm Depth: 130mm Height: 240mm
Pump Dimensions	Width: 360mm Depth: 130mm Height: 360mm
Net weight (with oil, without dies)	20 Kg for one magnetic head (NKS16.1) 9 Kg for hand pump support with drawer (NKS16-HP1)
Packing details (for transport purposes)	Wooden crate conform to ISPM15 Crate size: 26x41x48cms Gross weight (with 6 sets of dies): 35 Kgs

#### PRICE FOR MACHINE

**£1,662.24 +VAT**

1" DIE PART OF CRIMPER

SELECT DIES FROM TABLE BELOW

PART NO.	DIE SIZE Ø	HOSE SIZE	NETT. PRICE	
			£ STERLING	€ EUROS
FF60DIES-10	10	*BY MAN	£141.62	€ 164.00
FF61DIES-12	12	*BY MAN	£141.62	€ 164.00
FF62DIES-15	15	*BY MAN	£141.62	€ 164.00
FF63DIES-18	18	**1/4"	£141.62	€ 164.00
FF64DIES-21	21	**3/8"	£141.62	€ 164.00
FF65DIES-24	24	**1/2"	£141.62	€ 164.00
FF66DIES-27	27	**5/8"	£141.62	€ 164.00
FF67DIES-30	30	**3/4"	£141.62	€ 164.00
FF67DIES-30	30	3/4"	£141.62	€ 164.00

\*\*The hose sizes stating hose size in table above are for use with Flowfits Vincke Hydraulic Hose!

\*BY MAN = By Manufacturer, Hose size determined by hose manufacturers crimping data- Please check with YOUR hose supplier!



**FFH25**

**Hose Crimper Operated with Double Stage Hand Pump, Max Hose Size 1 1/2" 2-SN (DN38, -24)**

Compact, Precise, Simple and Easy to use hose crimping machine with Aluminium head

Reliable and precise hand hose crimping machine with perfect geometry results. This machine is compact, reliable, robust and easy to use and handle thanks to its low weight aluminium head (40KG's).

The use of this machine is ideally recommended for service hose assembly up to 1" 4-Wire spiral and 1 1/2" 2-Wire and can also be used to crimp small tubes and cables.

Picture : FFH25 with Double Speed Pump

**Crimps up to 1 1/2" Hose**



High Precision Vernier Sound Signal box with Battery Tester



**PRODUCT FEATURES**

- **COMPACT MACHINE**
- **EASY TO USE - 40 KGS**
- **DOUBLE SPEED HAND PUMP**
- **HIGH PRECISION VERNIER WITH SOUND SIGNAL**

**TECHNICAL SPECIFICATION**

Maximum capacity : For an intermittent use in high pressure hose assembling	2-SN: 1 1/2" (DN38, -24) 4-SP: 1 1/4" (DN32, -20) 6-SP or Interlock: 1" (DN25, -16)
Hand Pump	Max. 340 bar Double stage pump with 1st stage = Fast approach (25 cm3/ stroke, max. 50b) + 2nd Stage = Crimp approach (5 cm3/stroke, max. 320b)
Radial Crimp force	135 Tons (340 bar)
Die opening	Ø Die + 18mm
Opening without dies	90mm
Dimensions of machine	Width: 500mm Depth: 300mm Height: 550mm
Net weight (with oil, without dies)	40 kgs (with oil, w/o dies)
Packing details (for transport purposes)	Each machine on wood crate (NIMP15 conform) Packing dimensions : 55x70x75cms, 55 kgs

**PRICE FOR MACHINE**

**£2,259.95 +VAT**

NO DIE INCLUDED

SELECT DIES FROM TABLE BELOW

PART NO.	DIE SIZE Ø	HOSE SIZE	NETT. PRICE	
			£ STERLING	€ EUROS
FF25-DIE-06	6	*BY MAN	£231.05	€ 267.56
FF25-DIE-08	8	*BY MAN	£231.05	€ 267.56
FF25-DIE-10	10	*BY MAN	£176.09	€ 203.91
FF25-DIE-12	12	*BY MAN	£176.09	€ 203.91
FF25-DIE-15	15	*BY MAN	£176.09	€ 203.91
FF25-DIE-18	18	**1/4"	£176.09	€ 203.91
FF25-DIE-21	21	**3/8"	£176.09	€ 203.91
FF25-DIE-24	24	**1/2"	£176.09	€ 203.91
FF25-DIE-27	27	**5/8"	£176.09	€ 203.91
FF25-DIE-30	30	**3/4"	£176.09	€ 203.91
FF25-DIE-33	33	*BY MAN	£176.09	€ 203.91
FF25-DIE-39	39	**1"	£176.09	€ 203.91
FF25-DIE-48	48	*BY MAN	£176.09	€ 203.91
FF25-DIE-51	51	**1 1/4"	£176.09	€ 203.91
FF25-DIE-57	57	1 1/2"	£231.05	€ 267.56

\*\*The hose sizes stating hose size in table above are for use with Flowfits Vincke Hydraulic Hose!

\*BY MAN = By Manufacturer, Hose size determined by hose manufacturers crimping data- Please check with YOUR hose supplier!

# Workshop Hose Crimpers

## FF25

**Compact, Precise, Simple and easy to use hose crimping machine.**

Simple and economy hose crimping machine with high precision and perfect geometry results. This machine is compact, reliable, robust and easy to use and handle thanks to its low weight (65 kgs).

The use of this machine is ideally recommended for service hose assembly up to 1" 4-Wire spiral and 1 1/2" 2-Wire and can also be used to crimp small tubes and cables.

We recommend the use of this machine for an intermittent use of approximately 30 to 50 hose assemblies per day

**Crimps up to 1 1/2" Hose**



Optional

### PRODUCT FEATURES

- **COMPACT & LIGHT, EASY TO HANDLE**
- **SIMPLE TO USE**
- **FRONT RACKINGS FOR DIE**
- **HIGH PRECISION**

### TECHNICAL SPECIFICATION

Maximum Capacity For an intermittent use in high pressure hose assembling	2-SN: 1 1/2" (DN32; -20) 4-SP: 1" (DN25, -20) 6-SP ou Interlock: 3/4" (DN19, -12)
Motor	2.2 kW 400V 3-PH 50Hz (NK25E.1) 2.2 kW 230V 3-PH 50Hz (NK25E.2) Other electric voltages available : 230V 3-PH 60Hz, 230V 1-PH 60Hz, 110V 1-PH 60Hz
Radial Press Force	120 Tons
Opening with Dies	Ø Die + 18mm
Opening without Dies	59 mm
Length of master die shoe	65mm
Net Weight	62 KGs (with oil, w/o dies)
Transport Packing Details	Each machine on wood crate (NIMP15 conform) Packing dimensions : 58x70x75cms, 85 KGs

### PRICE FOR MACHINE

**£2,913.49 +VAT**

NO DIE INCLUDED

SELECT DIES FROM TABLE BELOW

PART NO.	DIE SIZE Ø	HOSE SIZE	NETT. PRICE	
			£ STERLING	€ EUROS
FF25-DIE-06*	6	*BY MAN	£231.05	€ 267.56
FF25-DIE-08*	8	*BY MAN	£231.05	€ 267.56
FF25-DIE-10	10	*BY MAN	£176.09	€ 203.91
FF25-DIE-12	12	*BY MAN	£176.09	€ 203.91
FF25-DIE-15	15	*BY MAN	£176.09	€ 203.91
FF25-DIE-18	18	**1/4"	£176.09	€ 203.91
FF25-DIE-21	21	**3/8"	£176.09	€ 203.91
FF25-DIE-24	24	**1/2"	£176.09	€ 203.91
FF25-DIE-27	27	**5/8"	£176.09	€ 203.91
FF25-DIE-30	30	**3/4"	£176.09	€ 203.91
FF25-DIE-33	33	*BY MAN	£176.09	€ 203.91
FF25-DIE-39	39	**1"	£176.09	€ 203.91
FF25-DIE-45	45	*BY MAN	£176.09	€ 203.91
FF25-DIE-48*	48	*BY MAN	£176.09	€ 203.91
FF25-DIE-51*	51	**1 1/4"	£176.09	€ 203.91
FF25-DIE-57*	57	**1 1/2"	£231.05	€ 267.56

\*Available upon request

\*\*The hose sizes stating hose size in table above are for use with Flowfits Vincke Hydraulic Hose!

\*BY MAN = By Manufacturer, Hose size determined by hose manufacturers crimping data- Please check with YOUR hose supplier!

**FF-30**

**Electric Hose Crimping Machine  
Max 1 1/2" 2-SN (DN38, -24)**

Enlarged opening for elbows, Minimum space requirement.

Head protected by foam inserts.

This machine is compact, reliable, robust and easy to use and handle thanks to its low weight (65 kgs).

Included : 2 x Side Protection Panels

Optional : Front Die Holders (PDR)  
Quick Change Tool (QCT), Support Bench (ST)

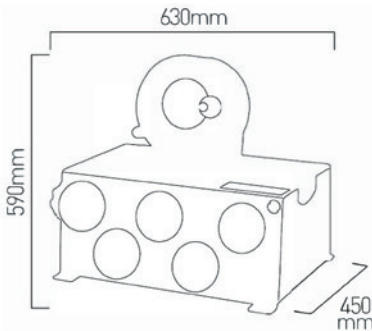

Optional



**PRODUCT FEATURES**

- COMPACT, EASY TO USE
- ECONOMICAL HOSE CRIMPER
- FRONT RACKINGS FOR DIE
- HIGH PRECISION

**TECHNICAL SPECIFICATION**

Indicative Hose Capacity	2-SN: 1 1/2" [DN38; -24] 4-SP: 1 1/4 [DN32, -20] R13/R15/Interlock: 1" [DN25; -16] Max. size for assembly with 2 x 90° elbows: max. 3/4" [ON 19]
Motor/Electrics	2.2 kW -400V3-PH + Earth+ Neutral 50Hz 2.2 kW - 230V 1-PH 60Hz 1.5 kW - 11 0V 1-PH 60Hz 2 kW-12 VDC [NK30-DC12]
Radial Press Force	130 Tons
Opening	Ø Die + 28mm [Press Path + 12mm]
Opening without dies	98mm
Master Die Shoe Length	75mm
Nett Weight	68 KG
Packing	Wooden crate conform to ISPM15 Crate size : 58x70x75cms Gross weight [with 5 sets of dies]: 105 kgs
Noise Level	< 70 dB[A]

**PRICE FOR MACHINE**

**£3,172.40 +VAT**

NO DIE INCLUDED

SELECT DIES FROM TABLE BELOW

PART NO.	DIE SIZE Ø	HOSE SIZE	NETT. PRICE	
			£ STERLING	€ EUROS
FF25-DIE-06	6	*BY MAN	£231.05	€ 267.56
FF25-DIE-08	8	*BY MAN	£231.05	€ 267.56
FF25-DIE-10	10	*BY MAN	£176.09	€ 203.91
FF25-DIE-12	12	*BY MAN	£176.09	€ 203.91
FF25-DIE-15	15	*BY MAN	£176.09	€ 203.91
FF25-DIE-18	18	**1/4"	£176.09	€ 203.91
FF25-DIE-21	21	**3/8"	£176.09	€ 203.91
FF25-DIE-24	24	**1/2"	£176.09	€ 203.91
FF25-DIE-27	27	**5/8"	£176.09	€ 203.91
FF25-DIE-30	30	**3/4"	£176.09	€ 203.91
FF25-DIE-33	33	*BY MAN	£176.09	€ 203.91
FF25-DIE-39	39	**1"	£176.09	€ 203.91
FF25-DIE-48	48	*BY MAN	£176.09	€ 203.91
FF25-DIE-51	51	**1 1/4"	£176.09	€ 203.91
FF25-DIE-57	57	**1 1/2"	£231.05	€ 267.56

\*\*The hose sizes stating hose size in table above are for use with Flowfits Vincke Hydraulic Hose!  
\*BY MAN = By Manufacturer, Hose size determined by hose manufacturers crimping data- Please check with YOUR hose supplier!

## FF30-PRO

### Service Workshop Hose Crimper, Max 1 1/2" 2-SN (DN38, -24)

Multipurpose and Universal Workshop crimper

The use of this machine is ideally recommended for service hose assembly up to 1 1/2" 2-Wire spiral.

The capacity of this machine covers the most widely used hoses on the market and thanks to its large opening you can pass 2 x 90 deg. elbows with BSP nut up to 1 1/4".

We recommend the use of this machine for an intermittent use of approximately 50 to 100 hose assemblies per day

**Crimps up to 1 1/2" Hose**



Option : QCT-NLS

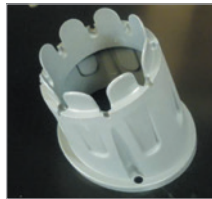

Option : PDR-1



Option : WP-12PDR

### TECHNICAL SPECIFICATION

Maximum capacity : For an intermittent use in high pressure hose assembling	2-SN: 1 1/2" (DN32; -20) 4-SP: 1 1/4" (DN32, -20) 6-SP or Interlock: 1" (DN25, -16)
Motor	3KW 400V 50HZ 3-PH 2.2KW 230V 50HZ 1-PH
Radial Press Force	135 Tons
Opening with Dies	Ø Die + 28mm (Press path : +12mm)
Opening without Dies	98mm
Length of Master Die Shoes	75mm
Dimensions of the Machine	Width : 800mm x Depth : 440mm x Height : 670mm
Options Available	<ul style="list-style-type: none"> <li>• Quick Change Tool (QCT-NLS)</li> <li>• Individual Die Storage Rack (PDR-1)</li> <li>• Die Storage Panel (WP-12PDR)</li> <li>• Foot Switch (FS)</li> </ul>
Net Weight	70 kgs (with oil, w/o dies)
Transport Packing Details	Each machine on wood crate (NIMP15 conform) Packing dimensions : 58x70x75cms, 105 kgs (with 8 sets of dies)

### PRICE FOR MACHINE

**£3,955.88 + VAT**

NO DIE INCLUDED

SELECT DIES FROM TABLE BELOW

PART NO.	DIE SIZE Ø	HOSE SIZE	NETT. PRICE	
			£ STERLING	€ EUROS
FF25-DIE-06	6	*BY MAN	£231.05	€ 267.56
FF25-DIE-08	8	*BY MAN	£231.05	€ 267.56
FF25-DIE-10	10	*BY MAN	£176.09	€ 203.91
FF25-DIE-12	12	*BY MAN	£176.09	€ 203.91
FF25-DIE-15	15	*BY MAN	£176.09	€ 203.91
FF25-DIE-18	18	**1/4"	£176.09	€ 203.91
FF25-DIE-21	21	**3/8"	£176.09	€ 203.91
FF25-DIE-24	24	**1/2"	£176.09	€ 203.91
FF25-DIE-27	27	**5/8"	£176.09	€ 203.91
FF25-DIE-30	30	**3/4"	£176.09	€ 203.91
FF25-DIE-33	33	*BY MAN	£176.09	€ 203.91
FF25-DIE-39	39	**1"	£176.09	€ 203.91
FF25-DIE-45	45	*BY MAN	£176.09	€ 203.91
FF25-DIE-48	48	*BY MAN	£176.09	€ 203.91
FF25-DIE-51	51	**1 1/4"	£176.09	€ 203.91
FF25-DIE-57	57	**1 1/2"	£231.05	€ 267.56

\*\*The hose sizes stating hose size in table above are for use with Flowfits Vincke Hydraulic Hose!

\*BY MAN = By Manufacturer, Hose size determined by hose manufacturers crimping data- Please check with YOUR hose supplier!

## FF40-PRO

### Electric hose crimping machine for hoses up to 2" (DN50)

Compact, Precise, Simple and easy to use hose crimping machine.

Simple and economy hose crimping machine with high precision, large opening and perfect geometry results. Crimp force 240 tons, Universal hose crimper. Radial movement of dies, Head protected by foam inserts. Professional ergonomony

**Crimps up to 2" Hose**



#### PRODUCT FEATURES

- INTERLOCK ASSEMBLIES UP TO 1 1/4" (DN32)
- ERGONOMIC WORKING SPACE
- IDEAL FOR LONG DROP ELBOWS
- EASY GREASING SYSTEM

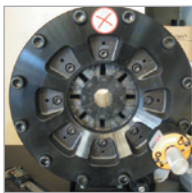

Large die opening = no need to remove dies  
Radial die travel = easy positioning of fitting



Front flange cuts allow long drop elbows

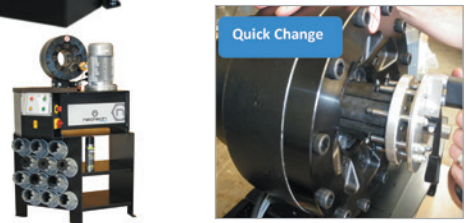

Quick Change

#### PRICE FOR MACHINE

**£5,943.44 +VAT**

NO DIE INCLUDED

#### SELECT DIES FROM TABLE BELOW

PART NO.	DIE SIZE Ø	HOSE SIZE	NETT. PRICE	
			£ STERLING	€ EUROS
FF40-DIE-06	6	*BY MAN	£231.05	€ 267.56
FF40-DIE-08	8	*BY MAN	£231.05	€ 267.56
FF40-DIE-10	10	*BY MAN	£176.09	€ 203.91
FF40-DIE-12	12	*BY MAN	£176.09	€ 203.91
FF40-DIE-15	15	*BY MAN	£176.09	€ 203.91
FF40-DIE-18	18	**1/4"	£176.09	€ 203.91
FF40-DIE-21	21	**3/8"	£176.09	€ 203.91
FF40-DIE-24	24	**1/2"	£176.09	€ 203.91
FF40-DIE-27	27	**5/8"	£176.09	€ 203.91
FF40-DIE-30	30	**3/4"	£176.09	€ 203.91
FF40-DIE-33	33	*BY MAN	£176.09	€ 203.91
FF40-DIE-36	36	*BY MAN	£231.05	€ 267.56
FF40-DIE-39	39	**1"	£176.09	€ 203.91
FF40-DIE-42	42	*BY MAN	£231.05	€ 267.56
FF40-DIE-45	45	*BY MAN	£176.09	€ 203.91
FF40-DIE-48	48	*BY MAN	£176.09	€ 203.91
FF40-DIE-51	51	**1 1/4"	£176.09	€ 203.91
FF40-DIE-54	54	*BY MAN	£231.05	€ 267.56
FF40-DIE-57	57	**1 1/2"	£176.09	€ 203.91
FF40-DIE-62	62	*BY MAN	£231.05	€ 267.56
FF40-DIE-66	66	**2"	£176.09	€ 203.91
FF40-DIE-70	70	*BY MAN	£310.00	€ 358.98

#### TECHNICAL SPECIFICATION

Maximum capacity : For an intermittent use in high pressure hose assembling	2-SN: 2" (DN50; -32) 4-SP/R12: 2" (DN50, -32) R13/R15/4-SH/Interlock: 1 1/4" (DN32, -20) Limit with 2 x 90 Elbows: Max. 1 1/4" (DN32) Max. Crimp Diameter: 77mm (with Sp. Dies N° 70)
Motor	4 KW 400V 50 HZ 3-PH
Radial Press Force	240 Tons
Opening with Dies	Ø Die + 38mm
Opening without Dies	118mm
Length of Master Die Shoes	100mm
Dimensions of the Machine	Width : 800mm x Depth : 440mm x Height : 800mm
Net Weight	185 kgs (with oil, w/o dies)
Transport Packing Details	Wood Crate conform to NIMP15 conform regulation Packing dimensions : 110x78x110cms Gross Weight 235 kgs (with 10 sets of dies)
Noise Level	< 70 dB(A)

\*\*The hose sizes stating hose size in table above are for use with Flowfits Vincke Hydraulic Hose!

\*BY MAN = By Manufacturer, Hose size determined by hose manufacturers crimping data- Please check with YOUR hose supplier!

## FF40/200T

### Electric Hose Crimping Machine, Max 2" (DN50-32)

Compact, Precise, Simple and easy to use hose crimping machine.

Simple and economy hose crimping machine with high precision, large opening and perfect geometry results.

Crimp force 200 tons, Universal hose crimper. Radial movement of dies, Head protected by foam inserts. Professional ergonomomy

**Crimps up to 2" Hose**



#### PRODUCT FEATURES

- INTERLOCK AND R15 ASSEMBLIES UP TO 1 1/4" (DN32)
- ERGONOMIC WORKING SPACE
- IDEAL FOR LONG DROP ELBOWS
- EASY GREASING SYSTEM

#### TECHNICAL SPECIFICATION

Indicative Hose Capacity	2-SN: 2" [DN50; -32] 4-SP: 1 1/2" .. [DN38, -24] R13/R15/Interlock: 1 1/4" [DN32; -20] Max. size for assembly with 2 x 90° elbows: max. 3/4" [DN 19]
Motor/Electrics	3 KW -230/400V 3-PH 3 KW - 230V 1-PH (20A) 2 KW (12V DC) FF30-DC 2 kW-12 VDC [NK30-DC12]
Radial Press Force	270 Tons
Opening	Ø Die + 38mm [Press Path + 14mm]
Opening without Dies	118mm
Master Die Shoe Length	100mm
Dimensions	Width : 800mm Depth : 440mm Height : 700mm
Net Weight (with full oil tank, w/o dies)	180 KG
Packing	Wooden crate conform to ISPM15 Crate size : 110x78x110cms Gross weight [with 5 sets of dies]: 230 kgs
Noise Level	< 70 dB[A] with standard hydraulic mounting

#### PRICE FOR MACHINE

**£5,635.43 +VAT**

NO DIE INCLUDED

SELECT DIES FROM TABLE BELOW

PART NO.	DIE SIZE Ø	HOSE SIZE	NETT. PRICE	
			£ STERLING	€ EUROS
FF40-DIE-06	6	*BY MAN	£231.05	€ 267.56
FF40-DIE-08	8	*BY MAN	£231.05	€ 267.56
FF40-DIE-10	10	*BY MAN	£176.09	€ 203.91
FF40-DIE-12	12	*BY MAN	£176.09	€ 203.91
FF40-DIE-15	15	*BY MAN	£176.09	€ 203.91
FF40-DIE-18	18	**1/4"	£176.09	€ 203.91
FF40-DIE-21	21	**3/8"	£176.09	€ 203.91
FF40-DIE-24	24	**1/2"	£176.09	€ 203.91
FF40-DIE-27	27	**5/8"	£176.09	€ 203.91
FF40-DIE-30	30	**3/4"	£176.09	€ 203.91
FF40-DIE-33	33	*BY MAN	£176.09	€ 203.91
FF40-DIE-36	36	*BY MAN	£231.05	€ 267.56
FF40-DIE-39	39	**1"	£176.09	€ 203.91
FF40-DIE-42	42	*BY MAN	£231.05	€ 267.56
FF40-DIE-45	45	*BY MAN	£176.09	€ 203.91
FF40-DIE-48	48	*BY MAN	£176.09	€ 203.91
FF40-DIE-51	51	**1 1/4"	£176.09	€ 203.91
FF40-DIE-54	54	*BY MAN	£231.05	€ 267.56
FF40-DIE-57	57	**1 1/2"	£176.09	€ 203.91
FF40-DIE-62	62	*BY MAN	£231.05	€ 267.56
FF40-DIE-66	66	**2"	£176.09	€ 203.91
FF40-DIE-70	70	*BY MAN	£310.00	€ 358.98

\*\*The hose sizes stating hose size in table above are for use with Flowfits Vincke Hydraulic Hose!

\*BY MAN = By Manufacturer, Hose size determined by hose manufacturers crimping data- Please check with YOUR hose supplier!

**FF60**

**Electric Hose Crimping Machine for hoses up to 2" 4-SH & 4" Industrial**

The FF60 is a versatile hose crimping machine with a robust head design, combining a high crimp force and a large opening in order to press multi-spiral hoses up to 2" and industrial hoses up to 4". The radial movement of the dies makes it a comfortable machine to use for a professional hose workshop.

**Crimps up to 2" Hose or 4" Industrial Hose**



**PRODUCT FEATURES**

- **INDUSTRIAL AND 2-SN HOSES UP TO 4" WITH CAM & GROOVE**
- **ERGONOMIC WORKING SPACE**
- **HEAD PROTECTED THANKS TO PROTECTION BETWEEN DIES**
- **EASY GREASING SYSTEM**

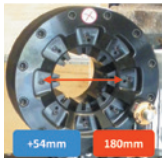

Large die opening = 180mm  
Radial die travel = + 54mm



Easy positioning of fitting thanks to radial die movement



Front flange cuts allow long drop elbows

**TECHNICAL SPECIFICATION**

Max. Capacities : For intermittent use of high pressure hose assembling	2-SN et LP Industrial: 4" (DN100, -64) 2-SN and Industrial: 4" (DN100, -64) 4-SH/R13: Max. 2" (DN50, -32) R15: Max. 1 1/2" (DN38, -24) Limit with 2 x 90 elbows: max: 3' (DN6 3) Max crimp diameter: ... 145mm ( with Dies N° 136)
Motor / Electricity	4 KW 400V 50 HZ 3-PH
Radial Crimp force	350 tons
Opening with dies	Ø Die + 54mm (Press path + 15mm)
Opening without dies	180mm
Length of master dies	120mm
Machine Dimensions (mm)	Width: 800 x Depth: 440 x Height: 800
Net Weight (with oil HV32, no dies)	235 kgs
Standard Packing (for transport)	Wood crate conform to NIMP15 regulation Crate dimensions: 110x78x110cms, Gross Weight (with standard die package 11 sets): 300 kgs
Noise Level	< 70 dB(A)

**DIES INCLUDED IN STANDARD DIE PACKAGE  
11 SETS FOR HOSES 1/4" - 2"**

**PRICE FOR MACHINE**

**£9,904.13 + VAT**

NO DIE INCLUDED

SELECT DIES FROM TABLE BELOW

PART NO.	DIE SIZE Ø	HOSE SIZE	NETT. PRICE	
			£ STERLING	€ EUROS
FF60-DIE-06	6	*BY MAN	£231.05	€ 267.56
FF60-DIE-08	8	*BY MAN	£231.05	€ 267.56
FF60-DIE-10	10	*BY MAN	£176.09	€ 203.91
FF60-DIE-12	12	*BY MAN	£176.09	€ 203.91
FF60-DIE-15	15	*BY MAN	£176.09	€ 203.91
FF60-DIE-18	18	**1/4"	£176.09	€ 203.91
FF60-DIE-21	21	**3/8"	£176.09	€ 203.91
FF60-DIE-24	24	**1/2"	£176.09	€ 203.91
FF60-DIE-27	27	**5/8"	£176.09	€ 203.91
FF60-DIE-30	30	**3/4"	£176.09	€ 203.91
FF60-DIE-33	33	*BY MAN	£176.09	€ 203.91
FF60-DIE-36	36	*BY MAN	£231.05	€ 267.56
FF60-DIE-39	39	**1"	£176.09	€ 203.91
FF60-DIE-42	42	*BY MAN	£231.05	€ 267.56
FF60-DIE-45	45	*BY MAN	£176.09	€ 203.91
FF60-DIE-48	48	*BY MAN	£176.09	€ 203.91
FF60-DIE-51	51	**1 1/4"	£176.09	€ 203.91
FF60-DIE-54	54	*BY MAN	£231.05	€ 267.56
FF60-DIE-57	57	**1 1/2"	£176.09	€ 203.91
FF60-DIE-62	62	*BY MAN	£231.05	€ 267.56
FF60-DIE-66	66	**2"	£176.09	€ 203.91
FF60-DIE-70	70	*BY MAN	£310.00	€ 358.98
FF60-DIE-73	73	*BY MAN	£503.84	€ 583.45
FF60-DIE-80	80	*BY MAN	£503.84	€ 583.45
FF60-DIE-86	86	*BY MAN	£503.84	€ 583.45
FF60-DIE-90	90	*BY MAN	£503.84	€ 583.45
FF60-DIE-95	95	*BY MAN	£503.84	€ 583.45
FF60-DIE-122	122	*BY MAN	£503.84	€ 583.45
FF60-DIE-130	130	*BY MAN	£503.84	€ 583.45
FF60-DIE-136	136	*BY MAN	£503.84	€ 583.45

\*\*The hose sizes stating hose size in table above are for use with Flowfits Vincke Hydraulic Hose!

\*BY MAN = By Manufacturer, Hose size determined by hose manufacturers crimping data- Please check with YOUR hose supplier!

# Accessories for Hose Crimpers

## FF-994



### Support Bench with 12 Die Storage & 2 Shelves, Suitable for Electric Hose Crimpers FF30, 40, 40-DC and 60

An ergonomic support bench suitable for the following Hose Crimper machines : FF 30, 40, 40-DC & FF60° The design of this Storage bench provides the operator with both an ideal working height and an ideal location of its die selection. Includes a 12 die storage holder and 2 shelves, which can be practical to store lubricant, tools, first aid kit, user manual or special dies.

Price does not include Hose Crimper.

PRICE

**£530.34 +VAT**

## FF-1338



### STORAGE

The Die Storage Panel is a practical and economic solution to store up to 12 sets of dies. The panel has 4 holes in each corner so that it can easily be fixed on a wall or on an existing bench nearby the hose crimping machine. The Storage panel will also bring additional die storage capacity when the die holders of your Support Bench (FF-994) are already full.

Dimensions: 600x550x200mm

Net Weight: 7,5 kg

PRICE

**£187.69 +VAT**

## FF-1174



### QUICK CHANGE

Magnetic gun shape tool for extraction and insertion of dies on Flowfit hose crimpers. The Quick Die Change Tool is a robust aluminium magnetic tool allowing quick die change on all our hose crimping machines. The gun shape makes this tool easy to handle, and the system makes the die change process safe without any risk to break die pins. In order to store your sets of dies, the QCT is to be used either with Individual Die Racks, or with a Wall Panel Die Rack (FF-1338) or with a Storage Bench (FF-994).

PRICE

**£384.04 +VAT**



# Mobile Van Solutions

## FF30-DC / 130T

### Crimping Machine for Mobile Van for hoses up to 1 1/2" (DN38, -24)

Compact, ultra-light, Simple and easy to use hose crimping machine.

Simple and economy hose crimping machine with high precision, large opening and perfect geometry results. Crimp force 130 tons, Universal hose crimper.

Crimps up to 1 1/2" Hose



#### PRODUCT FEATURES

- COMPACT & LIGHT WEIGHT BECAUSE OF ALUMINIUM HEAD
- EASY MAINTENANCE AND SERVICING
- CAPACITY UP TO 4-SP - 1 1/4"

#### TECHNICAL SPECIFICATION

Max Capacity	2-SN: 1 1/2" (DN38, -24) 4-SP/R12: 1 1/4" [DN32, -20] R13/R15/4-SH/Interlock: 1" [DN25, -16] Max. size for assembly with 2 x 90° elbows: max. 3/4" [DN 19] Max Crimp Range: (70mm with Dies No. 66)
Motor/Electrics	2000W – 12V DC Must be Connected to 12V DC Battery 250 Amp/ Hour. Battery is not supplied with machine
Radial Press Force	130 Tons
Opening	Ø Die + 28mm
Press Path	Ø Die + 12mm
Opening without Dies	98mm
Master Die Shoe Length	75mm
Dimensions	Width : 630mm Depth : 450mm Height : 590mm
Net Weight (with full oil tank, w/o dies)	60 KG
Packing	Wooden crate conform to ISPM15 Crate size : 58x70x75cms Gross weight [with 5 sets of dies]: 95 kgs
Noise Level	< 70 dB[A]

#### PRICE FOR MACHINE

**£3,423.61 +VAT**

NO DIE INCLUDED

SELECT DIES FROM TABLE BELOW

PART NO.	DIE SIZE Ø	HOSE SIZE	NETT. PRICE	
			£ STERLING	€ EUROS
FF25-DIE-06	6	*BY MAN	£231.05	€ 267.56
FF25-DIE-08	8	*BY MAN	£231.05	€ 267.56
FF25-DIE-10	10	*BY MAN	£176.09	€ 203.91
FF25-DIE-12	12	*BY MAN	£176.09	€ 203.91
FF25-DIE-15	15	*BY MAN	£176.09	€ 203.91
FF25-DIE-18	18	**1/4"	£176.09	€ 203.91
FF25-DIE-21	21	**3/8"	£176.09	€ 203.91
FF25-DIE-24	24	**1/2"	£176.09	€ 203.91
FF25-DIE-27	27	**5/8"	£176.09	€ 203.91
FF25-DIE-30	30	**3/4"	£176.09	€ 203.91
FF25-DIE-33	33	*BY MAN	£176.09	€ 203.91
FF25-DIE-36	36	*BY MAN	£231.05	€ 267.56
FF25-DIE-39	39	**1"	£176.09	€ 203.91
FF25-DIE-42	42	*BY MAN	£231.05	€ 267.56
FF25-DIE-45	45	*BY MAN	£176.09	€ 203.91
FF25-DIE-48	48	*BY MAN	£176.09	€ 203.91
FF25-DIE-51	51	**1 1/4"	£176.09	€ 203.91
FF25-DIE-57	57	**1 1/2"	£231.05	€ 267.56

\*\*The hose sizes stating hose size in table above are for use with Flowfits Vincke Hydraulic Hose!

\*BY MAN = By Manufacturer, Hose size determined by hose manufacturers crimping data- Please check with YOUR hose supplier!

## FFS30-DC

### Hose Crimping Kit with Splitter Head, 12V Power Pack and Remote Control Box

This crimper kit is ideal for a mobile van with it being light weight and compact.

The crimp head, power pack and remote control box are all splitted in order to optimise the setup of the van to balance the weights in the vehicle.

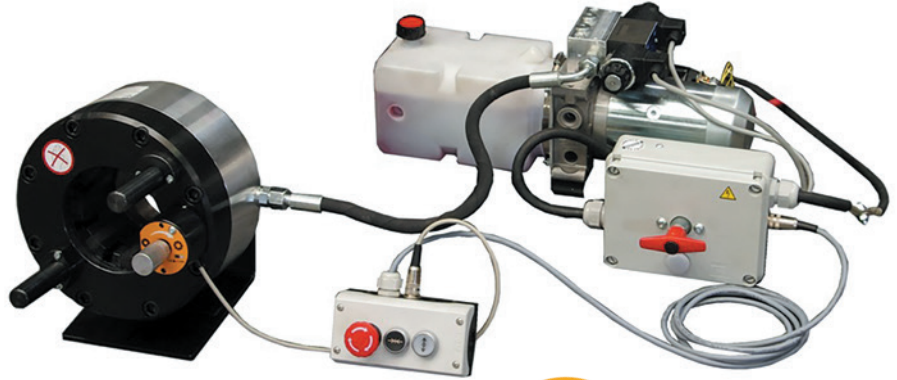

**Crimps up to 1 1/2" Hose**

#### PRODUCT FEATURES

- CAPACITY UPTO 1 1/2"
- ULTRA COMPACT AND LIGHT WEIGHT HEAD AND POWER PACK ON
- EASY TO FIX SUPPORTS

#### TECHNICAL SPECIFICATION

Hose Capacity	2-SN: 1 1/2" (DN38,-24) 4-SP/4-SH/R12: 1 1/4" .. [DN32, -20] R13/R15/Interlock: 1 " [DN25; -16] Limit with 2 x 90° elbows: max. 1" [DN25] Max Crimp Range: (70mm with Dies No. 66)
Motor/Electrics	2000W – 12V DC Connect to battery 250 AMP/Hour, Battery is not included
Crimp Force	135 Tons
Opening	Ø Die + 28mm
Press Path	Ø Die + 12mm
Opening without Dies	98mm
Master Die Shoe Length	75mm
Dimensions	Head only on bracket: Ø 260, H = 290, P = 330 Power Pack + Electrical Panel: 500 x 280 x 300 Remote Control Box: 160 x 85 x 90
Net Weight (with full oil tank, w/o dies)	58 KG
Packing	Wooden crate conform to ISPM15 Crate size : 58x70x75cms Gross weight [with 5 sets of dies]: 90 kgs
Noise Level	< 80 dB[A]

#### PRICE FOR MACHINE

**£3,423.61 +VAT**

NO DIE INCLUDED

SELECT DIES FROM TABLE BELOW

PART NO.	DIE SIZE Ø	HOSE SIZE	NETT. PRICE	
			£ STERLING	€ EUROS
FF25-DIE-06	6	*BY MAN	£231.05	€ 267.56
FF25-DIE-08	8	*BY MAN	£231.05	€ 267.56
FF25-DIE-10	10	*BY MAN	£176.09	€ 203.91
FF25-DIE-12	12	*BY MAN	£176.09	€ 203.91
FF25-DIE-15	15	*BY MAN	£176.09	€ 203.91
FF25-DIE-18	18	**1/4"	£176.09	€ 203.91
FF25-DIE-21	21	**3/8"	£176.09	€ 203.91
FF25-DIE-24	24	**1/2"	£176.09	€ 203.91
FF25-DIE-27	27	**5/8"	£176.09	€ 203.91
FF25-DIE-30	30	**3/4"	£176.09	€ 203.91
FF25-DIE-33	33	*BY MAN	£176.09	€ 203.91
FF25-DIE-36	36	*BY MAN	£231.05	€ 267.56
FF25-DIE-39	39	**1"	£176.09	€ 203.91
FF25-DIE-42	42	*BY MAN	£231.05	€ 267.56
FF25-DIE-45	45	*BY MAN	£176.09	€ 203.91
FF25-DIE-48	48	*BY MAN	£176.09	€ 203.91
FF25-DIE-51	51	**1 1/4"	£176.09	€ 203.91
FF25-DIE-57	57	**1 1/2"	£231.05	€ 267.56

\*\*The hose sizes stating hose size in table above are for use with Flowfits Vincke Hydraulic Hose!

\*BY MAN = By Manufacturer, Hose size determined by hose manufacturers crimping data- Please check with YOUR hose supplier!

## FFC30-DC

### Hydraulic Hose Cutter - Max 2" 1 & 2-SN Intermittent use in Mobile Vans, 12V DC operated

This cutter was especially designed for use in Hose Repair vans using 12V DC power supply.

Simple, Compact, Stable, Light, equipped with a slotted disc, it is the ideal machine for hose cutting in mobile vans. The 'Delrin' cutting bed surface allows the hose to move nicely to the blade without binding.

Easy to use with the start button on the handle.



**PRICE**

**£1,741.89 +VAT**

### TECHNICAL SPECIFICATION

Max Hose Size:	1 & 2-SN: 2" (DN50) 4-SP or 4-SH: 1 1/4" (DN32) 6-SP/R13/R15: 1" (DN25)
Max hose OD:	Ø 65mm
Cutting Disc Details:	Ø 250 x 25 x 3mm (Slotted disc is standard, on option we can supply smooth bore cutting discs)
Motor:	2000W – 12V DC To be connected to auxiliary 12V DC battery with 250 Amp fuse in line and 25mm <sup>2</sup> electric cable. Battery, fuse and cables are not supplied with machine.
Dimensions:	Width: 500 x Depth 500 x Height 400mm
Net weight:	35 Kg

# Production Hose Crimpers

## FFKP-150

### Production Hose Crimper Max. 2" (DN50)

Compact, silent and fast production hose crimping machine for companies making serial hose assemblies.

The large opening and slim frame allow easier access for elbows, long drops or complex bent fittings. The machine is equipped with an electronic touch screen interface and silent hydraulics.

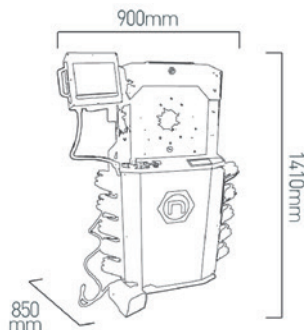

#### PRODUCT FEATURES

- FAST CYCLE
- SLIM FRAME
- LARGE OPENING AND SILENT HYDRAULICS

#### OPTIONAL

- PRESSURE MONITORING
- OIL COOLING
- DATA RECORD AND TRANSFER



#### TECHNICAL SPECIFICATION

Indicative Hose capacity:	2-SN & industrial: 2" (DN50) 4-SP/R12: 1 1/4" (DN32) R13/R15/4-SH or Interlock: 1" (DN25) Max. hose Diameter Ø76mm 1" (with die N°70)
Motor/Electrics	5.5KW - 230/400V 3-PH 50Hz
Radial Press Force	140 tons
Opening	Ø Die size+ 45mm
Opening without dies	125mm
Master die shoe length:	80mm
Controls:	Touch screen HMI Intuitive crimp software with semi auto mode, memory of crimp parameters, automatic die selection, quick change, cycle counter.
Speed:	Closing speed: 22mm/s Crimp speed: 3.7mm/s Opening speed: 66mm/s Number of cycles/hour: 2000 (in semi-auto mode, die Ø+10mm)
Dimensions:	Width: 630mm / Depth: 450mm / Height: 590mm
Net weight (with full oil tank):	720 kg (180L)
Packing:	Crate size: 90x85x141cms / Gross weight: 830 kgs
Noise level:	< 64 dB(A)

#### PRICE FOR MACHINE

**£19,811.41 +VAT**

NO DIE INCLUDED

SELECT DIES FROM TABLE BELOW

PART NO.	DIE SIZE Ø	HOSE SIZE	NETT. PRICE	
			£ STERLING	€ EUROS
FF25-DIE-06	6	*BY MAN	£231.05	€ 267.56
FF25-DIE-08	8	*BY MAN	£231.05	€ 267.56
FF25-DIE-10	10	*BY MAN	£176.09	€ 203.91
FF25-DIE-12	12	*BY MAN	£176.09	€ 203.91
FF25-DIE-15	15	*BY MAN	£176.09	€ 203.91
FF25-DIE-18	18	**1/4"	£176.09	€ 203.91
FF25-DIE-21	21	**3/8"	£176.09	€ 203.91
FF25-DIE-24	24	**1/2"	£176.09	€ 203.91
FF25-DIE-27	27	**5/8"	£176.09	€ 203.91
FF25-DIE-30	30	**3/4"	£176.09	€ 203.91
FF25-DIE-33	33	*BY MAN	£176.09	€ 203.91
FF25-DIE-39	39	**1"	£176.09	€ 203.91
FF25-DIE-48	48	*BY MAN	£176.09	€ 203.91
FF25-DIE-51	51	**1 1/4"	£176.09	€ 203.91
FF25-DIE-57	57	**1 1/2"	£231.05	€ 267.56
FF25-DIE-66	66	**2"	£231.05	€ 267.56

\*\*The hose sizes stating hose size in table above are for use with Flowfits Vincke Hydraulic Hose!

\*BY MAN = By Manufacturer, Hose size determined by hose manufacturers crimping data- Please check with YOUR hose supplier!

# Hose Cutters

## FFC-25

### Hose Cutting Machine Max. 1" 4-SP (DN25,16)

High quality, compact and silent hose cutter with brake motor and HSS steel cutting disc. Ideal for Agri machine workshops. The machine can be connected to an optional suction kit.

Additionally, a bench support, measuring cutting rails and de-coilers are also available in our range of accessories for hose cutters.

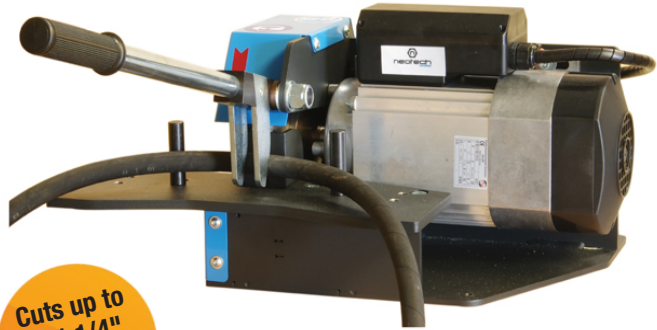

Cuts up to  
to 1 1/4"  
Hose

#### PRICE

**£1,097.25 +VAT**

#### PRODUCT FEATURES

- 220V COMPACT & SILENT HOSE CUTTER
- INCLUDES BRAKE MOTOR FOR OPTIMAL SAFETY

#### OPTIONAL

- SMOKE SUCTION KIT
- BENCH SUPPORT

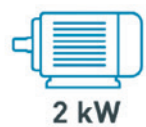
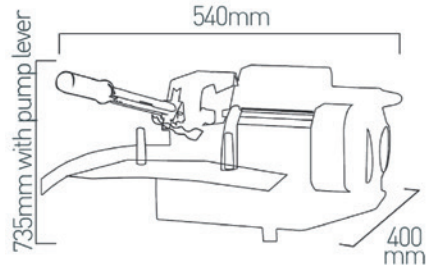

## TECHNICAL SPECIFICATION

Hose capacity: (Intermittent use)	Hoses 1-SN & 2-SN: 1 1/4" (DN32) Hoses 4-SP & 4-SH: 1" (DN25)
Max hose OD:	Ø 50mm
Cutting disc size:	Ø 210mm (Smooth edge, HSS steel)
Rotation speed:	2,820 rpm
Net weight:	37 Kg
Motor:	2KW-230V 50Hz 1-PH with Brake available in 110V 1-PH 60Hz on request
Dimensions:	Width: 540mm Depth: 400mm Height: 735mm
Suction connection:	Ø 50mm
Packing:	Wooden crate conform to ISPM15 Crate size: 60x80x50cms Gross weight: 50kgs

**FFC-30**

**Hose Cutting Machine  
Max. 2" 2-SN (DN50,32)**

Versatile and compact benchtop hose cutter equipped with a powerful brake motor and a HSS steel slotted blade. It is ideal for construction machinery or Agri machinery workshops as it will cut multi-spiral hoses up to 1 1/2". Optionally the machine can be connected to a simple smoke suction unit.

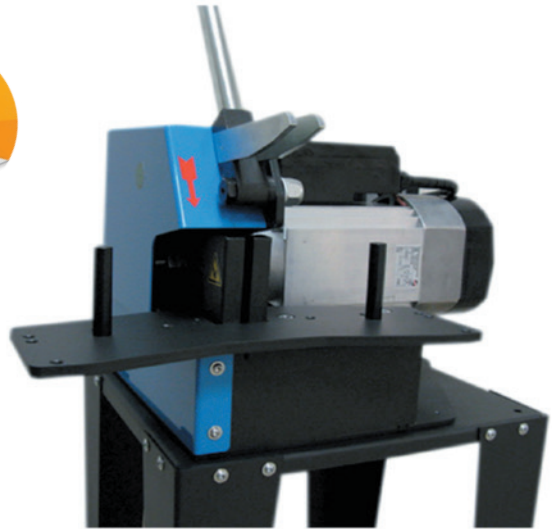

**PRODUCT FEATURES**

- COMPACT HOSE CUTTER WITH BRAKE MOTOR
- HSS STEEL DISC FOR MULTISPIRAL HOSE MAX. DN38

**OPTIONAL**

- SMOKE SUCTION KIT
- BENCH SUPPORT

**PRICE**

**£2,161.49 +VAT**

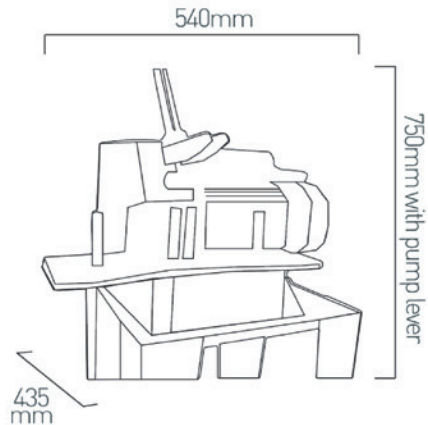

**TECHNICAL SPECIFICATION**

Hose capacity: (Intermittent use)	Hoses 2-SN: 2" (DN50) Hoses 4-SP & 4-SH: 1 1/2" (DN38) R13/R15/6 - Multispirals: 1 1/4" (DN32)
Max hose OD:	Ø 65mm
Cutting disc size:	Ø 275mm (Slotted edge, HSS steel disc)
Rotation speed:	2,720 rpm
Net weight:	45 Kg
Motor:	3.8KW-400V 50Hz 3-PH + N with motor brake available in 230V 1-PH or 230V 3-PH on request
Dimensions:	Width: 540mm Depth: 435mm Height: 350mm -Height with pump lever: 750mm
Suction connection:	Ø 50mm
Packing:	Crate size: 60x80x50cms Gross weight: 55kgs

## FFC-40

### Hydraulic Hose Cutting Machine Max.2" Multispiral

Powerful hose cutter for easy cutting of R15 hoses up to 1 1/2" and multi-spiral hoses up to 2". A special force multiplier hand lever makes the cutting action easier for the operator.

It will cut a R15 1 1/2" hose in less than 5 seconds. The machine comes with a powerful 5KW brake motor and a 350mm HSS Steel Slotted Blade. Optionally the machine can be connected to a simple smoke suction unit.

**Cuts up to 2 1/2" Hose**

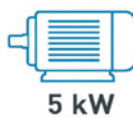

#### PRODUCT FEATURES

- POWERFUL HOSE CUTTER WITH BRAKE MOTOR AND EFFORTLESS PUSHER

#### OPTIONAL

- SMOKE SUCTION KIT + SPARK BARRIER
  - BENCH SUPPORT
  - CUTTING RAIL
  - MEASURING DEVICE

#### PRICE

**£3,273.46 +VAT**

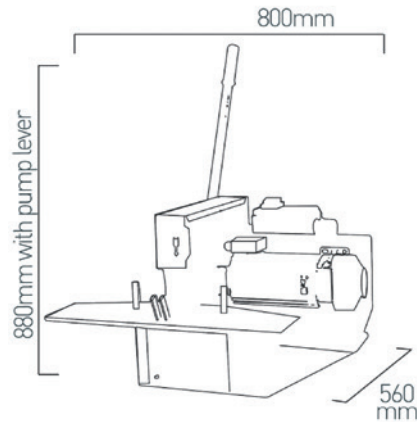

### TECHNICAL SPECIFICATION

Hose capacity: (Intermittent use)	Hoses 2-SN: 2 1/2" (DN63) Hoses 4-SP & 4-SH: 2" (DN50) R13/R15: 1 1/2" (DN38)
Max hose OD:	Ø 95mm
Cutting disc size:	Ø 350mm (Slotted edge, HSS steel disc)
Rotation speed:	2,820 rpm
Net weight:	70 Kg
Motor:	5KW-400V 50Hz 3-PH with brake available in 230V 3-PH on request
Dimensions:	Width: 800mm Depth: 560mm Height with pump lever: 880mm
Packing:	Crate size: 120x60x100cms Gross weight: 90kgs

# Hose Skiving

## FFSK1

**Hand Skiving Set Capacity:  
1 1/4" (Set 6/32) or 2" (Set 6/50)**

Simple Hand Skiving Set, to be loaded in a vice. Different versions are available up to 1 1/4" with or without internal skivers and also up to 2" with or without internal skivers. It is ideal for mobile workshops.



**FFSK1 - 6/32 EI PRICE**

**£833.91 +VAT**

**FFSK1 - 6/50 EI PRICE**

**£1043.62 +VAT**

### HAND SKIVING FOR EXTERNAL AND INTERNAL HOSE SKIVING

- SET DELIVERED IN A SUITCASE
- CRANK TO BE USED WITH A VICE (VICE NOT INCLUDED)
- IDEAL FOR MOBILE HOSE VANS OR BEGINNERS

### TECHNICAL SPECIFICATION

	FFSK1 - 6/32 EI	FFSK1 - 6/50 EI
Capacity:	1SN-2SN-3TE: 1 1/4" (DN32) 4-SP: 1 1/4" (DN32) R13/R15/4-SH: 1 1/4" (DN32)	1SN-2SN-3TE: 2" (DN50) 4-SP: 2" (DN50) R13/R15/4-SH: 2" (DN50)
Use:	Crank to be used in a vice	
Packing:	Suitcase 450x350x110mm (8.5 kg)	Suitcase 450x350x110mm + 2 boxes (12 Kgs) Possibility to order a 2nd suitcase to store the 5 internal skivers
Composition of the set	FFSK1-6/32-EI (for hoses up to 1. 1/4"): 1 x External Knife Holder ESK6-32 + 8 mandrels 3 x internal skivers ISK19,25,32	FFSK1 - 6/50- EI (for hoses up to 2") 2 x External knife holders ESK6-32 + ESK38- 50 + 10 mandrels 5 x internal skivers: ISK19,25,32,38,50
Gross Weight	Available without internal skivers: FFSK1-6/32-E 8,5 kgs (with 3 internal skivers)	Available without internal skivers: FFSK1-6/50 E 12 kgs (with 5 internal skivers)



## FFSK50 2"

### Skiving machine for rubber hoses up to 2" 6- Spiral

Compact Electric Hose skiving machine with clear plexiglass guard and safety features.

The machine is equipped with a switch to change the direction of the rotation and a foot switch. External skiving is done with pre-adjustable tools ESK and Internal Skiving with pre-adjustable tools ISK. Machines with Simultaneous internal and external skiving are also available (NSK50-SIM)

Skiving up to 2" Hose



**PRICE**

**£2,255.00 +VAT**

### EXTERNAL AND INTERNAL SKIVING

- MACHINE CONFORM TO CE SAFETY RULES
- HIGH QUALITY SKIVING THANKS TO SPECIAL KNIFE DESIGN
- SUPER CLEAR VISION THANKS TO ALL-PLEXY PROTECTION BOX

### TECHNICAL SPECIFICATION

Hose capacity:	2SN: 2" (DN50) 4-SP: 2" (DN50) 6-SP: 2" (DN50)
Motor:	0,55KW-400V 50Hz 3-PH
Max hose OD:	Ø 95mm
Suppress Line Cutting Disc Size:	Ø 350mm (Slotted edge, HSS steel disc)
Rotation speed:	370 rpm Option: Speed Adjuster 0-400 rpm Standard Control: Foot Switch + Rotation direction switch
Dimensions:	Width: 240 x Depth 760 x Height 330mm
Net weight:	45 Kg
Packing:	Pallet 55x70x75cms, 55 Kgs
Skiving Tools / Available Options	External Skiving Tools ESK (Standard Pack includes 2 x ESK): ESK6-25 for hose 1/4" to 3/4" ESK32-50 for hose 1 1.4" to 2"  Internal Skivers available (Optional): ISK Ø16,19,25,32,38,50  Other Options: Individual External Skiving Heads (1 per hose size) Support table with bin Hose clamping system for increased operator safety Simultaneous internal + external skiving

**FFSK50-ST**

**Skiving machine for rubber hoses up to 2" 6- Spiral with support bench**

Compact Electric Hose skiving machine with clear plexiglass guard and safety features.

The machine is equipped with a switch to change the direction of the rotation and a foot switch. External skiving is done with pre-adjustable tools ESK and Internal Skiving with pre-adjustable tools ISK. Machines with Simultaneous internal and external skiving are also available (NSK50-SIM)

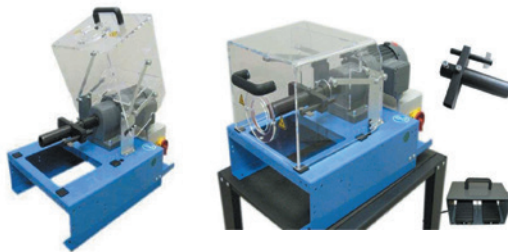

Skiving up to 2" Hose



**PRICE**  
**£4,699.88 +VAT**

**EXTERNAL AND INTERNAL SKIVING**

- MACHINE CONFORM TO CE SAFETY RULES
- HIGH QUALITY SKIVING THANKS TO SPECIAL KNIFE DESIGN
- SUPER CLEAR VISION THANKS TO ALL-PLEXY PROTECTION BOX
- SUPPORT BENCH WITH BIN

**TECHNICAL SPECIFICATION**

Hose capacity:	2SN: 2" (DN50) 4-SP: 2" (DN50) 6-SP: 2" (DN50)
Motor:	0,55KW-400V 50Hz 3-PH
Max hose OD:	Ø 95mm
Suppress Line Cutting Disc Size:	Ø 350mm (Slotted edge, HSS steel disc)
RRotation speed:	370 rpm Option: Speed Adjuster 0-400 rpm Standard Control: Foot Switch + Rotation direction switch
Dimensions:	Width: 240 x Depth 760 x Height 330mm
Net weight:	45 Kg
Packing:	Pallet 55x70x75cms, 55 Kgs
Skiving Tools / Available Options	External Skiving Tools ESK (Standard Pack includes 2 x ESK): ESK6-25 for hose 1/4" to 3/4" ESK32-50 for hose 1 1.4" to 2"  Internal Skivers available (Optional): ISK Ø16,19,25,32,38,50  Other Options: Individual External Skiving Heads (1 per hose size) Hose clamping system for increased operator safety Simultaneous internal + external skiving

# Peripherals

## FFHC125

Manual Hose Coiler



PRICE

**£1,058.75 +VAT**

## FFHC 125 E

Motorised Hose Coiler



PRICE

**£3,812.87 +VAT**

## FFHR 7C

Multi Hose Coiler



PRICE

**£975.00 +VAT**

Including high quality braking wheels

Central pin full steel bar 40 for better rigidity

Teflon washer under turntable to brake turntable according to coil weight

Easy adjustment of the coil ID tension

## TECHNICAL SPECIFICATION

	FFHC 125	FFHC 125 E	FFHR 7C
Max Total Loaded Weight	250 KG	250 KG	500KG
Dimensions (W X D X H)	1200 x 1200 x 900mm	1200 x 1200 x 900mm	1180 x 1000 x 2115mm
Plate Diameter	1200mm	1200mm	1000mm
Max Coil OD	1000mm	1000mm	850mm
Weight	40 KG	70 KG	100KG
Number of Plates	1	1	7
Colour	Black	Black	Blue / Weight
Electricity Rotation Speed	****	0.37 KW - 230V 1-PH, 0-35 RPM	****

# Hose and Tube Cleaning

## FFPL32 / FFPL50

### Decontamination of hoses and tubes by pneumatic launch of foam projectiles

Cleanliness of hydraulic circuits has become a major concern for all hydraulic professionals. A clean hydraulic circuit will increase the life expectancy of the equipment and components, in particular as the warranty to have a clean hydraulic system will protect the pump and sensitive hydraulic components such as proportional valves. Debris in the hydraulic circuits can also have major financial consequences in case of machine breakdowns.

Tubes and hoses are one of the components that can bring contamination into the circuit, in particular after the hose cutting and skiving process or deburring for tubes. The FFPL Cleaning Kit is an easy and portable solution to make sure your hoses and tubes are free of contamination.

How it works: A pneumatic gun shoots a foam projectile at high speed through the hose or tube. The foam projectile being slightly larger than the hose or tube ID, it will evacuate all debris or dust encountered on its way.

Various types of foam can be used for different applications. Universal foam pellets (MPP) will be used for hoses and tubes with no ends and with limited amount of debris. Special Tube pellets with grinding and abrasive material are also available for tubes with heavier particles or cross sections. FFPL kits are available in 2 versions: FFPL32 for hose decontamination from size 3/16" up to 1 1/4", FFPL50 for hose decontamination for 3/16" up to 2".

Additional nozzles (e.g. for metric tubing), tools and projectiles are available for applications up to 4".



#### FFPL32-8N PRICE

**£741.13 +VAT**

#### FFPL50-10N PRICE

**£1,361.25 +VAT**

#### FFPL50-23N PRICE

**£1529.73 +VAT**

## TECHNICAL SPECIFICATION

Capacity:	Hose decontamination: 3/16" - 2" with FFPL50-10N Hose and Tube decontamination: 2" with FFPL50-23N
FFL32-8N:	Complete set including 1 1/4" Eco launcher and a range of 8 hose nozzles to over decontamination of hoses without ends on from 3/16" to 1 1/4"
FFPL50-10N:	Complete set including 2" launcher and a range of 10 hose nozzles to cover decontamination of hoses without ends on from 3/16" to 2"
FFPL50-23N:	Complete set including 2" Launcher, Adapter ring and a range of 23 nozzles to cover decontamination of the following hose and pipe types and sizes: -HOSE with no ends (1/4" - 2"): H06,08,10,13,16,19,25,32,38,50 -JIC ASSEMBLIES (1/4"-2"): J06,10,13,16,19,25,32,38,50 -FFORX ASSEMBLIES (-4 to -20)- HYDRAULIC TUBES (Imperial 1/4" - 2") : T06,08,10,13,16,19,22,25,32,38,50
Compressed air:	Connection to dry air .5 bar - 7.5 bar Flow: 1.6 m3/min) Quick coupling 1/2" delivered with the set
Projectiles:	Various style of projectiles are available (Standard, Tube, Abrasive, Grinding) For hoses : Multipurpose Projectiles are recommended (MPP) and available in starter kits (1 bag of projectile per hose size)
Recommendation:	OD of multipurpose projectiles should be 20% larger than hose ID

# Also Available

## FFOT-8D

### Side Feed Crimp Tool with 8 Dies for Hose or Cable Assembling C-Shape Crimping Tool with 8 Dies

The OT-8D-25 Crimping Tool is made to suit special hose or cable crimp applications with specific space or production requirements: Mix assemblies with bent tubes and rubber hoses, special bent fittings or long hose or cable lengths which cannot be crimped with traditional closed crimping heads.

The OT-8D-25 allows to side feed the hose into the crimp head and hence opens the possibility for automatic or robot feeding of the product to be crimped.

The OT-8D-25 crimp tool is extremely narrow and compact (120mm) so that it can fit ideally special machine integration or configurations.

The crimp force is limited to 25 Tons, which limits the use of this machine to light ferrule crimp used on products such as freon hose, power steering hoses, air or water hoses.

Thanks to an adjustable mechanical stop, this machine is very precise and offers high repeatable performance capacities in case CMK/CPK are required.



**PRICE**  
**£35,612.50 +VAT**

#### Precise and Reptitive Crimp Diameter- High CPK/CMK Performance

The crimp stop is mechanically controlled by an adjustable stop mounted on the cylinder so that the crimp stops exactly at the same position all the time. A pressure switch is associated to the stop so that in case of material OD variation the stop can be done by pressure to avoid over crimp. The pressure peak also indicates to the machine that the crimp is done.

#### Options Pneumatic Safety Guard

When used with an operator in front of the machine and a foot switch, we automatically equip the machine with a pneumatic guard to avoid any risk of injury (unless other specific controls and safety features are put in place and required by the customer- immaterial curtains, Double hand switch)

#### Fitting Positioning Tools

Located on the side of the head, we are able to design specific positioning tools to ensure that the fitting is correctly positioned before crimping.

## TECHNICAL SPECIFICATION

Crimp Capacity:	Minimum Crimp OD: 1.5mm (Cable) Maximum Crimp OD: 45mm
Cycle Time:	According to customer requirements and cycle time target: With pump 16L/min, cycle time = 6 seconds With double pump 24L+8L = 3 seconds
Radial Press Force:	25 KdaN @ 210 bar
Maximum Side Feed OD:	54mm
Max Die Length:	50mm
Noise Level:	According to hydraulic configuration and pump selected 68dB(A) to 63db(A)
Standard Measurement Control:	Adjustable mechanical stop on actioner cylinder with digital pressure switch
Head Dimension:	Width: 120 x Depth 325 x Height 896mm
Net weight:	Head Alone with Cylinder: 160KG

# Hose Crimper Kits

## Flowfit Portable Hand Hose Crimper Starter Kit - ZZ009373

Light portable hand crimper for on-site hose repairs.

The NKH16 crimper is the ideal tool for ON-SITE hydraulic hose repair jobs.

Typically used in agriculture, forestry, road works either loaded at the back of the mobile van or in a workshop as the emergency hose repair tool.

The machine is equipped with a resistant and robust 350 bar, and a simple adjustment vernier.

The double speed hand pump limits the number of pump strokes needed to achieve a crimp.

This kit comes with 3 different Die sets and a range of hose and fittings to suit this crimper.

**Crimps up to 1" Hose**



### PRICE

**£1,584.70 +VAT**

DIE SETS	FERRULES	STRAIGHT FEMALE FITTINGS	45°DEGREE FEMALE FITTINGS	90°DEGREE FEMALE FITTINGS	HYDRAULIC HOSE
1 X 1/4"	16 X 1/4"	8 X 1/4" BSP	4 X 1/4" BSP	4 X 1/4" BSP	15 METRES X 1/4"
1 X 3/8"	16 X 3/8"	8 X 3/8" BSP	4 X 3/8" BSP	4 X 3/8" BSP	15 METRES X 3/8"
1 X 1/2"	16 X 1/2"	8 X 1/2" BSP	4 X 1/2" BSP	4 X 1/2" BSP	15 METRES X 1/2"

Please note this includes 1/4", 3/8" and 1/2" Dies sets based on the Flowfit hose mentioned, if you require other sizes please see individual listing of Die sets which can be seen on the website.

## TECHNICAL SPECIFICATION

Capacity : For hydraulic hose crimping and intermittent use	2-SN: 1" (DN25; -16) 4-SP: 1/2" (DN13; -10) Limit for assembly with 2 x 90° elbows : max. 1/2" (DN13)
Hand Pump	Double Speed Pump with handle, delivered with oil HV32 Max. 350 bar
Radial Crimp force	80 tons
Die opening	Ø Die. + 20mm
Opening without dies	59 mm
Length of master die shoe	56 mm
Available die sizes (mm) *Sets of dies included in standard Pack 6 sets	Ø 6,10,12,15*,18*,21*,24*,27*,30* Master dies are used as Die N°39 to crimp 1" hoses
Dimensions of machine	Width: 300mm Depth: 220mm Height: 400mm
Net weight (with oil, without dies)	28 kgs
Packing details (for transport purposes)	Each Machine is packed in a wood crate suitable for long haul freight, conform to NIMP15 norms Dimension of packing : 26x41x48cms. Gross weight (with 6 sets of dies) : 35 kgs

## Flowfit Electric Hose Crimper Starter Kit, 220V, Crimp Force 130 Tonnes SKU - ZZ010599

This machine is compact, reliable, robust and easy to use and handle thanks to its low weight (65 kgs).

Included : 1 x Electric Hose Crimper, 2 x Side Protection Panels and a range of Hose and fittings.



**Crimps up to 1 1/4" Hose**

### PRODUCT FEATURES

- **COMPACT, EASY TO USE**
- **ECONOMICAL HOSE CRIMPER**
- **FRONT RACKINGS FOR DIE**
- **HIGH PRECISION**

### PRICE

**£3,790.00 +VAT**

**Flowfit Electric Hose Crimper Starter Kit Includes the following:**

1 x Electric Hose Crimper

DIE SETS	FERRULES	STRAIGHT FEMALE FITTINGS	45°DEGREE FEMALE FITTINGS	90°DEGREE FEMALE FITTINGS	HYDRAULIC HOSE
1 X 1/4"	16 X 1/4"	8 X 1/4" BSP	4 X 1/4" BSP	4 X 1/4" BSP	15 METRES X 1/4"
1 X 3/8"	16 X 3/8"	8 X 3/8" BSP	4 X 3/8" BSP	4 X 3/8" BSP	15 METRES X 3/8"
1 X 1/2"	16 X 1/2"	8 X 1/2" BSP	4 X 1/2" BSP	4 X 1/2" BSP	15 METRES X 1/2"
1 X 3/4"	16 X 3/4"	8 X 3/4" BSP	4 X 3/4" BSP	4 X 3/4" BSP	15 METRES X 3/4"
1 X 1"	16 X 1"	8 X 1" BSP	4 X 1" BSP	4 X 1" BSP	15 METRES X 1"

Please note this includes 1/4", 3/8", 1/2", 3/4" and 1" Dies sets based on the Flowfit hose mentioned, if you require other sizes please see individual listing of Die sets which can be seen on the website.

## TECHNICAL SPECIFICATION

Indicative Hose Capacity	2-SN: 11/2" [DN38; -24] 4-SP: 11/4" . [DN32, -20] R13/R15/Interlock: 1" [DN25; -16] Max. size for assembly with 2 x 90° elbows: max. 3/4" [ON 19]
Motor/Electrics	2.2 kW -400V3-PH + Earth+ Neutral 50Hz 2.2 kW - 230V 1-PH 50Hz 1.5 kW - 11 0V 1-PH 60Hz 2 kW-12 VDC [NK30-DC12]
Radial Press Force	130 Tonnes
Opening	Ø mors + 28mm [working stroke:+ 12mm]
Opening without Dies	98mm
Master Die Shoe Length	75mm
Available Die Sizes (mm)	Ø 6/8/10/12/15/18/21/24/27/30/33/36/39/45/48/51/57/66 mm
Dimensions	Width : 630mm Depth : 450mm Height : 590mm
Net Weight (with full oil tank, w/o dies, hose and fittings)	68 KG
Noise Level	< 70 dB[A]

## Flowfit 5 Die, Electric Hose Crimper Kit, Crimp Force 130 Tons SKU - ZZ010776

This machine is compact, reliable, robust and easy to use and handle thanks to its low weight (65 kgs).

Included : Electric Hose Crimper, 5 Die Set, Support Bench, Foot Switch & Quick Die Change Tool, Available as 220 or 400V, Radial Force 140 Tons and handle thanks to its low weight (65 kgs).

Included : 1 x Electric Hose Crimper, 2 x Side Protection Panels and a range of Hose and fittings.



### PRODUCT FEATURES

- COMPACT, EASY TO USE
- ECONOMICAL HOSE CRIMPER
- FRONT RACKINGS, SUPPORT BENCH, FOOT SWITCH & QUICK DIE CHANGE TOOL
- \* HIGH PRECISION

### PRICE

**£4,778.43 +VAT**

## TECHNICAL SPECIFICATION

Indicative Hose Capacity	2-SN: 11/2" [DN38; -24] 4-SP: 11/4 [DN32; -20] R13/R15/Interlock: 1" [DN25; -16] Max. size for assembly with 2 x 90° elbows: max. 3/4" [ON 19]
Motor/Electrics	2.2 kW -400V3-PH + Earth+ Neutral 50Hz 2.2 kW - 230V 1-PH 50Hz 1.5 kW - 11 0V 1-PH 60Hz 2 kW-12 VDC [NK30-DC12]
Radial Press Force	130 Tonnes
Opening	Ø mors + 28mm [working stroke:+ 12mm]
Opening without Dies	98mm
Master Die Shoe Length	75mm
Available Die Sizes (mm)	Ø 6/8/10/12/15/18/21/24/27/30/33/36/39/45/48/51/57/66 mm
Dimensions	Width : 630mm Depth : 450mm Height : 590mm
Net Weight (with full oil tank, w/o extras)	68 KG
Noise Level	< 70 dB[A]

**5 Die Set Includes:**  
15/21/27/33/39mm Dies

#### Support Bench:

12 Die Storage, 2 Shelves

"Provides the operator with both an ideal working height and an ideal location of its die selection  
Can be practical to store lubricant, tools, first aid kit, user manual or special dies"

#### Foot Switch Control:

Allows operator to free their hands

#### Quick Die Change Tool:

Magnetic Tool for the extraction and insertion of Dies  
Easy to handle



## 8 Die, Electric Hose Crimper Kit, Crimp Force 140 Tons Product Sku: ZZ010774

This machine is compact, reliable, robust and easy to use and handle thanks to its low weight (65 kgs).

Included : Electric Hose Crimper, 8 Die Set, Support Bench, Foot Switch & Quick Die Change Tool, Available as 220 or 400V, Radial Force 140 Tons and handle thanks to its low weight (65 kgs).

Included : 1 x Electric Hose Crimper, 2 x Side Protection Panels and a range of Hose and fittings.



### PRODUCT FEATURES

- \* **COMPACT, EASY TO USE**
- \* **ECONOMICAL HOSE CRIMPER**
- \* **FRONT RACKINGS, SUPPORT BENCH, FOOT SWITCH & QUICK DIE CHANGE TOOL**
- \* **HIGH PRECISION**

### PRICE

**£5,168.51 +VAT**

## TECHNICAL SPECIFICATION

Indicative Hose Capacity	2-SN: 11/2" [DN38; -24] 4-SP: 11/4 [DN32, -20] R13/R15/Interlock: 1" [DN25; -16] Max. size for assembly with 2 x 90° elbows: max. 3/4" [ON 19]
Motor/Electrics	2.2 kW -400V3-PH + Earth+ Neutral 50Hz 2.2 kW - 230V 1-PH 50Hz 1.5 kW - 11 0V 1-PH 60Hz 2 kW-12 VDC [NK30-DC12]
Radial Press Force	130 Tonnes
Opening	Ø mors + 28mm [working stroke:+ 12mm]
Opening without Dies	98mm
Master Die Shoe Length	75mm
Available Die Sizes (mm)	Ø 6/8/10/12/15/18/21/24/27/30/33/36/39/45/48/51/57/66 mm
Dimensions	Width : 630mm Depth : 450mm Height : 590mm
Net Weight (with full oil tank, w/o extras)	68 KG
Noise Level	< 70 dB[A]

**8 Die Set Includes:**  
15/18/21/24/27/30/33/39/45/48mm Dies

**Support Bench:**  
12 Die Storage, 2 Shelves  
"Provides the operator with both an ideal working height and an ideal location of its die selection  
Can be practical to store lubricant, tools, first aid kit, user manual or special dies"

**Foot Switch Control:**  
Allows operator to free their hands

**Quick Die Change Tool:**  
Magnetic Tool for the extraction and insertion of Dies  
Easy to handle



# FLOWFIT®

## HYDRAULIC QUICK RELEASE COUPLINGS

- USED TO QUICKLY CONNECT AND/OR DISCONNECT HYDRAULIC LINES.
- AVAILABLE IN A WIDE RANGE OF SIZES & SPECIFICATIONS TO EASILY FIT YOUR HYDRAULIC SYSTEMS COMPONENTS.
- CHOOSE BETWEEN ISO A, FLAT FACE OR TRAILER BRAKE QUICK RELEASE COUPLINGS.
- PLASTIC DUST CAPS ALSO AVAILABLE TO PROTECT AND STOP DIRT FROM ENTERING THE QRC'S AND YOUR HYDRAULIC CIRCUIT.
- OTHER RANGES AVAILABLE, PLEASE SEE NEW CATALOGUE!

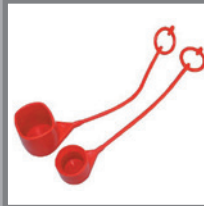







# FLOWFIT®

## HYDRAULIC ADAPTORS

- ENSURES THAT HOSE ASSEMBLIES, VALVES AND PORTS ARE CONNECTED IN THE MOST EFFICIENT WAY.
- HELPS CONTAINS AND DIRECTS THE FLOW OF HYDRAULIC FLUID.
- PREVENTS LEAKS AND MAINTAINS PRESSURE.
- CHOOSE BETWEEN MALE AND FEMALE ADAPTORS, TEE'S, ELBOWS AND SWEPTS.
- EACH OF OUR ADAPTORS ARE AVAILABLE WITH MALE AND/OR FEMALE ENDS.
- WE OFFER A COMPREHENSIVE RANGE WHICH INCLUDES BSP, BSPT, ORFS, NPFT, JIC, METRIC & SAE.



		<b>FFH16</b>		<b>FFH25</b>		<b>FF25</b>		<b>FF-30</b>		<b>FF30-PRO</b>		<b>FF-40</b>		<b>FF40-PRO</b>		<b>FF60</b>		<b>FFKP-150</b>
<b>CRIMPS FORCE (TONS)</b>	80		137		120		130		135		200		240		350		150	
<b>CAPACITY 1 &amp; 25N INDUSTRIAL</b>	1" (DN25)		2" (DN50)		1 1/2" (DN38)		1 1/2" (DN38)		2" (DN50)		2" (DN50)		2" (DN50)		4" (DN100)		2" (DN50)	
<b>CAPACITY 4-SP</b>	1/2" (DN12)		1 1/4" (DN32)		1" (DN25)		1 1/4" (DN32)		1 1/4" (DN32)		1 1/2" (DN38)		2" (DN50)		2" (DN50)		1 1/4" (DN32)	
<b>CAPACITY 6-SP</b>	1/2" (DN12)		3/4" (DN19)		3/4" (DN19)		1" (DN25)		1" (DN25)		1 1/4" (DN32)		1 1/4" (DN32)		2" (DN50)		2" (DN50)	
<b>CAPACITY INTERLOCK</b>	N/A		3/4" (DN19)		3/4" (DN19)		1" (DN25)		1" (DN25)		1 1/4" (DN32)		1 1/4" (DN32)		2" (DN50)		1" (DN25)	
<b>MAX RANGE (MM)</b>	44		70		70		70		70		76		76		145		76	
<b>MAX OPENING (MM), DIE Ø+</b>	20		18		18		28		28		38		38		52		45	
<b>PRESS PATH (MM)</b>	20		18		18		12		12		14		14		15		45	
<b>OPENING WITHOUT DIES (MM)</b>	59		98		98		98		98		118		118		182		124	
<b>MASTER DIE LENGTH</b>	56		65		65		75		75		100		100		120		80	
<b>STANDARD CONTROL</b>	MICROMETER		MICROMETER		MICROMETER		MICROMETER		MICROMETER		MICROMETER		MICROMETER		MICROMETER		ELECTRONIC	
<b>OPTIONAL CONTROL</b>	-		-		-		-		-		-		-		-		ELECTRONIC	
<b>MACHINE DIMENSION (WXDXH) CM</b>	30X22X40		48X30X42		63X45X59		63X45X59		80X44X67		80X44X70		80X44X70		80X44X80		90X85X141	
<b>NET WEIGHT WITH OIL (KG)</b>	27		40		62		68		130		180		185		230		720	
<b>ELECTRIC</b>	N/A		N/A		12/24 VDC 110/220 V 1-P 220/400V 3P		12/24 VDC 110/220V 1-P 220/400V 3P+HN		220V 1-PH 220V 3-PH 400V 3-PH		12/24 VDC 220V 1-PH 220V 3-PH 400V 3-PH		12/24 VDC 220V 1-PH 220V 3-PH 400V 3-PH		12/24 VDC 220V 1-PH 220V 3-PH 400V 3-PH		3-PH	
<b>HOURLY</b>	N/A		N/A		180		240		400		720		720		620		1600	



# SECURE ONLINE ORDERING WITH FREE DELIVERY

All products in this catalogue are available to purchase online at [www.flowfitonline.com](http://www.flowfitonline.com)

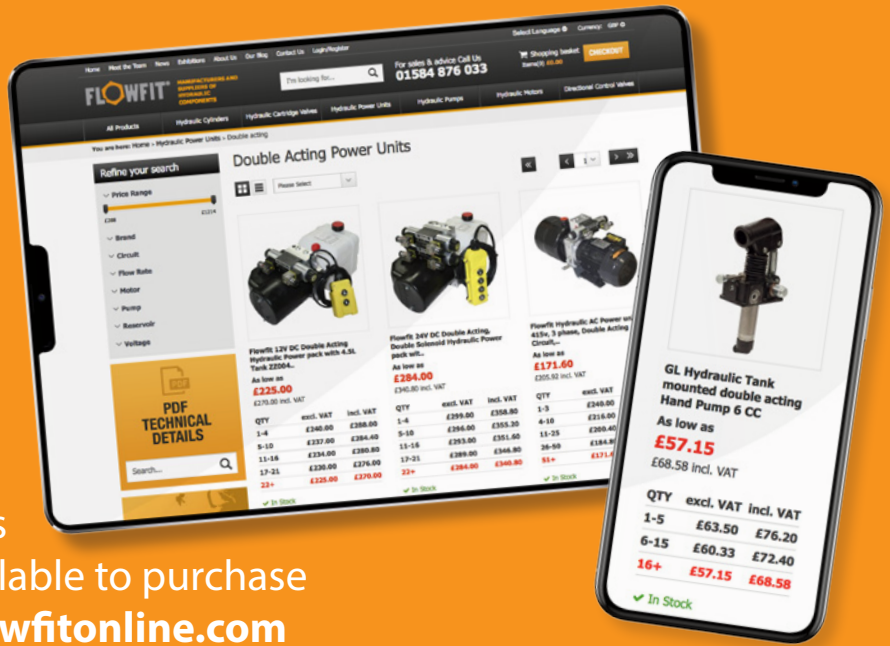

**100%  
SECURE  
SHOPPING**

**HASSLE FREE  
DELIVERY  
DIRECT TO  
YOUR DOOR**

**NO  
QUIBBLE  
GUARANTEE**

**24  
HOUR  
SHOPPING**

**UK  
BASED  
CALL CENTRE**

Selected products and special offers can also be found on our ebay store.



## OVERSEAS CUSTOMERS

All items in this catalogue and at [www.flowfitonline.com](http://www.flowfitonline.com) are available to overseas customers. Please contact us for shipping costs.

Follow us on



## SHOP NOW OPEN 6 DAYS A WEEK



Harrier Fluid Power Ltd T/A Flowfit, Parys Road, Ludlow Business Park, Ludlow, Shropshire SY8 1XY

Telephone: +44 (0)1584 876 033 Fax: +44 (0)1584 876 044

Email: [sales@flowfitonline.com](mailto:sales@flowfitonline.com)



Every effort has been made to ensure that the information in this catalogue is correct. However, we reserve the right to introduce changes without prior notice. This catalogue supersedes all previous catalogues.

