



VNKT series motor adapt the advanced Geroler gear set design with disc distribution flow and high pressure. The unit can be supplied the individual variant in operating multifunction in accordance with requirement of applications.

Characteristic features:

- * Advanced manufacturing devices for the Geroler gear set, which use low pressure of start-up, provide smooth and reliable operation and high efficiency.
- * The output shaft adapts in tapered roller bearings that permit high axial and radial forces. Can offer capacities of high pressure and high torque in the wide of applications.
- * Advanced design in disc distribution flow, which can automatically compensate in operating with high volume efficiency and long life, provide smooth and reliable operation.

Type		VNKT 160	VNKT 200	VNKT 230	VNKT 250	VNKT 315	VNKT 400	VNKT 500	VNKT 630	VNKT 800
Geometric displacement (cm ³ /rev.)		161.1	201.4	232.5	251.8	326.3	410.9	523.6	629.1	801.8
Max. speed (rpm)	cont.	625	625	536	500	380	305	240	196	154
	int.	780	750	643	600	460	365	285	233	185
Max. torque (N•m)	cont.	470	590	670	730	950	1080	1220	1318	1464
	int.	560	710	821	880	1140	1260	1370	1498	1520
	peak	669	838	958	1036	1346.3	1450.3	1643.8	1618.8	1665
Max. output (kW)	cont.	27.7	34.9	34.7	34.5	34.9	31.2	28.8	25.3	22.2
	int.	32	40	40	40	40	35	35	27.5	26.8
Max. pressure drop (MPa)	cont.	20	20	20	20	20	18	16	14	12.5
	int.	24	24	24	24	24	21	18	16	13
	peak	28	28	28	28	28	24	21	19	16
Max. flow (L/min)	cont.	100	125	125	125	125	125	125	125	125
	int.	125	150	150	150	150	150	150	150	150
Max. inlet pressure (MPa)	cont.	21	21	21	21	21	21	21	21	21
	int.	25	25	25	25	25	25	25	25	25
	peak	30	30	30	30	30	30	30	30	30
Weight (kg)		19.5	20	20.4	20.5	21	22	23	24	25

- * Continuous pressure :Max. value of operating motor continuously.
- * Intermittent pressure :Max. value of operating motor in 6 seconds per minute.
- * Peak pressure :Max. value of operating motor in 0.6 second per minute.



VNKT 160 [161.1cm³/rev.]

		Pressure (MPa)						
		4	8	10	12	16	20	24
Flow (L/min)	10	88	176	228	275	361	447	535
		60	59	58	56	54	50	44
	20	89	181	234	277	372	459	557
		121	120	117	114	109	103	95
	40	91	180	235	277	381	471	573
		249	246	243	236	230	223	212
	60	82	178	235	277	381	470	572
		371	367	362	356	349	340	330
	80	78	173	229	276	379	466	567
		492	489	485	478	470	462	447
Max.cont.	100	70	160	218	269	370	455	558
	614	611	606	598	590	582	570	
Max.int.	125	58	148	211	261	359	448	552
	770	764	758	750	741	731	715	

VNKT 200 [201.4cm³/rev.]

		Pressure (MPa)						
		4	8	10	12	16	20	24
Flow (L/min)	10	124	233	289	340	454	560	669
		47	46	45	42	39	37	33
	20	125	239	298	347	468	576	696
		95	94	92	90	87	84	75
	40	120	241	296	352	475	589	716
		195	193	191	187	183	178	167
	60	116	237	295	352	478	589	718
		297	295	292	287	282	276	263
	80	108	231	289	350	474	586	716
		395	393	389	384	377	370	359
Max.cont.	100	99	227	286	344	471	580	712
	493	490	486	482	475	467	460	
Max.int.	125	84	208	276	333	459	566	697
	615	611	607	602	595	588	572	
Max.int.	150	70	194	260	324	447	554	682
	743	740	735	727	717	706	682	

VNKT 250 [251.8cm³/rev.]

		Pressure (MPa)						
		4	8	10	12	16	20	24
Flow (L/min)	10	138	286	355	419	559	689	824
		38	38	37	36	34	32	31
	20	143	296	364	432	580	708	853
		76	75	74	72	70	67	62
	40	139	301	372	440	593	723	884
		156	154	152	149	146	142	134
	60	132	294	372	441	592	727	888
		237	236	233	229	224	219	207
	80	128	283	364	433	587	721	887
		317	316	314	308	303	299	284
Max.cont.	100	126	282	355	427	582	716	879
	396	394	391	387	381	373	359	
Max.int.	125	116	260	340	414	568	703	864
	495	492	488	483	476	469	454	
Max.int.	150	88	242	320	397	552	686	847
	592	589	585	580	572	565	545	

VNKT 315 [326.3cm³/rev.]

		Pressure (MPa)						
		4	8	10	12	16	20	24
Flow (L/min)	10	184	363	453	545	734	891	1062
		30	29	28	27	26	25	23
	20	189	380	472	562	757	917	1109
		60	59	58	56	54	52	50
	40	191	381	484	570	774	954	1149
		121	120	118	115	112	109	104
	60	189	376	493	573	772	962	1154
		183	181	179	175	172	168	158
	80	179	369	479	565	768	954	1153
		244	242	239	236	231	227	217
Max.cont.	100	169	357	467	562	758	942	1143
	305	304	301	298	294	289	276	
Max.int.	125	147	336	447	544	745	920	1127
	380	378	375	371	367	362	349	
Max.int.	150	119	318	432	526	713	894	1097
	458	456	453	449	444	431	425	

Torque (N·m) 552
Speed (rpm) 572

cont.
int.





VNKT 400 [410.9cm³/rev.]

Pressure (MPa)		Max.cont						Max.int
		3	6	9	12	15	18	21
Flow (L/min)	10	176	367	560	715	885	1050	1209
		24	23	22	21	20	19	18
	20	179	370	565	726	899	1071	1236
		49	48	47	44	42	40	38
	40	176	370	567	733	919	1091	1263
		96	95	93	90	87	83	79
	60	174	361	563	729	920	1095	1269
		145	143	139	135	131	127	121
	80	166	353	553	719	912	1084	1263
		193	191	188	184	180	176	170
100	150	339	538	708	896	1067	1252	
	242	240	238	234	228	224	218	
Max.cont.	125	302	300	298	294	289	285	278
Max.int.	150	126	292	508	666	852	1020	1197
		364	362	358	354	350	346	339

VNKT 500 [523.6cm³/rev.]

Pressure (MPa)		Max.cont						Max.int
		3	6	9	12	14	16	18
Flow (L/min)	10	222	451	692	892	1050	1193	1340
		18	18	18	17	16	15	13
	20	231	464	714	918	1070	1220	1377
		37	36	35	34	33	32	30
	40	230	466	727	941	1094	1244	1422
		75	74	73	72	70	68	64
	60	225	457	714	941	1088	1245	1409
		113	112	111	109	107	105	101
	80	213	431	696	927	1076	1244	1401
		151	150	149	147	145	143	138
100	194	420	680	901	1063	1224	1383	
	189	188	187	185	183	181	177	
Max.cont.	125	182	398	641	877	1024	1199	1352
Max.int.	150	147	369	618	853	1004	1167	1325
		284	283	282	280	278	276	272

VNKT 630 [629.1cm³/rev.]

Pressure (MPa)		Max.cont						Max.int
		3	6	9	10.5	12	14	16
Flow (L/min)	10	233	520	795	902	1074	1194	1363
		14	14	13	13	13	11	11
	20	237	554	837	953	1117	1239	1407
		28	27	27	26	26	24	22
	40	239	553	860	987	1171	1308	1483
		62	62	61	60	59	56	54
	60	223	544	863	978	1172	1318	1498
		94	94	92	91	90	86	82
	80	220	537	854	965	1172	1314	1497
		123	122	121	119	118	114	110
100	208	522	832	945	1156	1303	1488	
	156	155	153	152	150	147	142	
Max.cont.	125	201	499	810	931	1137	1292	1472
Max.int.	150	174	492	785	921	1121	1277	1454
		233	232	231	230	227	223	217

VNKT 800 [801.8cm³/rev.]

Pressure (MPa)		Max.cont						Max.int
		3	6	9	10.5	12.5	13	
Flow (L/min)	10	346	677	1003	1159	1365	1390	
		12	12	11	11	11	10	
	20	356	692	1034	1183	1404	1458	
		24	24	24	23	22	18	
	40	365	703	1066	1236	1459	1516	
		50	50	49	48	46	40	
	60	354	703	1060	1237	1464	1520	
		74	73	71	71	68	63	
	80	332	686	1050	1226	1464	1514	
		99	98	98	96	93	86	
100	305	654	1025	1207	1445	1506		
	125	123	123	121	118	110		
Max.cont.	125	280	622	989	1181	1422	1487	
Max.int.	150	247	590	953	1156	1406	1476	
		185	184	183	181	179	172	

Torque (N·m) 1121
Speed (rpm) 227

cont.
int.



VNKT DIMENSIONS AND MOUNTING DATA

Model	L	L1	L2
VNKTW160	127	17	77
VNKTW200	131	21	81
VNKTW250	136	14	86
VNKTW315	142	20	91
VNKTW400	148	27	98
VNKTW500	157	35	106
VNKTW630	169	47	118
VNKTW800	180	58	129

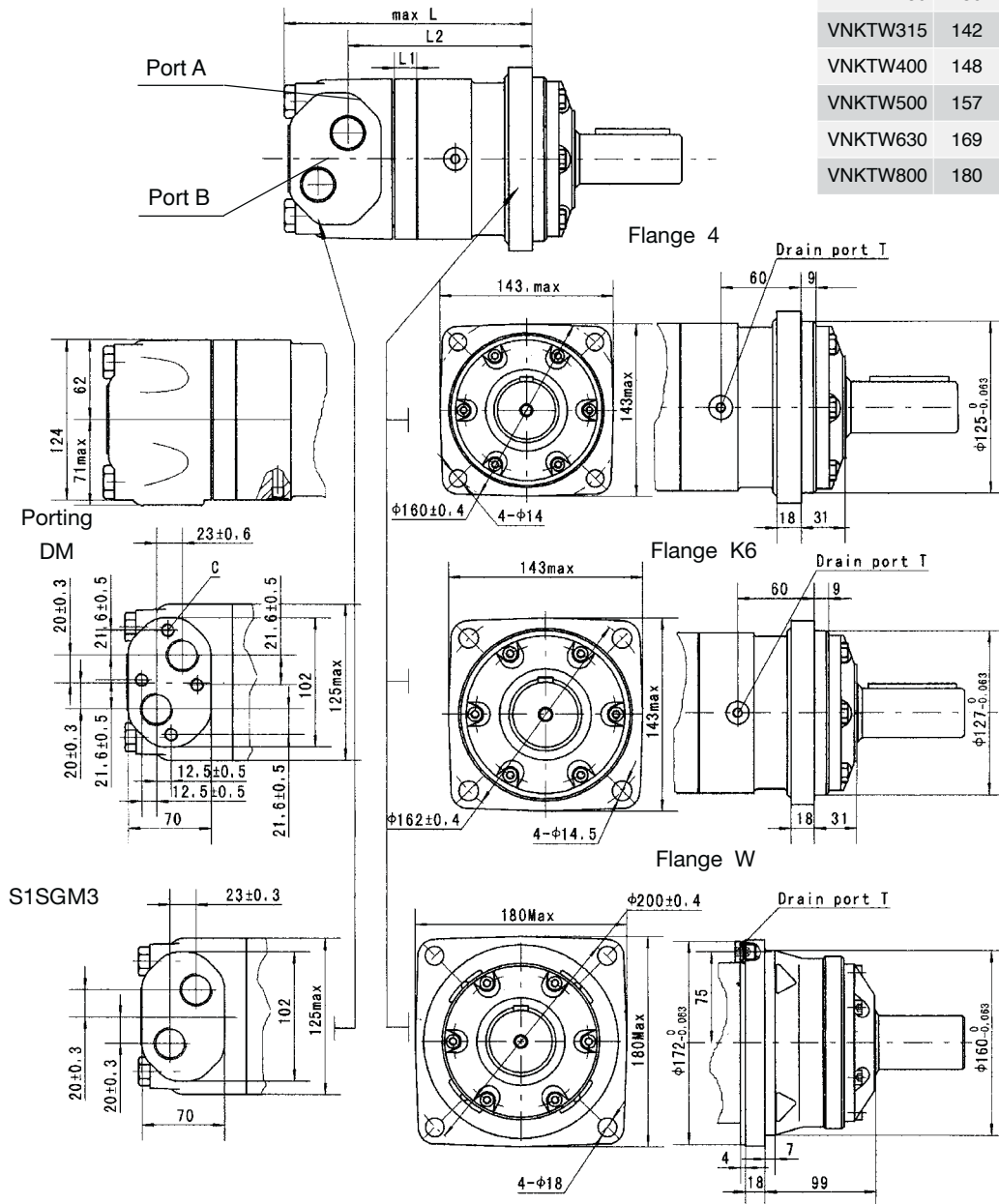

Model	L	L1	L2
VNKT160	193	17	142.5
VNKT200	197	21	146.5
VNKT250	204	14	152.5
VNKT315	210	20	158.5
VNKT400	217	27	165.5
VNKT500	225	35	173.5
VNKT630	237	47	185.5
VNKT800	248	58	196.5

Content	Code					
Mounting	D (depth)	M (depth)	S (depth)	G (depth)	M3 (depth)	S1 (depth)
P(A,B)	G3/4 (18)	M27 x 2 (18)	1-1/16-12UN (18)	G3/4 (18)	M27 x 2 (18)	1-1/16-12UN (18)
T	G1/4 (12)	M14 x 1.5 (12)	9/16-18UNF (12)	G1/4 (12)	M14 x 1.5 (12)	7/16-20UNF (12)
C	4-M10(10)	4-M10(10)	--	--	--	--

Note:1)The thickness of the stator and rotor for disp. from 160 to 200 is the dimension of L1 adding on 3mm.
 2)The thickness of the stator and rotor for disp. from 250 to 800 is the dimension of L1 adding on 7mm.

