



VNKR series motor adapt the advanced Gerolor gear set design with shaft distribution flow, which can automatically compensate in operating with high pressure, provide reliable and smooth operation, high efficiency and long life.

Characteristic features:

- Advanced manufacturing devices for the Gerolor gear set, which use low pressure of start-up, provide smooth, reliable operation and high efficiency.
- Shaft seal can bear high pressure of back and the motor can be used in parallel or in series. Special design in the driver-linker and prolong operating life
- Special design for distribution system can meet the requirement of low noise of unit.
- Compact volume and easy installation.
- HPS**, shaft seal can bear high pressure (150bar) of motor of which can be used in parallel or in series. Advanced construction design, high power and low weight.
- The output shaft runs in **needle bearing** capable of absorbing static and dynamic axial and radial loads.
- Supporting +300 hours of salt spray.

Main Specification

Technical data for VNKR with 25 and 1 in and 1 in splined and 28.56 tapered shaft

Type	VNKR VNKRH 36	VNKR VNKRH 50	VNKR VNKRH 80	VNKR VNKRH 100	VNKR VNKRH 125	VNKR VNKRH 160	VNKR VNKRH 200	VNKR VNKRH 250	VNKR VNKRH 315	VNKR VNKRH 400	
Geometric displacement (cm ³ /rev.)	36	51,7	81,5	102	127,2	157,2	194,5	253,3	317,5	381,4	
Max. speed (rpm)	cont.	1085	960	750	600	475	378	310	240	190	155
	int.	1220	1150	940	750	600	475	385	300	240	190
Max. torque (N•m)	cont.	72	100	195	240	300	360	360	390	390	365
	int.	83	126	220	280	340	430	440	490	535	495
	peak	105	165	270	320	370	460	560	640	650	680
Max. output (kW)	cont.	8,5	9,5	12,5	13,0	12,5	12,5	10,0	7,0	6,0	5,0
	int.	9,8	11,2	15,0	15,0	14,5	14,0	13,0	9,5	9,0	8,0
Max. pressure drop (MPa)	cont.	14,0	14	17,5	17,5	17,5	16,5	13	11	9	7
	int.	16,5	17,5	20	20	20	20	17,5	15	13	10
	peak	22,5	22,5	22,5	22,5	22,5	22,5	22,5	20	17,5	15
Max. flow (L/min)	cont.	40	50	60	60	60	60	60	60	60	60
	int.	45	60	75	75	75	75	75	75	75	75
Weight (kg)	6,5	6,7	6,9	7	7,3	7,6	8	8,5	9	9,5	

- Continuous pressure:Max. value of operating motor continuously.
- Intermittent pressure:Max. value of operating motor in 6 seconds per minute
- Peak pressure:Max. value of operating motor in 0.6 second per minute.



Main Specification

Technical data for VNKR with 31.75 and 32 shaft

Type		VNKR VNKRH 36	VNKR VNKRH 50	VNKR VNKRH 80	VNKR VNKRH 100	VNKR VNKRH 125	VNKR VNKRH 160	VNKR VNKRH 200	VNKR VNKRH 250	VNKR VNKRH 315	VNKR VNKRH 400
Geometric displacement (cm ³ /rev.)		36	51,7	81,5	10,2	127,2	157,2	194,5	253,3	317,5	381,4
Max. speed (rpm)	cont.	1250	960	750	600	475	378	310	240	190	155
	int.	1520	1150	940	750	600	475	385	300	240	190
Max. torque (N•m)	cont.	72	100	195	240	300	380	450	540	550	580
	int.	83	126	220	280	340	430	500	610	690	690
	peak	105	165	270	320	370	460	560	710	840	830
Max. output (kW)	cont.	8,5	9,5	12,5	13,0	12,5	12,5	11,0	10,0	9,0	7,5
	int.	9,8	11,2	15,0	15,0	14,5	14,0	13,0	12,0	10,0	9,0
Max. pressure drop (MPa)	cont.	14,0	14	17,5	17,5	17,5	17,5	17,5	17,5	13,5	11,5
	int.	16,5	17,5	20	20	20	20	20	20	17,5	15
	peak	22,5	22,5	22,5	22,5	22,5	22,5	22,5	22,5	21	17,5
Max. flow (L/min)	cont.	45	50	60	60	60	60	60	60	60	60
	int.	55	60	75	75	75	75	75	75	75	75
Weight (kg)		6,5	6,7	6,9	7	7,3	7,6	8	8,5	9	9,5

- Continuous pressure:Max. value of operating motor continuously.
- Intermittent pressure:Max. value of operating motor in 6 seconds per minute
- Peak pressure:Max. value of operating motor in 0.6 second per minute.



VNKR 36 [36cm³/rev.]

		Pressure (MPa)													
		2	3	5	7	9	10	12.5	14.0	16.5	Max.cont.	Max.int.			
Flow (L/min)	4	105	100	92	80	71	58								
	8	208	200	188	175	158	149	134	120	108					
	15	403	392	380	365	348	326	318	302	274					
	20	540	531	518	500	483	462	450	435	412					
	30	810	798	780	763	742	722	705	694	668					
	Max.cont.	40	1092	1080	1069	1056	1042	1028	1011	984	957				
	Max.int.	45	1230	1215	1194	1170	1150	1128	1100	1070	1020				

VNKR 50 [51.7cm³/rev.]

		Pressure (MPa)													
		5	7	9	10	12	14	16	17.5	Max.cont.	Max.int.				
Flow (L/min)	5	93	84	76	73	69	46								
	10	186	178	166	162	153	136	118	97						
	15	283	277	269	261	250	230	211	185						
	20	377	375	365	361	346	330	302	270						
	30	576	569	561	554	542	531	500	465						
	40	760	758	753	750	738	724	700	670						
	45	856	853	849	845	835	815	796	770						
	Max.cont.	50	950	940	925	906	880	852	832	801					
	Max.int.	60	1138	1124	1100	1075	1056	1028	1006	970					

VNKR 80 [81.5cm³/rev.]

		Pressure (MPa)													
		5	7	9	10	12	14	16	17.5	20	Max.cont.	Max.int.			
Flow (L/min)	5	59	56	50	44	38									
	10	118	113	106	97	86	79	56							
	20	238	234	227	216	203	190	178	154	135					
	30	360	352	340	332	316	302	290	274	250					
	40	480	470	458	445	430	418	403	388	359					
	50	604	595	582	570	556	540	521	504	487					
	Max.cont.	60	726	715	704	692	678	663	647	622	594				
	70	845	834	820	802	789	767	754	730	705					
	Max.int.	75	910	895	881	867	852	830	806	787	756				

VNKR 100 [102cm³/rev.]

		Pressure (MPa)													
		5	7	9	10	12	14	16	17.5	20	Max.cont.	Max.int.			
Flow (L/min)	5	45	42	38	34	27									
	10	93	90	86	81	74	57	42							
	20	189	185	180	173	165	158	150	139	118					
	30	286	281	275	266	257	246	237	225	207					
	40	385	378	365	355	345	332	320	314	297					
	50	482	477	470	460	448	435	420	405	389					
	Max.cont.	60	580	572	560	548	535	523	510	500	478				
	70	678	670	660	648	638	626	615	606	580					
	Max.int.	75	728	720	710	695	681	667	650	634	618				

Torque (N·m) 135
Speed (rpm) 830

cont.
int.



VNKR 125 [127.2cm³/rev.]

		Pressure (MPa)										Max.cont		Max.int			
		5	7	9	10	12	14	16	17.5	20							
Flow (L/min)	5	76	110	145	167	189											
	10	84	118	155	176	202	228	253									
	20	82	117	153	174	200	230	259	294	332							
	30	79	116	151	171	198	228	257	292	329							
	40	72	114	148	168	196	226	256	290	327							
	50	62	105	143	165	195	223	254	287	323							
	Max.cont.	60	52	98	136	160	191	220	250	282	319						
		70	41	90	130	156	187	215	242	278	313						
	Max.int.	75	32	79	126	148	180	208	234	262	300						
			586	583	578	570	560	546	532	520	480						

VNKR 160 [157.2cm³/rev.]

		Pressure (MPa)										Max.cont		Max.int			
		5	7	9	10	12	14	16	17.5	20							
Flow (L/min)	5	104	146	190	210	245											
	10	107	150	195	216	250	290	335									
	20	102	151	198	220	257	298	342	370	420							
	30	97	146	190	217	256	295	340	368	416							
	40	89	140	185	210	252	290	335	363	412							
	50	72	128	179	202	244	284	327	358	409							
	Max.cont.	60	60	116	170	198	240	279	321	352	400						
		70	49	107	164	193	233	271	309	344	390						
	Max.int.	75	36	98	152	185	226	265	300	334	379						
			472	463	450	441	431	420	405	389	365						

VNKR 200 [194.5cm³/rev.]

		Pressure (MPa)										Max.cont		Max.int			
		5	7	9	10	12	14	16	17.5	20							
Flow (L/min)	5	132	181	238	262	310											
	10	135	186	240	264	315	356	403									
	20	131	183	238	260	314	358	404	438	498							
	30	126	178	233	254	311	355	402	431	486							
	40	112	169	228	250	307	352	400	426	477							
	50	95	156	221	246	300	350	398	421	470							
	Max.cont.	60	78	145	213	238	289	342	386	412	459						
		70	67	135	206	228	277	336	375	408	453						
	Max.int.	75	58	125	197	220	270	321	360	398	442						
			382	379	373	362	350	337	322	312	278						

VNKR 250 [253.5cm³/rev.]

		Pressure (MPa)										Max.cont		Max.int			
		5	7	9	10	12	14	16	17.5	20							
Flow (L/min)	5	175	243	304	342	407											
	10	178	246	310	344	409	465	525									
	20	175	244	308	340	408	463	520	558	636							
	30	162	235	304	332	400	455	516	550	621							
	40	143	223	300	329	396	447	512	546	617							
	50	124	208	289	323	384	440	503	535	600							
	Max.cont.	60	103	192	280	314	371	426	489	514	578						
		70	88	178	264	301	356	418	479	498	560						
	Max.int.	75	62	165	256	288	347	412	474	486	542						
			294	291	287	283	274	263	249	236	211						

Torque (N·m) 256
Speed (rpm) 287

cont.
int.





HYDRAULIC MOTORS

PERFORMANCE DATA

VNKR 315 [317.5cm³/rev.]

Pressure (MPa)

		Max.cont							Max.int		
		5	7	9	10	12	14	16	17.5		
Flow (L/min)	5	215	302								
		13	11								
	10	218	305	383	422	488	551	622			
		28	27	25	24	21	18	13			
	20	215	303	380	418	485	549	620	660		
		60	59	57	55	52	49	45	42		
	30	204	296	375	413	480	542	613	654		
		91	89	86	84	81	78	72	67		
	40	196	287	368	410	477	539	609	650		
		122	120	117	112	106	100	94	85		
Max.cont.	50	176	270	356	393	461	526	597	645		
		154	151	147	140	131	120	109	100		
	60	162	246	339	374	446	511	586	628		
		185	182	177	172	163	152	140	134		
	70	143	235	324	358	430	493	562	614		
Max.int.		217	213	208	201	190	178	166	158		
	75	125	212	303	339	417	481	543	582		
		232	228	222	216	208	200	183	171		

Torque (N·m) 481
Speed (rpm) 200

VNKR 400 [381.4cm³/rev.]

Pressure (MPa)

		Max.cont							Max.int		
		3	4.5	5.5	6.5	8	10	12.5	14		
Flow (L/min)	5	153	232								
		12	10								
	10	157	236	284	337	406	497	612	668		
		24	23	22	21	19	17	15	12		
	20	150	232	280	332	401	490	606	660		
		49	48	47	46	44	41	38	32		
	30	142	215	274	327	398	483	603	652		
		76	75	74	73	71	67	63	50		
	40	126	212	268	320	393	477	593	635		
		103	101	99	97	95	92	88	70		
Max.cont.	50	105	187	242	302	376	455	583	608		
		128	126	124	121	118	115	111	96		
	60	90	167	229	281	362	444	566	600		
		154	152	150	148	145	138	130	121		
	70	90	149	200	258	341	425	546	580		
Max.int.		180	179	178	176	173	168	160	148		
	75	56	125	182	241	320	408	524	565		
		195	194	193	191	189	185	178	170		

cont.
int.

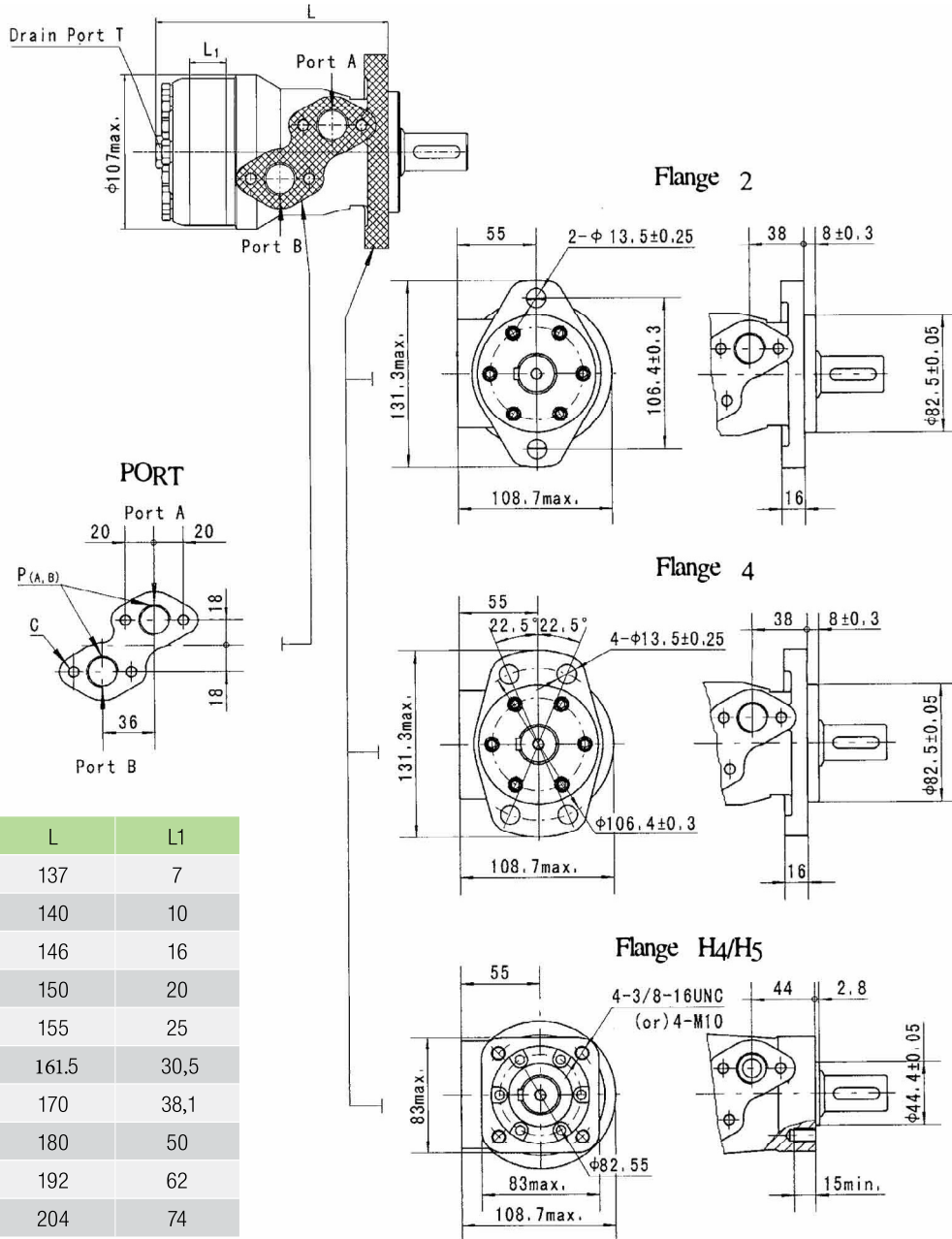

Model	L	L1
VNKR36	137	7
VNKR50	140	10
VNKR80	146	16
VNKR100	150	20
VNKR125	155	25
VNKR160	161.5	30,5
VNKR200	170	38,1
VNKR250	180	50
VNKR315	192	62
VNKR400	204	74

Code	D (depth)	M (depth)	S (depth)	P (depth)	R (depth)
P(A,B)	G1/2 (15)	M22 x 1.5 (15)	7/8-14 O-ring (17)	1/2-14NPTF (15)	PT(RC)1/2 (15)
C	4-M8 (13)	4-M8 (13)	4-5/16-18UNC(13)	4-5/16-18UNC(13)	4-M8 (13)
T	G1/4 (12)	M14 x 1.5 (12)	7/16-20UNF (12)	7/16-20UNF (12)	PT(RC)1/4 (9.7)



MOUNTING

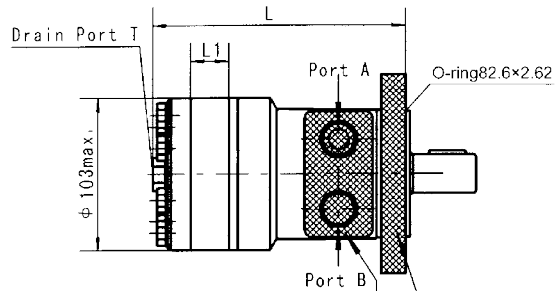

PORT: G S P R M1 M2 M3

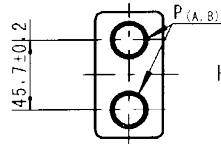

PORT: B4 B5

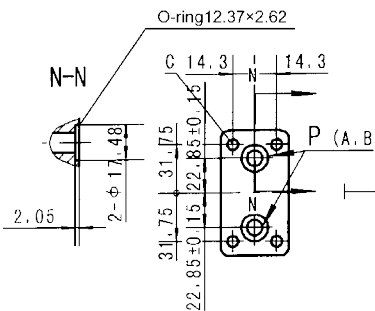

Flange H2

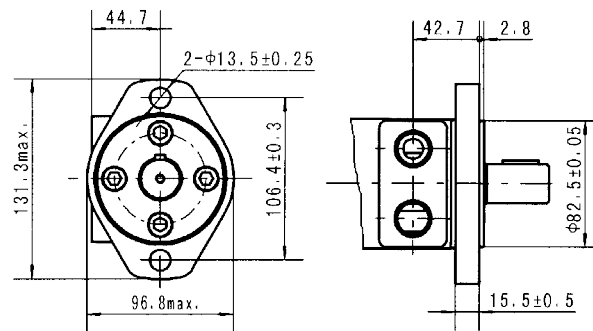

Flange H6

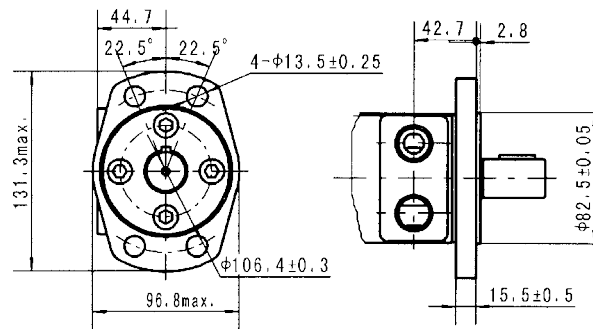

Flange H4/H5

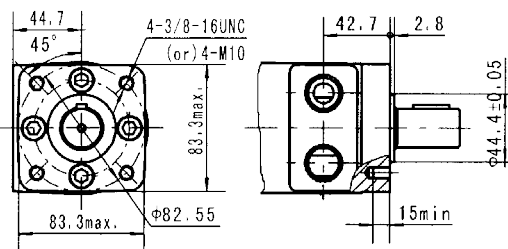

Model	L	L1
VNKRH36	141	7
VNKRH50	144	10
VNKRH80	150	16
VNKRH100	154	20
VNKRH125	159	25
VNKRH160	165.5	30.5
VNKRH200	174	38.1
VNKRH250	184	50
VNKRH315	196	62
VNKRH400	208	74

Code	G (depth)	S (depth)	P (depth)	R (depth)	M1 (depth)	M2 (depth)	M3 (depth)	B4 (depth)	B5 (depth)
Mounting									
P(A,B)	G1/2 (15)	7/8-14 O-ring (17)	1/2-14NPTF (15)	PT(RC)1/2 (15)	M18 x 1.5 (15)	M20 x 1.5 (15)	M22 x 1.5 (15)	ø10	ø10
C	G1/4 (12)	7/16-20UNF (12)	7/16-20UNF (12)	PT(RC)1/4 (9.7)	M10 x 1 (12)	M10 x 1 (12)	M10 x 1 (12)	7/16-20UNF(12)	G1/4(12)
T	-	-	-	-	-	-	-	4-5/16-18UNC(13)	4-M8(13)

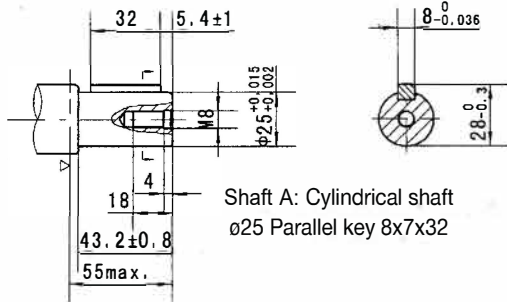

Shaft A: Cylindrical shaft
ø25 Parallel key 8x7x32

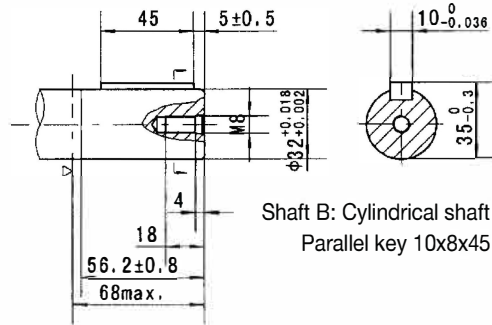

Shaft B: Cylindrical shaft ø32
Parallel key 10x8x45

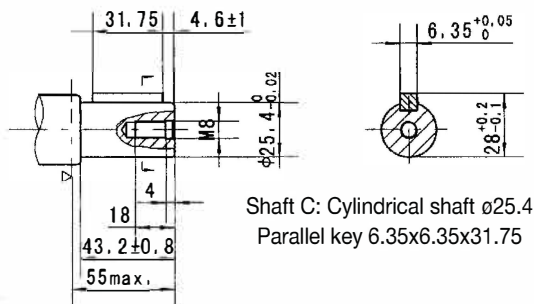

Shaft C: Cylindrical shaft ø25.4
Parallel key 6.35x6.35x31.75

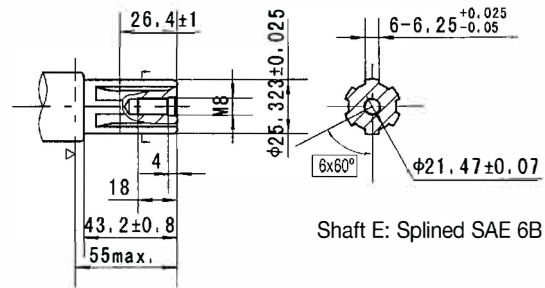

Shaft E: Splined SAE 6B

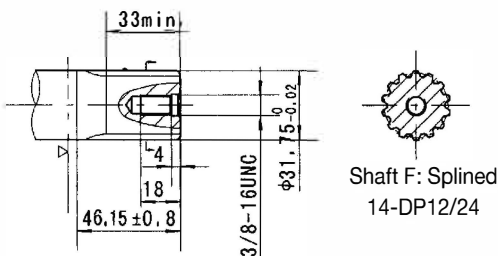

Shaft F: Splined
14-DP12/24

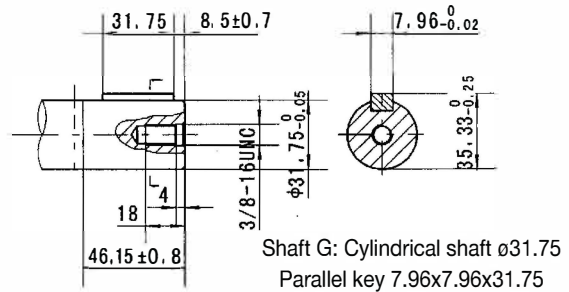

Shaft G: Cylindrical shaft ø31.75
Parallel key 7.96x7.96x31.75

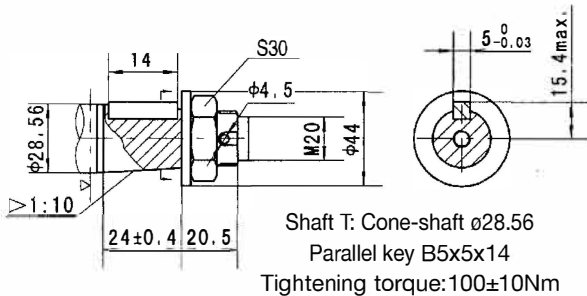

Shaft T: Cone-shaft ø28.56
Parallel key B5x5x14
Tightening torque: 100±10Nm

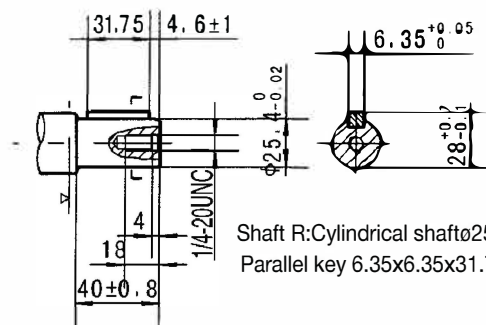

Shaft R: Cylindrical shaft ø25.4
Parallel key 6.35x6.35x31.75

Motor Mounting Surface →

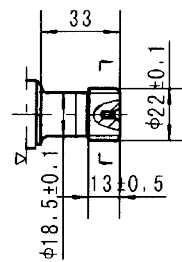
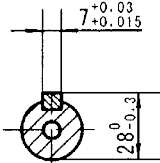
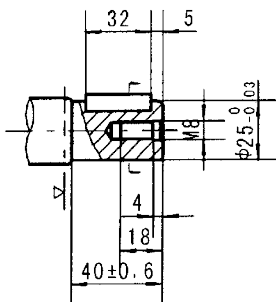
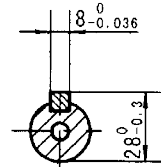
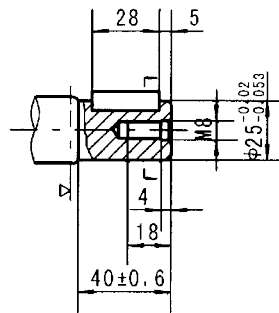
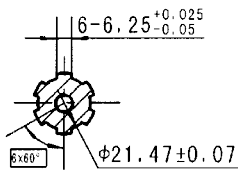
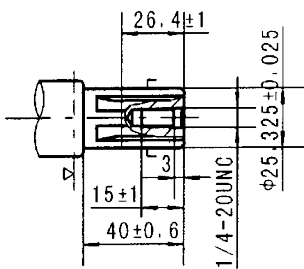
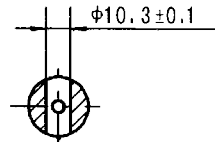
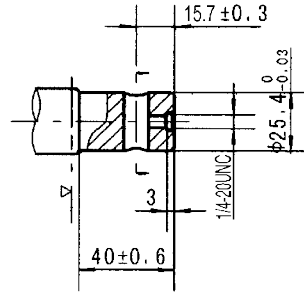
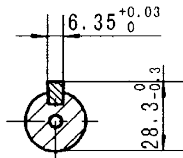
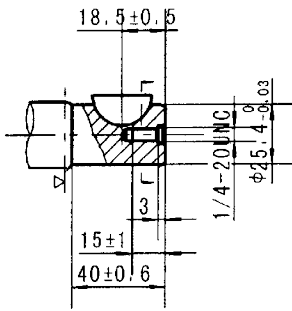

Motor Mounting Surface →



VNKRH SHAFT EXTENSIONS DIMENSIONS DATA

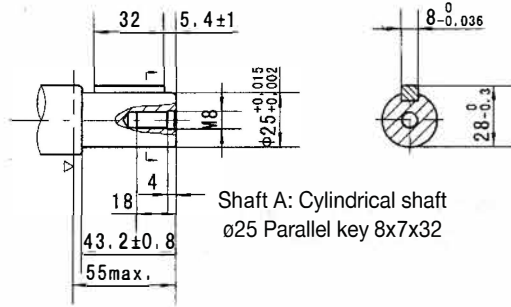

Shaft A: Cylindrical shaft ø25 Parallel key 8x7x32

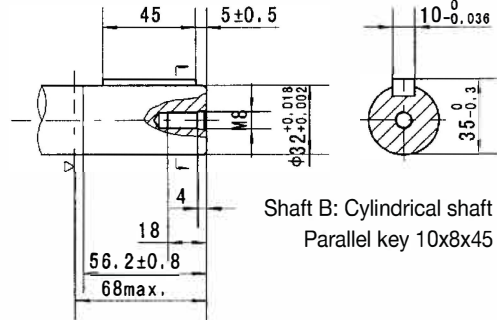

Shaft B: Cylindrical shaft ø32 Parallel key 10x8x45

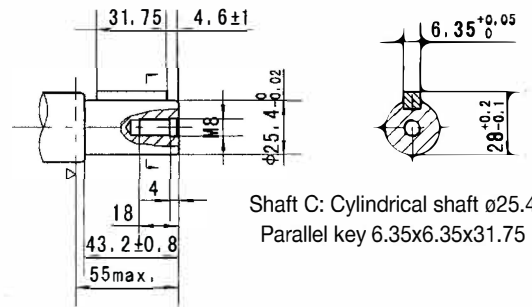

Shaft C: Cylindrical shaft ø25.4 Parallel key 6.35x6.35x31.75

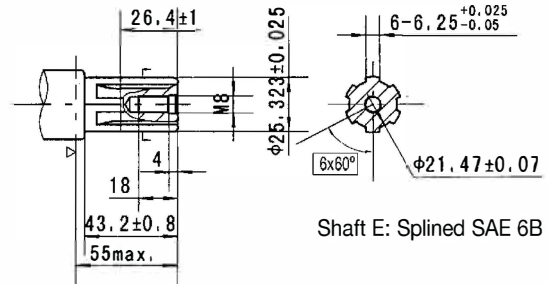

Shaft E: Splined SAE 6B

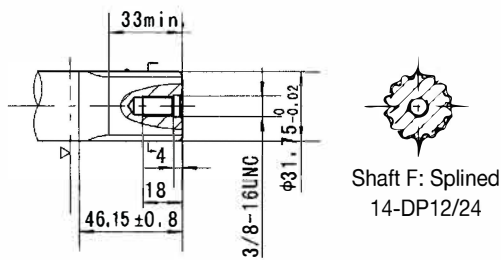

Shaft F: Splined 14-DP12/24

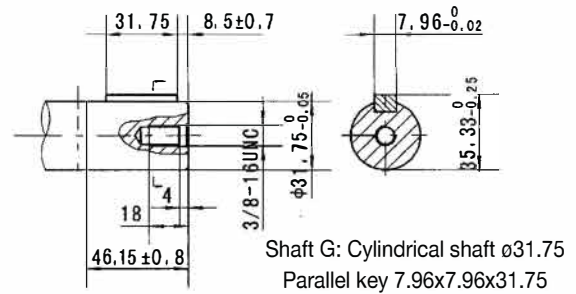

Shaft G: Cylindrical shaft ø31.75 Parallel key 7.96x7.96x31.75

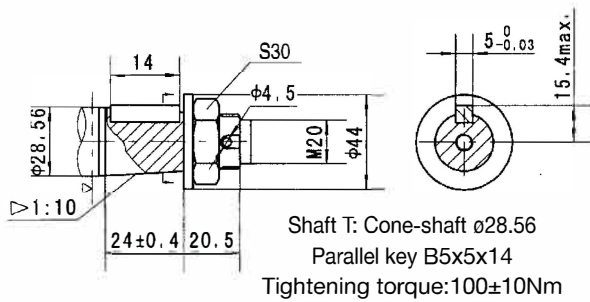

Shaft T: Cone-shaft ø28.56 Parallel key B5x5x14 Tightening torque: 100±10Nm

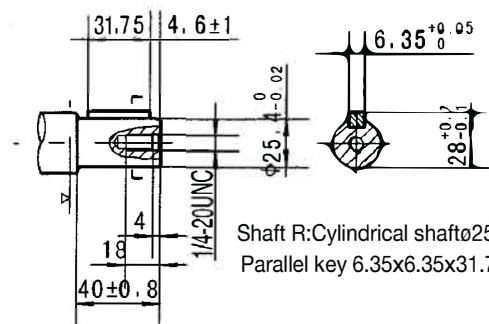

Shaft R: Cylindrical shaft ø25.4 Parallel key 6.35x6.35x31.75

Motor Mounting Surface →



Permissible shaft seal pressure

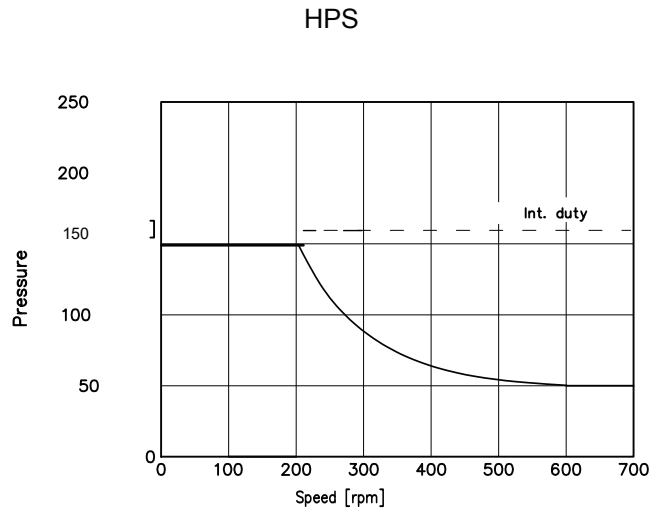
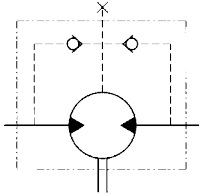

Vincke are made as standard with HPS seal version.

In applications without drain line, output shaft seal exceeds a bit of the pressure in the return line.
When applications use the drain line, the pressure of output shaft seal equals the pressure in drain line.

Direction of shaft rotation : Standard

When facing shaft end of motor, shaft to rotate:
Clockwise when port "A" is pressurized.
Counter-clockwise when port "B" is pressurized.

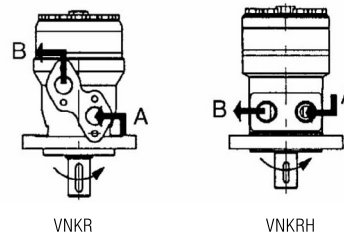

Status of the shaft's radial force with needle bearing

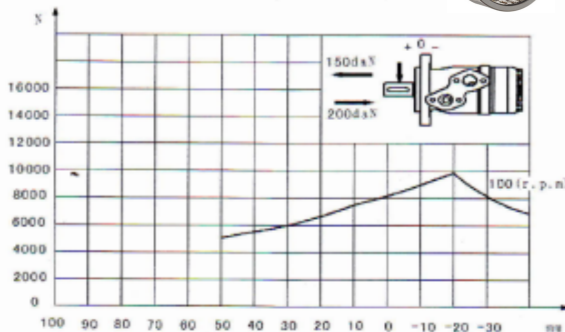

$$F_r = \frac{800 \cdot 25000}{n \cdot 95 + L} \text{ daN}$$

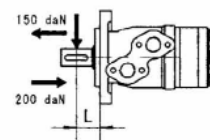

F_r =Radial Force (daN)
 L =Distance (mm)
 n =Speed (rpm)
Rhomb-flange $L=30\text{mm}$
Square-flange $L=24\text{mm}$

The output Shaft on VNKP-N series is supplied with needle bearing and the recessed mounting allow a higher permissible radial load in comparison with VNK series motors. The curves apply to a B10 needle roller bearing life of 2000 hours.

Relationship between output shaft bearing load and multiplication coefficient

Rotating speed	50	100	200	300	400	500	600	700	800
coefficient	1.23	1	0.81	0.72	0.66	0.62	0.58	0.56	0.54



	1	2	3	4	5	6	7	8
Pos.1	2	3	4	5	6	7	8	
Code	Disp.	Flange	Output Shaft	Ports and Drain Port	Rotation Direction	Paint	Unusually Function	
VNKR								
	36	A	Shaft 025.4, parallel Key 8x7x32	G1/2 Manifold Mount 4-M8, G1/4		No paint	Standard	
	50	C	Shaft 025.4, parallel Key 6.35x6.35x31.75	D		00	N	HPS-heavy shaft loads
	80	E	Shaft 025.4, splined tooth SAE 6B	M		Omit	O	No case drain
	100	R	Short shaft 025.4, parallel key 6.35x6.35x31.75	S		B	F	Free Running
	125	B	Shaft 032, parallel Key 10x8x45	P		Black	LS	Low Speed
	160	H4	4-3/8-16 Square-flange, pilot 044.4x2.8	R		Silver grey	SK	Speed sensor
	200	F	Shaft 031.75, splined tooth 14-DP12/24					
	250	H5	4-M10 Square-flange, pilot 044.4x2.8					
	315	FD	Long shaft 031.75, splined tooth 14-DP12/24					
	400	G	Shaft 031.75, parallel Key 7.96x7.96x31.75 Cone-B5x5x14					
		T	Shaft 028.56, parallel Key B5x5x14					

	1	2	3	4	5	6	7	8
Pos.1	2	3	4	5	6	7	8	
Code	Disp.	Flange	Output Shaft	Ports and Drain Port	Rotation Direction	Paint	Unusually Function	
VNKRH								
	36	K	Shaft 025.4, Woodruff Key 025.4x6.35	G		No paint	Standard	
	50	S	Sub-shaft 025.4, splined tooth SAE 6B	S		Blue	N	HPS-heavy shaft loads
	80	A	Shaft 025.4, parallel key 8x7x32	P		Omit	O	No case drain
	100	H2	2-0/13.5 Rhomb-flange, pilot 082.5x2.8	R		Black	F	Free Running
	125	H6	4-0/13.5 Rhomb-flange, pilot 082.5x2.8	T		Silver grey	LS	Low Speed
	160	H4	4-3/8-16 Square-flange, pilot 044.4x2.8	R			SK	Speed sensor
	200	H5	4-M10 Square-flange, pilot 044.4x2.8	B4				
	315	T2	Cone shaft 025.4, woodruff key 025.4x6.35	B5				
	400	P	Shaft 025, parallel Key 8x7x28 Shaft 025, parallel Key 7x7x32	M1				
		J		M2				
				M3				

