

HYDRAULIC MOTORS EPMV

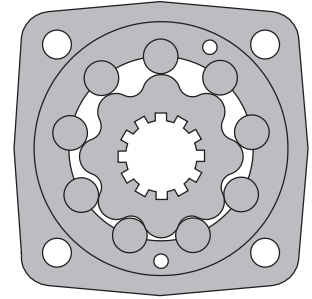

APPLICATION

- » Conveyors;
- » Metal working machines;
- » Machines for agriculture;
- » Road building machines;
- » Mining machinery;
- » Food industries;
- » Special vehicles;
- » Plastic and rubber machinery etc.



CONTENTS

Specification data	98
Function diagrams	99 ÷ 101
Permissible shaft loads	101
Dimensions and mounting	102
Dimensions and mounting- EPMVS	102 ÷ 104
Internal Spline data	104
Tacho connection	104
Shaft extensions	105
Order code	105

OPTIONS

- » Model- Disc valve, geroler;
- » Flange and wheel mount;
- » Short motor;
- » Tacho connection;
- » Side ports
- » Shafts- straight, splined and tapered;
- » Metric and BSPP ports;
- » Other special features.

GENERAL

Displacement, [cm ³ /rev.]	314,5 ÷ 801,8
Max. Speed, [RPM]	510 ÷ 250
Max. Torque, [daNm]	92 ÷ 188
Max. Output, [kW]	42,5 ÷ 53,5
Max. Pressure Drop, [bar]	200 ÷ 160
Max. Oil Flow, [l/min]	160 ÷ 200
Min. Speed, [RPM]	10 ÷ 5
Permissible Shaft Loads, [daN]	P _{rad} =2800; P _σ =1500
Pressure fluid	Mineral based- HLP(DIN 51524) or HM(ISO 6743/4)
Temperature range, [°C]	-30 ÷ 90
Optimal Viscosity range, [mm ² /s]	20 ÷ 75
Filtration	ISO code 20/16 (Min. recommended fluid filtration of 25 micron)

Oil flow in drain line

Pressure drop (bar)	Viscosity (mm ² /s)	Oil flow in drain line (l/min)
140	20	3
	35	2
210	20	6
	35	4

Pressure Losses

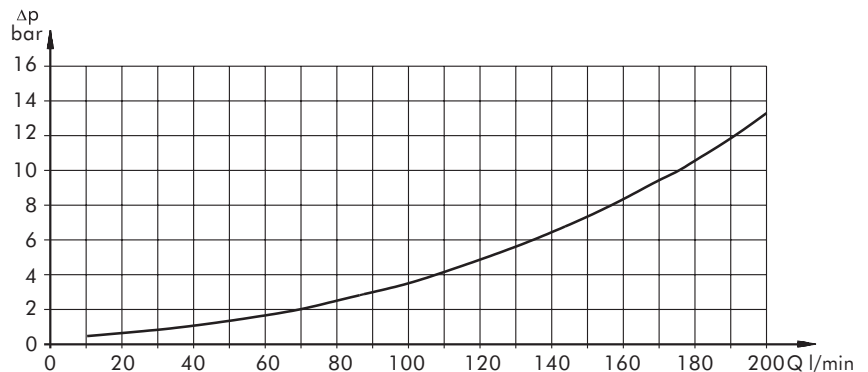

SPECIFICATION DATA

Type		EPMV 315	EPMV 400	EPMV 500	EPMV 630	EPMV 800
Displacement [cm ³ /rev.]		314,5	400,9	499,6	629,1	801,8
Max. Speed, [RPM]	cont.	510	500	400	315	250
	Int.*	630	600	480	380	300
Max. Torque [daNm]	cont.	92	118	146	166	188
	Int.*	111	141	176	194	211
	peak**	129	164	205	221	247
Max. Output [kW]	cont.	42,5	53,5	53,5	48	42,5
	int.*	51	64	64	56	48
Max. Pressure Drop [bar]	cont.	200	200	200	180	160
	Int.*	240	240	240	210	180
	peak**	280	280	280	240	210
Max. Oil Flow [l/min]	cont.	160	200	200	200	200
	Int.*	200	240	240	240	240
Max. Inlet Pressure [bar]	cont.	210	210	210	210	210
	Int.*	250	250	250	250	250
	peak**	300	300	300	300	300
Max. Return Pressure without Drain Line or Max. Pressure in Drain Line , [bar]	cont. 0-100 RPM	60	60	60	60	60
	cont. 100-300 RPM	30	30	30	30	30
	cont. >300 RPM	20	20	20	20	20
	Int.* 0-max. RPM	75	75	75	75	75
Max. Return Pressure with Drain Line [bar]	cont.	140	140	140	140	140
	Int.*	175	175	175	175	175
	peak**	210	210	210	210	210
Max. Starting Pressure with Unloaded Shaft, [bar]		8	8	8	8	8
Min. Starting Torque [daNm]	at max. press. drop cont.	71	91	113	133	151
	at max. press. drop Int.*	85	109	136	155	170
Min. Speed***, [RPM]		10	9	8	6	5
Weight, [kg]	EPMV	31,8	32,6	33,5	34,9	36,5
	EPMVW	32,4	33,2	34,1	35,5	37,1
	EPMVS	22,7	23,5	24,4	25,6	27,7

* Intermittent operation: the permissible values may occur for max. 10% of every minute.

** Peak load: the permissible values may occur for max. 1% of every minute.

*** For speeds of 5 RPM lower than given, consult factory or your regional manager.

- 1) Intermittent speed and intermittent pressure must not occur simultaneously.
- 2) Recommended filtration is per ISO cleanliness code 20/16. A nominal filtration of 25 micron or better.
- 3) Recommend using a premium quality, anti-wear type mineral based hydraulic oil, HLP(DIN51524) or HM(ISO6743/4).
If using synthetic fluids consult the factory for alternative seal materials.
- 4) Recommended minimum oil viscosity 13 mm²/s at 50°C.
- 5) Recommended maximum system operating temperature is 82°C.
- 6) To assure optimum motor life fill with fluid prior to loading and run at moderate load and speed for 10-15 minutes.

FUNCTION DIAGRAMS

EPMV 315

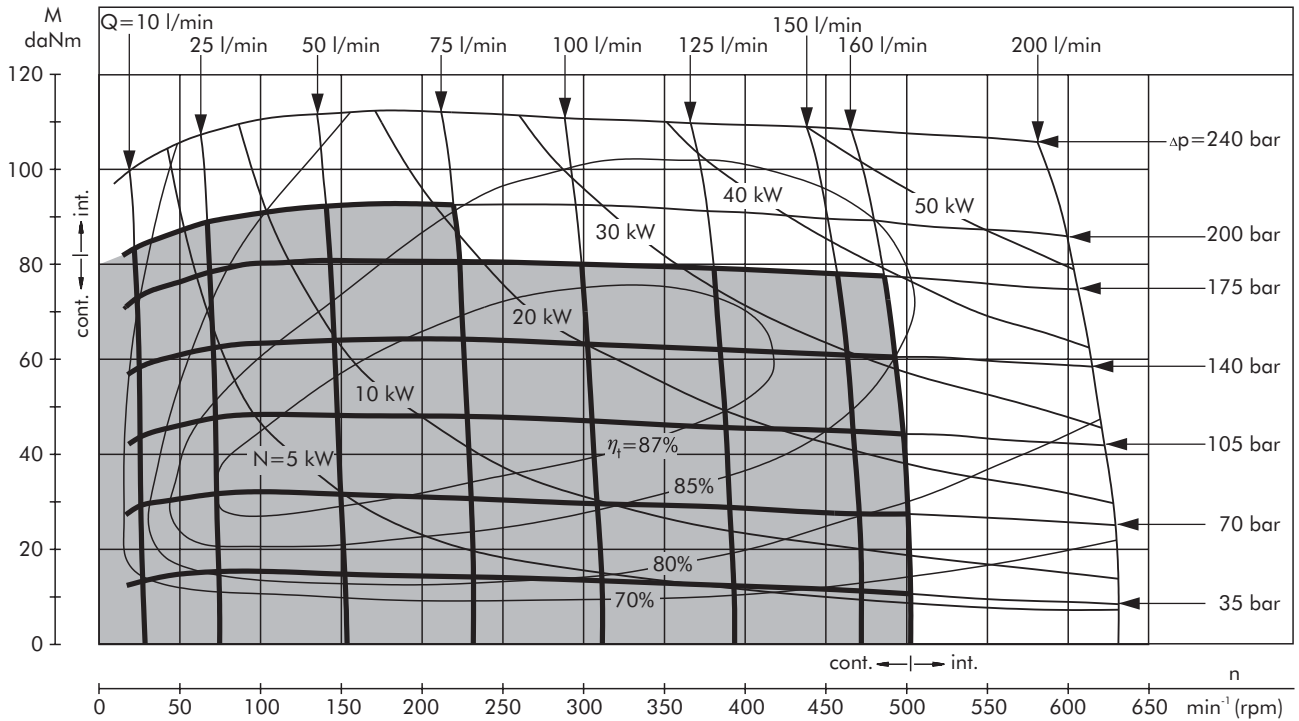

EPMV 400

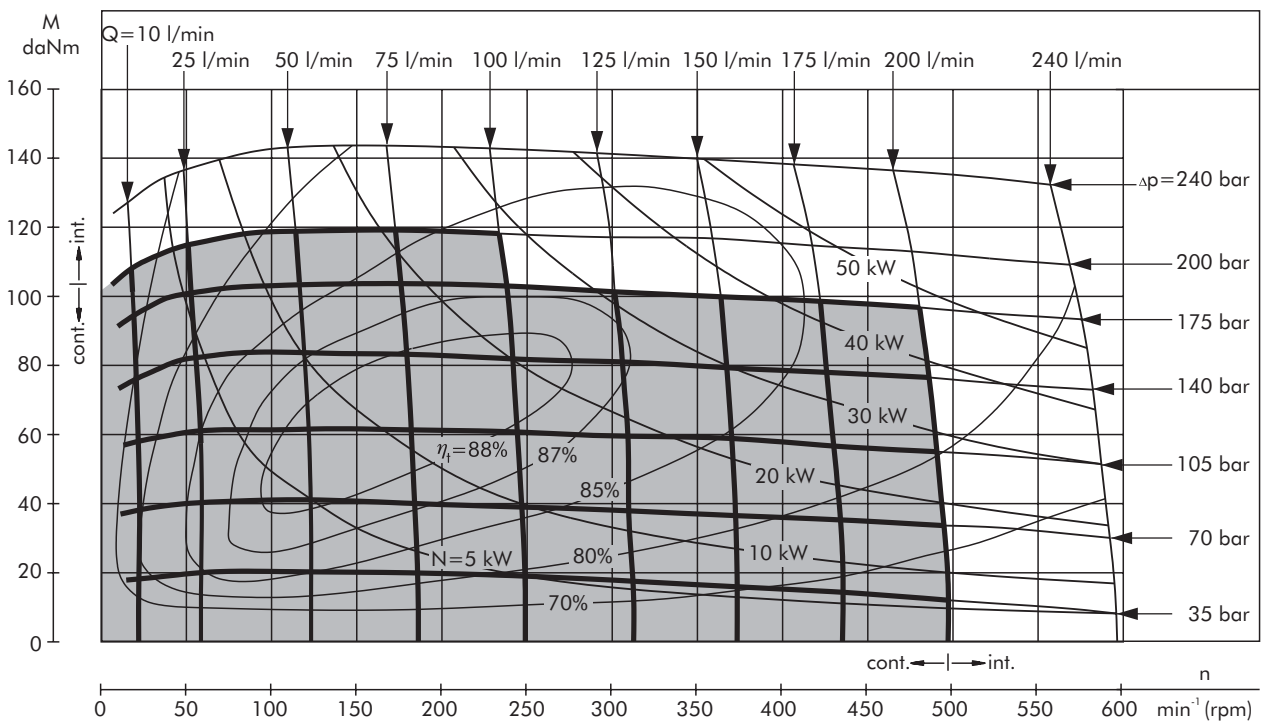

The function diagrams data was collected at back pressure 5 ÷ 10 bar and oil with viscosity of 32 mm²/s at 50° C.

FUNCTION DIAGRAMS

EPMV 500

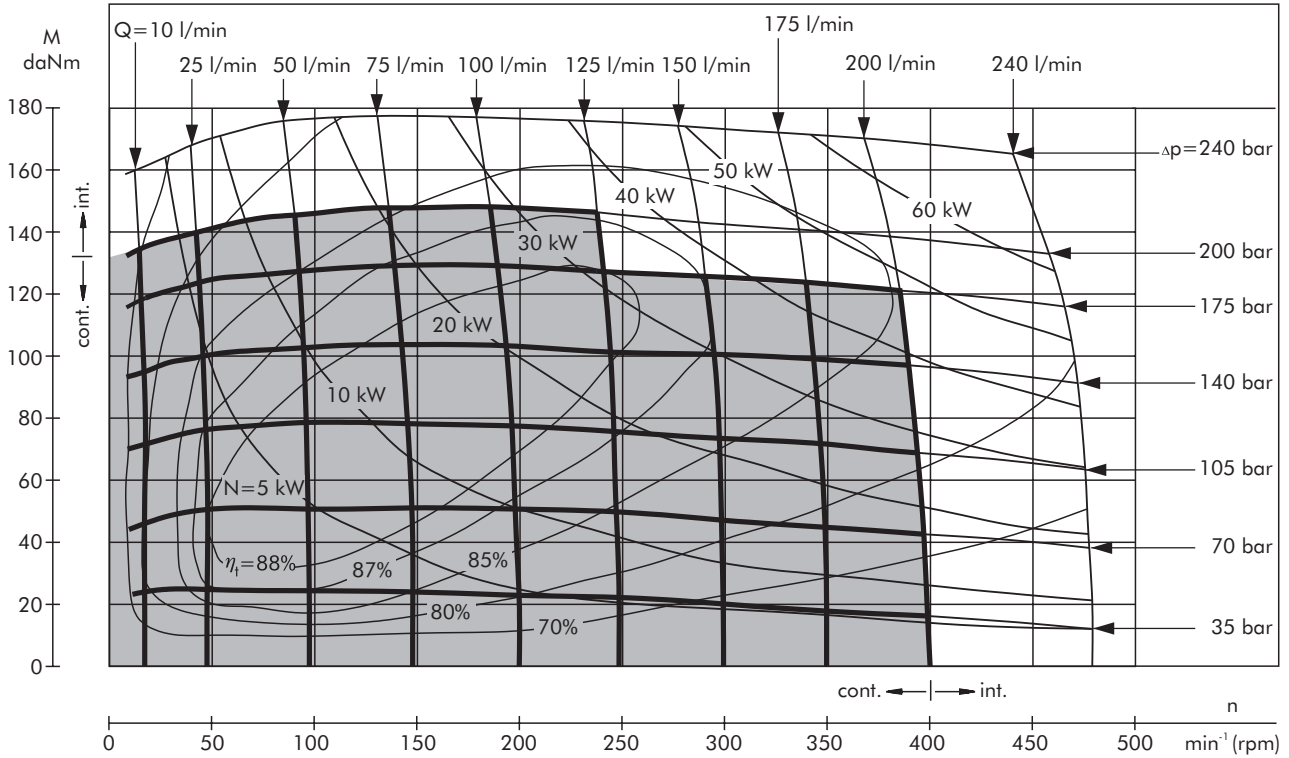

EPMV 630

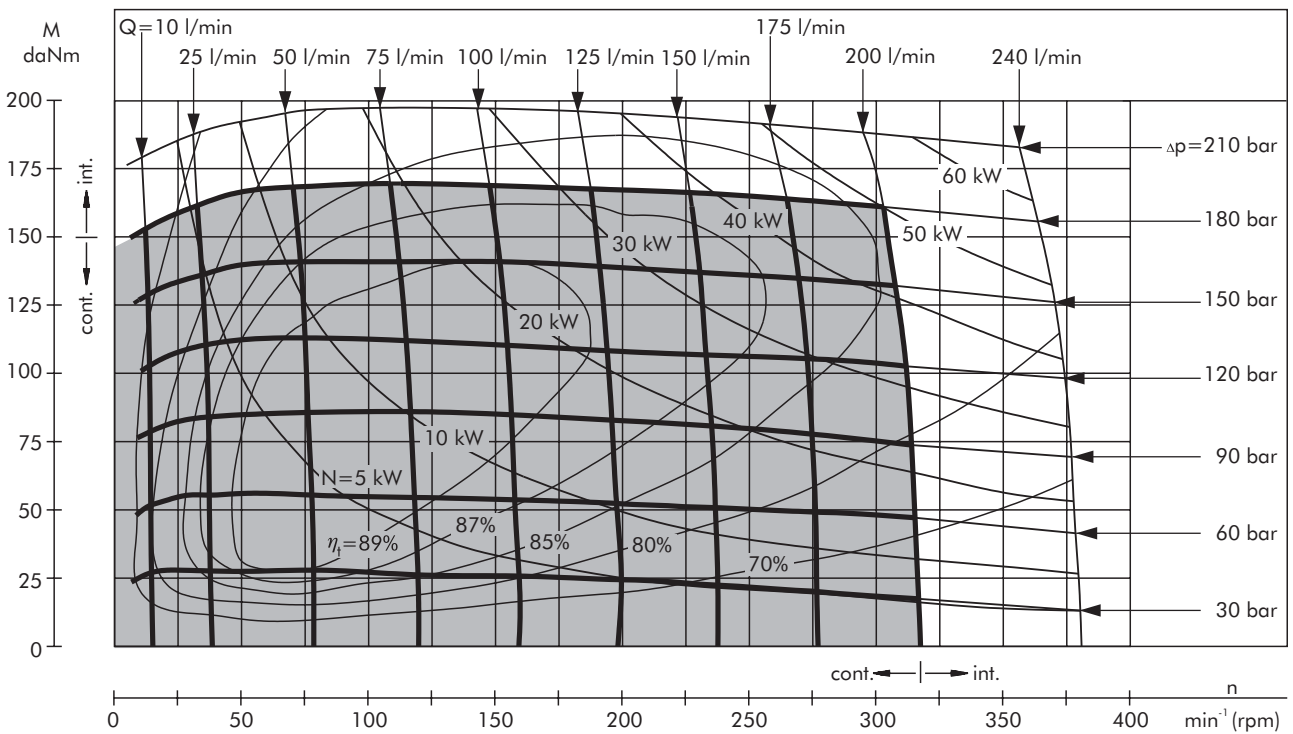

The function diagrams data was collected at back pressure 5 ÷ 10 bar and oil with viscosity of 32 mm²/s at 50° C.

FUNCTION DIAGRAMS

EPMV 800

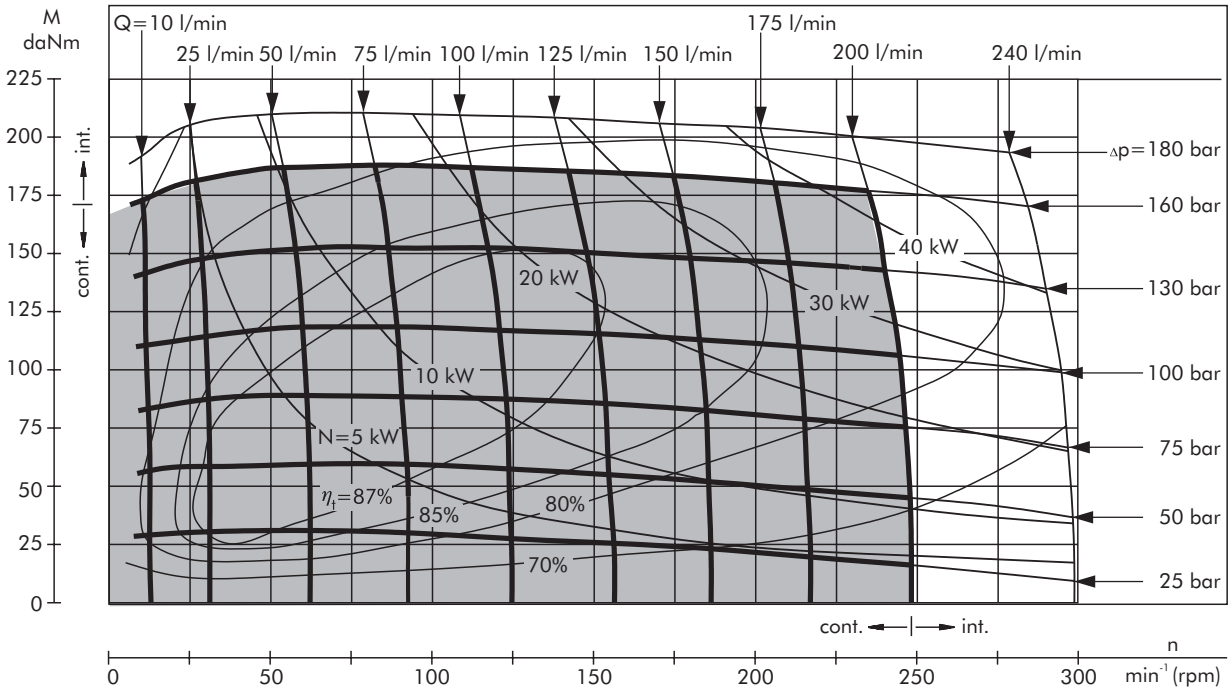

The function diagrams data was collected at back pressure 5 ÷ 10 bar and oil with viscosity of 32 mm²/s at 50° C.

PERMISSIBLE SHAFT LOADS

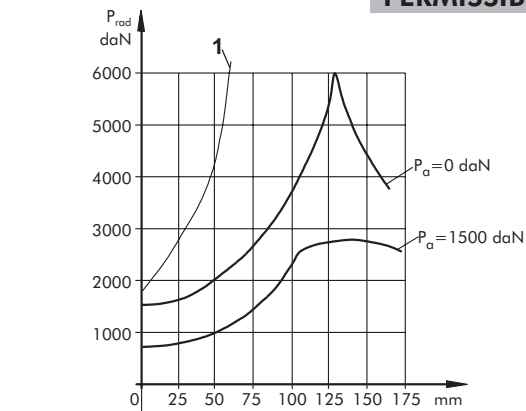

The output shaft runs in tapered bearings that permit high axial and radial forces. Curve "1" shows max. radial shaft load. Any shaft load exceeding the values quoted in the curve will seriously reduce motor life. The two other curves apply to a B10 bearing life of 3000 hours at 200 RPM.

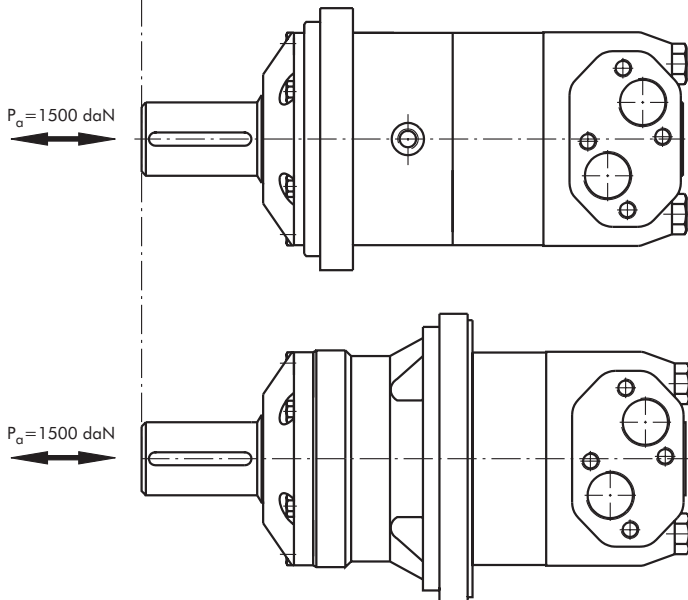

DIMENSIONS AND MOUNTING DATA

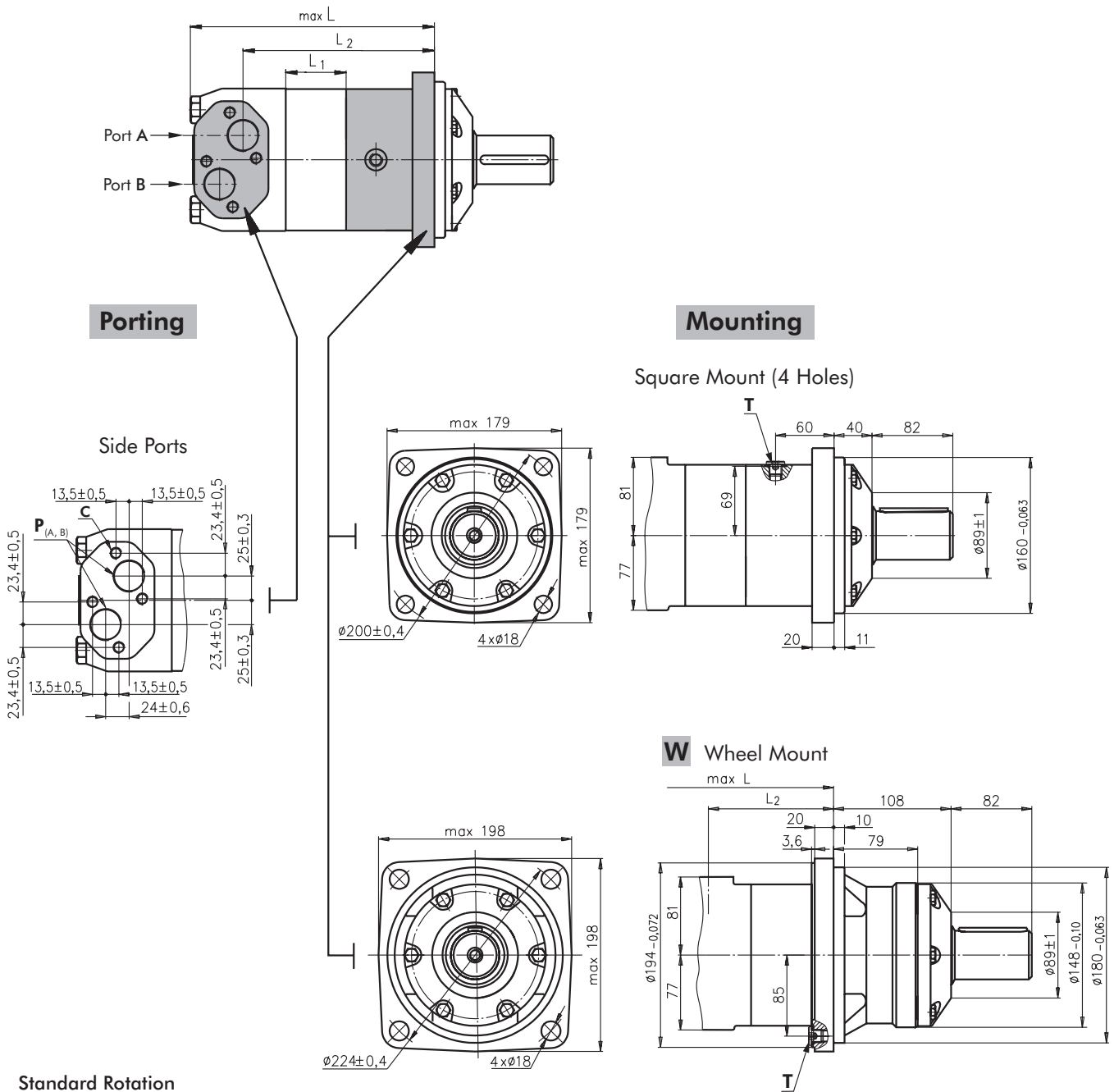

Standard Rotation
 Viewed from Shaft End
 Port A Pressurized - CW
 Port B Pressurized - CCW

Reverse Rotation
 Viewed from Shaft End
 Port A Pressurized - CCW
 Port B Pressurized - CW

C: 4xM12- 12 mm depth
P_(A,B): 2xG1 - 20 mm depth
T: G 1/4 - 12 mm depth

Type	L, mm	L ₂ , mm	Type	L, mm	L ₂ , mm	*L ₁ , mm
EPMV 315	214,5	160	EPMVW 315	146	92	22,0
EPMV 400	221,5	167	EPMVW 400	153	99	29,0
EPMV 500	229,5	175	EPMVW 500	161	107	37,0
EPMV 630	240,0	186	EPMVW 630	172	118	47,5
EPMV 800	254,0	200	EPMVW 800	185	132	61,5

* The width of the gerolator is 3,5 mm greater than L₁.

DIMENSIONS AND MOUNTING

S Short Mount

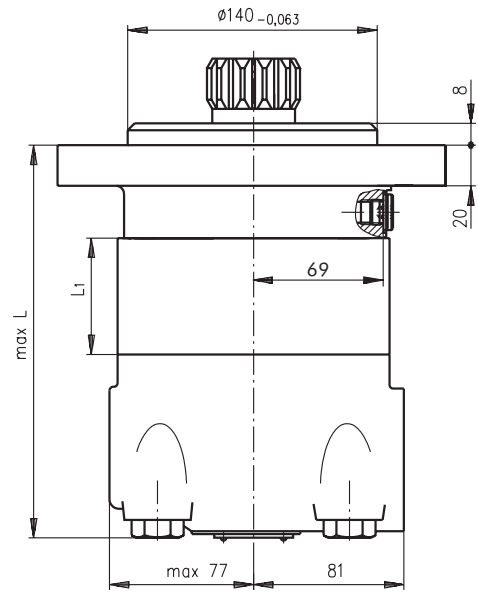
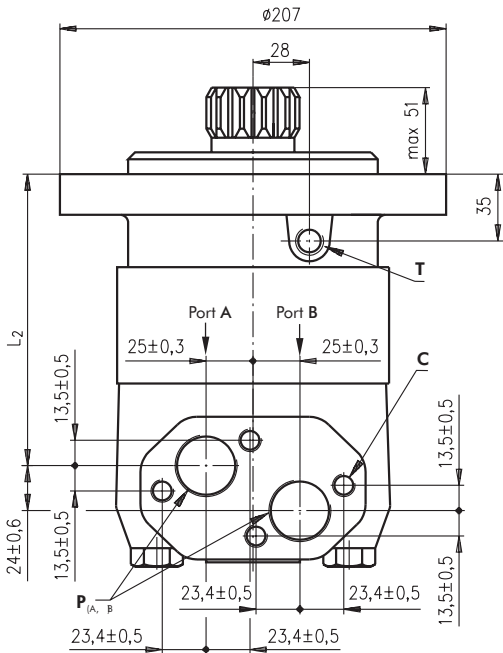

Type	L, mm	*L ₁ , mm	L ₂ , mm
EPMVS 315	171	22,0	117
EPMVS 400	179	29,0	124
EPMVS 500	186	37,0	132
EPMVS 630	197	47,5	143
EPMVS 800	211	61,5	157

C: 4xM12- 12 mm depth
P_(A,B): 2xG1 - 20 mm depth
T: G 1/4 - 12 mm depth

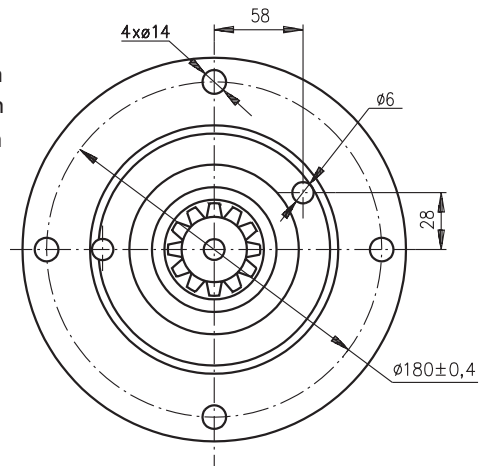

* The width of the gerolor is 3,5 mm greater than L₁.

Standard Rotation

Viewed from Shaft End
 Port A Pressurized - CW
 Port B Pressurized - CCW

Reverse Rotation

Viewed from Shaft End
 Port A Pressurized - CCW
 Port B Pressurized - CW

DIMENSIONS OF THE ATTACHED COMPONENT

EPMVS

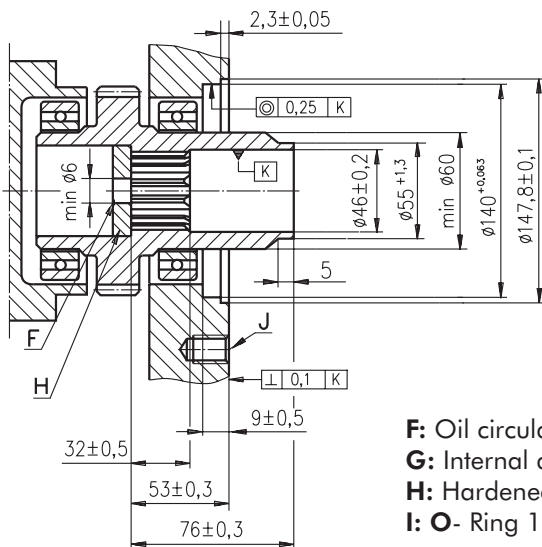

F: Oil circulation hole
G: Internal drain channel
H: Hardened stop plate
J: 4xM12-18 mm depth, 90°

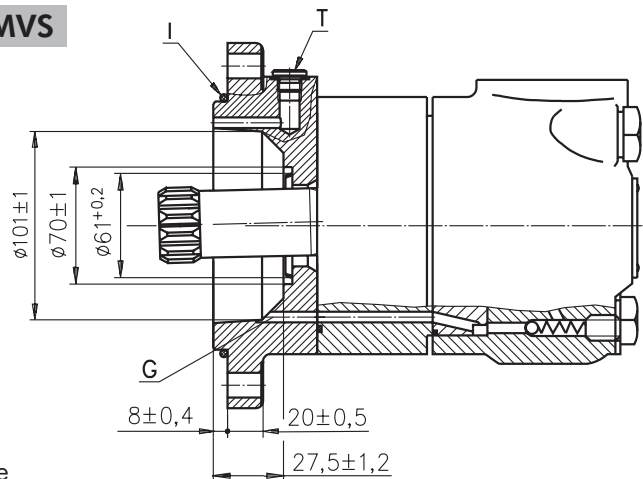

T: Drain connection G1/4 - 12 mm depth
I: O - Ring 140x3mm

DRAIN CONNECTION

A drain line ought to be used when pressure in the return line can exceed the permissible pressure. It can be connected for EPMVS at the drain port of the motor.

The drain line must be possible for oil to flow freely between motor and attached component and must be led to the tank. The maximum pressure in the drain line is limited by the attached component and its seal.

INTERNAL SPLINE DATA FOR THE ATTACHED COMPONENT

Standard ANSI B92.1-1976, class 5
[$m=2.54$; corrected $x.m=+1,0$]

Fillet Root Side Fit		mm
Number of Teeth	z	16
Diametral Pitch	DP	10/20
Pressure Angle		30°
Pitch Dia.	D	40,640
Major Dia.	D _{ri}	45,2 ^{+0,4}
Minor Dia.	D _i	38,5 ^{+0,039}
Space Width [Circular]	L _o	5,18±0,037
Fillet Radius	R _{min}	0,4
Max. Measurement between Pin	L	32,47 ^{+0,15}
Pin Dia.	d	5,5±0,001

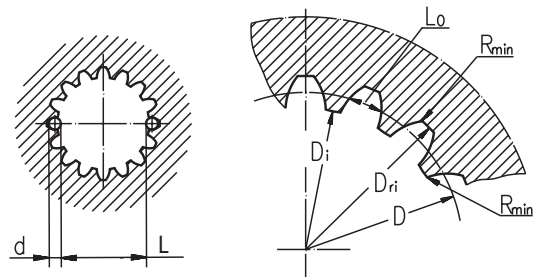

Hardening Specification:

HRC 60±2

HRC 52

0,7±0,2 mm effective case depth

Material 20 MoCr4 DIN 17210 or better

MOTOR WITH TACHO CONNECTION

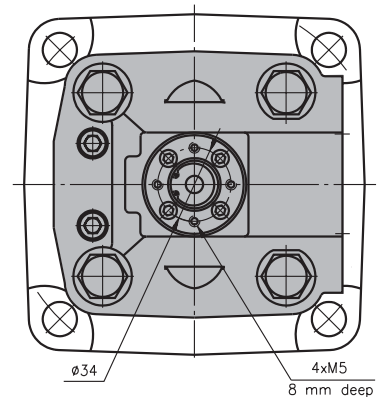
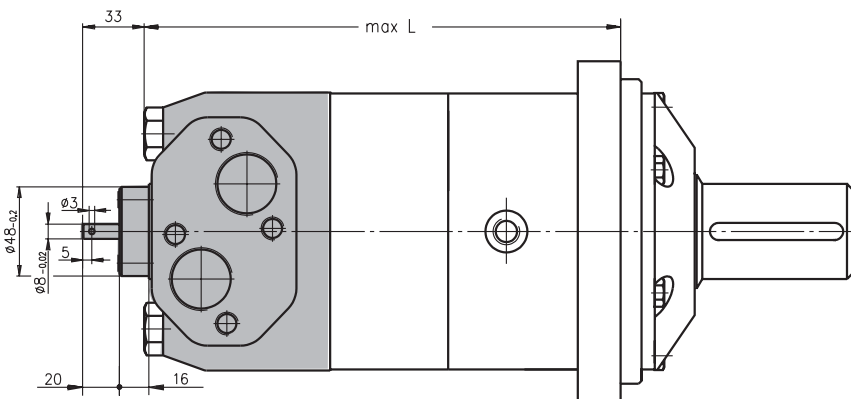

SHAFT EXTENSIONS

C - $\varnothing 50$ straight, Parallel key A14x9x70 DIN 6885

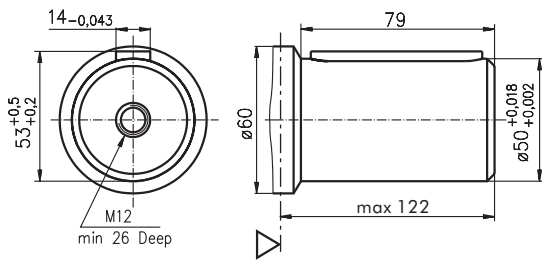

CO - $\varnothing 2\frac{1}{4}$ " [57,15] straight, Parallel key $\frac{1}{2}$ " x $\frac{1}{2}$ " x $2\frac{1}{4}$ " BS46

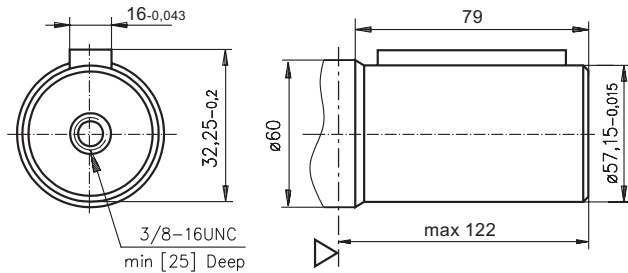

SH - $\varnothing 2\frac{1}{8}$ " splined, 16 DP 8/16 ANSI B92.1-1976

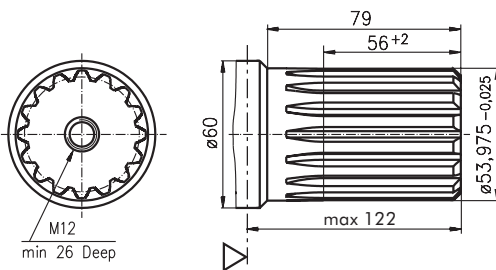

K - tapered 1:10, Parallel key B16x10x32 DIN 6885

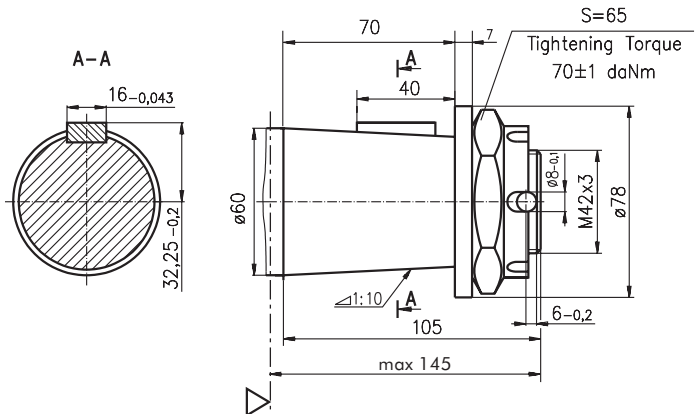

▽ - Motor Mounting Surface

ORDER CODE

1	2	3	4	5	6	7	8
E P M V							

Pos. 1 - Mounting Flange

omit - Square mount, four holes

S - Short mount

W* - Wheel mount

Pos. 2 - Displacement code

315 - 314,5 [cm³/rev]

400 - 400,9 [cm³/rev]

500 - 499,6 [cm³/rev]

630 - 629,1 [cm³/rev]

800 - 801,8 [cm³/rev]

Pos. 3 - Shaft extensions**

C - $\varnothing 50$ straight, Parallel key A14x9x70 DIN6885

CO - $\varnothing 2\frac{1}{4}$ " straight, Parallel key $\frac{1}{2}$ " x $\frac{1}{2}$ " x $2\frac{1}{4}$ " BS46

K - $\varnothing 60$ tapered 1:10, Parallel key B16x10x32 DIN6885

SH - $\varnothing 2\frac{1}{8}$ " splined, ANSI B92.1-1976

Pos. 4 - Speed Monitoring

omit - none

T - with tachometer connection

Pos. 5 - Special Features

omit - none

LL - Low Leakage

LSV - Low Speed Valve

Pos. 6 - Rotation

omit - Standard Rotation

R - Reverse Rotation

Pos. 7 - Option (Paint)***

omit - no Paint

P - Painted

PC - Corrosion Protected Paint

Pos. 8 - Design Series

omit - Factory specified

NOTES:

* The motor type EPMVW is only available with shaft type **C**, **CO**, **K**.

** The permissible output torque for shafts must not be exceeded!

*** Color at customer's request.

The hydraulic motors are manganese-phosphatized as standard.