

# CILINDROS D.E. CHARNELA TRASERA [8300]

Bottom-hinge D.A. cylinders [8300] / Vérins D.E. avec charnière arrière [8300]

D.W. Hydraulikzylinder mit Lasche am Zylinderboden [8300]

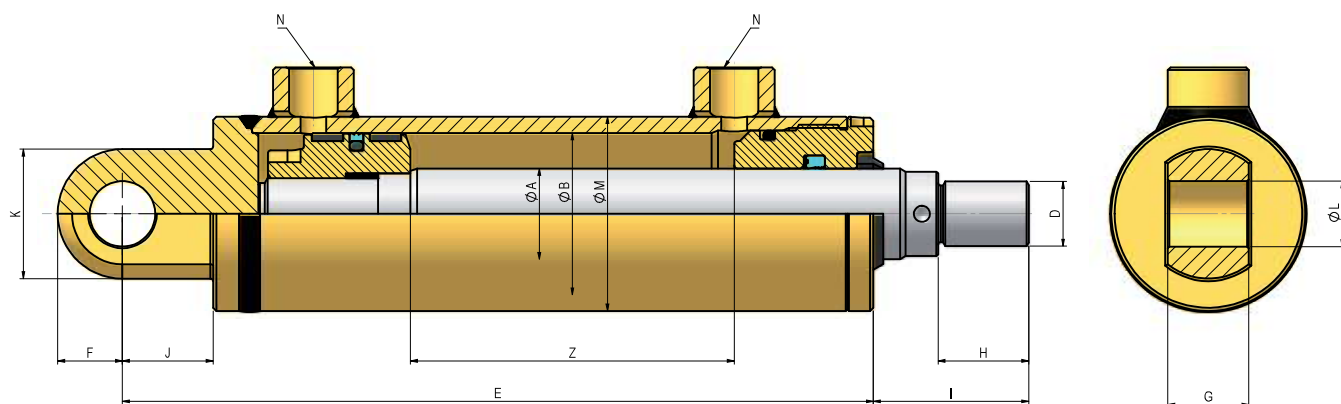

## SERIE 8300 / SERIES 8300 / SÉRIE 8300 / SERIE 8300

REF.	ØA	ØB	E	D	F	G	H	I	J	K	L	M	N BSP
8300/Z	20	32	127+Z	M14x1.5	13	16	18	35	20	26	12.2	42	1/4
8301/Z	22	40	122+Z	M16x1.5	16	20	22	40	25	32	16.2	50	3/8
8302/Z	25	40	122+Z	M16x1.5	16	20	22	40	25	32	16.2	50	3/8
8303/Z	28	40	122+Z	M16x1.5	16	20	22	40	25	32	16.2	50	3/8
8304/Z	25	50	132+Z	M20x1.5	20	25	28	48	28	40	20.25	60	3/8
8305/Z	28	50	132+Z	M20x1.5	20	25	28	48	28	40	20.25	60	3/8
8306/Z	30	50	132+Z	M20x1.5	20	25	28	48	28	40	20.25	60	3/8
8307/Z	36	50	132+Z	M20x1.5	20	25	28	48	28	40	20.25	60	3/8
8308/Z	30	60	138+Z	M27x2	25	32	36	58	32	50	25.25	70	3/8
8309/Z	35	60	138+Z	M27x2	25	32	36	58	32	50	25.25	70	3/8
8310/Z	40	60	138+Z	M27x2	25	32	36	58	32	50	25.25	70	3/8
8311/Z	36	63	138+Z	M27x2	25	32	36	58	32	50	25.25	75	3/8
8312/Z	40	63	138+Z	M27x2	25	32	36	58	32	50	25.25	75	3/8
8313/Z	45	63	138+Z	M27x2	25	32	36	58	32	50	25.25	75	3/8
8314/Z	35	70	146+Z	M27x2	25	32	36	58	32	50	25.25	80	3/8
8315/Z	40	70	146+Z	M27x2	25	32	36	58	32	50	25.25	80	3/8
8316/Z	45	70	146+Z	M27x2	25	32	36	58	32	50	25.25	80	3/8
8317/Z	36	80	171+Z	M33x2	32	40	45	68	45	64	32.5	95	3/8
8318/Z	40	80	171+Z	M33x2	32	40	45	68	45	64	32.5	95	3/8
8319/Z	45	80	171+Z	M33x2	32	40	45	68	45	64	32.5	95	3/8
8320/Z	50	80	171+Z	M33x2	32	40	45	68	45	64	32.5	95	3/8
8321/Z	56	80	171+Z	M33x2	32	40	45	68	45	64	32.5	95	3/8
8322/Z	45	100	193+Z	M42x2	40	50	56	85	55	80	40.5	115	1/2
8323/Z	50	100	193+Z	M42x2	40	50	56	85	55	80	40.5	115	1/2
8324/Z	56	100	193+Z	M42x2	40	50	56	85	55	80	40.5	115	1/2
8325/Z	60	100	193+Z	M42x2	40	50	56	85	55	80	40.5	115	1/2
8326/Z	70	100	193+Z	M42x2	40	50	56	85	55	80	40.5	115	1/2
8327/Z	70	125	275+Z	M48x2	50	60	63	92	65	100	50.5	145	3/4
8328/Z	90	125	275+Z	M48x2	50	60	63	92	65	100	50.5	145	3/4
8329/Z	80	140	295+Z	M64x3	56	65	85	120	70	112	56.5	160	3/4
8330/Z	90	160	313+Z	M80x3	63	80	95	130	75	126	63.5	180	1
8331/Z	110	160	313+Z	M80x3	63	80	95	130	75	126	63.5	180	1
8332/Z	110	200	373+Z	M80x3	80	100	95	130	95	160	80.5	230	1

Z = carrera (a definir por el cliente) / Z = stroke (to be defined by customer)

Z = course (à définir par le client) / Z = Hub (vom Kunden festzulegen)