

## 13.1 - FINECORSA IN TRAZIONE E SPINTA NORMALMENTE APERTO

TIPO/TYPE  
V-FCR 1T

## 13.1 - END STROKE VALVES, NORMALLY OPENED



SCHEMA IDRAULICO  
HYDRAULIC DIAGRAM

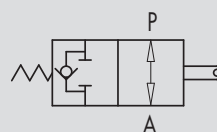

### IMPIEGO:

Valvola utilizzata per bloccare l'immissione di olio in un circuito idraulico o per fermare la corsa di un attuatore (valvola normalmente aperta). La chiusura della valvola, ottenuta azionando il cursore in trazione o spinta, permette un arresto immediato e totale del flusso di olio.

### MATERIALI E CARATTERISTICHE:

**Corpo:** ghisa

**Componenti interni:** acciaio temprato termicamente e rettificato

**Guarnizioni:** BUNA N standard

**Tenuta:** trafilemento trascurabile

### MONTAGGIO:

Collegare P al distributore e A al circuito o all'attuatore. Con il cursore azionato il flusso è bloccato da P ad A mentre, nella direzione opposta, la valvola di ritegno permette il libero passaggio dell'olio da A a P.

### USE AND OPERATION:

This valve is used to stop oil inlet in a hydraulic circuit or to stop actuator's stroke (normally opened valve). The valve closing, obtained by pulling or pushing the slider, allows an immediate and total stop of the oil flow.

### MATERIAL AND FEATURES

**Body:** cast iron

**Internal parts:** grounded and hardened steel

**Seals:** BUNA N standard

**Tightness:** minor leakage

### APPLICATIONS:

Connect P to the distributor and A to the circuit or to the actuator. When slider is operating, flow is blocked from P towards A, whilst the check valve enables free oil flow in the reverse direction (from A towards P).

### PERDITE DI CARICO PRESSURE DROPS CURVE

Temperatura olio: 50°C - Viscosità olio: 30 cSt  
Oil temperature: 50°C - Oil viscosity: 30 cSt

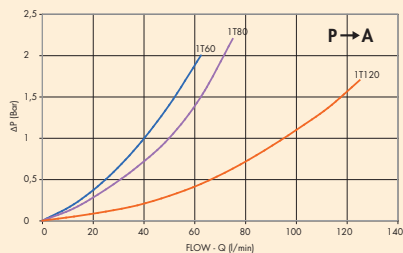



CODICE CODE	SIGLA TYPE	PORTATA MAX MAX FLOW L <sub>1</sub> /min	PRESSIONE MAX MAX PRESSURE Bar	INIZIO CHIUSURA START CLOSING mm	FORZA POWER Kg (±10%)	CORSA MAX MAX STROKE mm	FORZA POWER Kg (±10%)
<b>V0824</b>	VFCR 1T 60	60	350	7	6,5	20,5	18
<b>V0826</b>	VFCR 1T 80	80	350	7	6,5	20,5	18
<b>V0825</b>	VFCR 1T 120	120	350	9	33	15,5	50

VFCR 1T 60 - 80

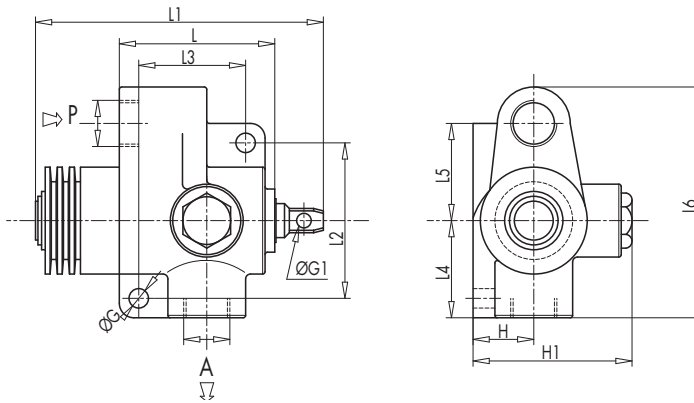

VFCR 1T 120

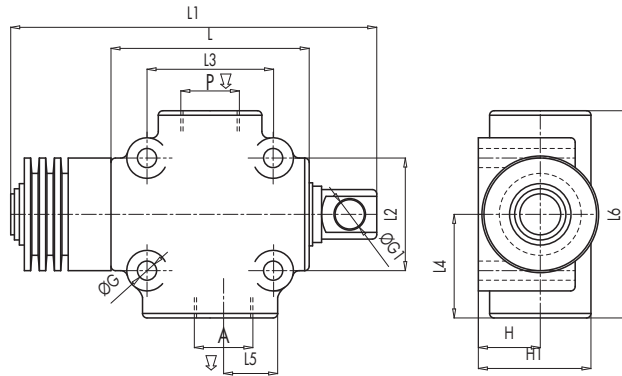

13

CODICE CODE	SIGLA TYPE	A-P	L	L1	L2	L3	L4	L5	L6	ØG	ØG1	H	H1	PESO WEIGHT
		GAS	mm	mm	mm	mm	mm	mm	mm	mm	mm	mm	mm	Kg
<b>V0824</b>	VFCR 1T 60	G 3/8"	69	130	66	45	45	41	103	8,5	6,5	26	68	1,628
<b>V0826</b>	VFCR 1T 80	G 1/2"	69	130	66	45	45	41	103	8,5	6,5	26	68	1,616
<b>V0825</b>	VFCR 1T 120	G 3/4"	88	173	50	56	46	23,5	92	8,5	13	27,5	50	2,112