



# GB1

## 2-WAY HIGH PRESSURE BALL VALVES

Edition. 21.1

### CS Carbon Steel

- Type: forged ball valve 2 way
- Sizes: from DN32 up to DN50
- Ends: BSP-NPT-SAE
- Pressure: up to PN420
- Temp range: from -30°C to +100°C (body -46°C)

### SS Stainless Steel

- Type: forged ball valve 2 way
- Sizes: from DN32 up to DN50
- Ends: BSP-NPT-SAE
- Pressure: up to PN420
- Temp range: from -30°C to +100°C (body -46°C)

DNV Certified

### STANDARD COMPOSITION OF VALVE

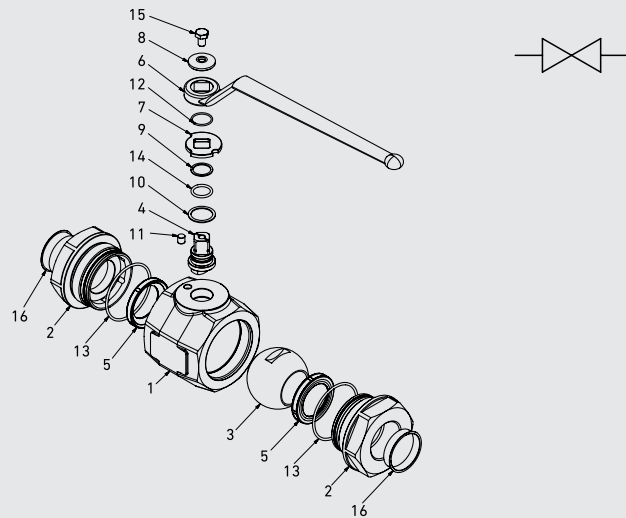

POS	DESCRIPTION	Q.TY	CS	SS
			Carbon Steel	Stainless Steel
			MATERIAL	
1	Body	1	1,0570	1,4404
2	Adapter	2	1,0570	1,4404
3	Ball	1	1,0737	1,4404
4	Stem	1	1,0737	1,4301
5	Ball seat	2	POM	POM
6	Handle	1	1,0116	1,0116
7	Washer	1	1,0116	1,4031
8	Washer	1	1,0737	1,4031
9	Back-up	1	PTFE	PTFE
10	Stem ring	1	POM	POM
11	Pin	1	1,0737	1,4404
12	Seeger	1	1,4301	1,4301
13	Adapter o-ring	4	NBR	NBR
14	Stem o-ring	1	NBR	NBR
15	Screw	1	ISO4017 8.8	ISO4017 A2
16	Caps	2	PVC	PVC



CODE DESCRIPTION STRUCTURE

GB1	G 1 1/2	DN32	L	L	1	1	A	B
-----	---------	------	---	---	---	---	---	---

Type and way of valve

GB1 2-way

Ends

GAS DIN/ NPT ANSI SAE  
 ISO 228 /ASME J1926-1  
 BSP B1.20.1

G 1 1/4 N 1 1/4 SAE20  
 G 1 1/2 N 1 1/2 SAE24  
 G 2 N 2 SAE32

Size

from DN32 to DN50

Body Material

- L = 1,0570
- 4 = 1,4404

Adapter material

- L = 1,0570
- 4 = 1,4404

Stem material

- 1 = 1,0737 4 = 1,4404\*
- 4 = 1,4404

Ball Material

- 1 = 1,0737 4 = 1,4404\*
- 4 = 1,4404

Seat material

A = POM D = PEEK\* G = PA612\* K = GEMPTFE\* C = PTFE\*

Seal material

B = NBR E = FKM\* F = EPDM\* L = MVQ\*

\*On request

- Reduced bore
- Special threads
- Pressure class up to PN42 MPa
- Pneumatic and electrical actuator
- Security block
- Locking device

For further special requests please consult our technical/commercial service.

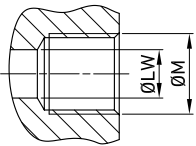
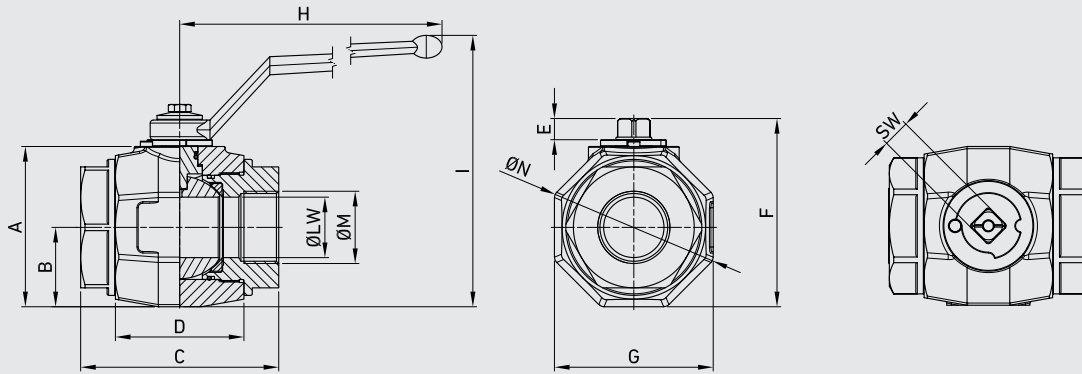

GB1 DIN/ISO 228 BSP

TYPE	DN	PN		A	B	C	D	E	F	ØN	H	I	ØM	G	SW	ØLW	WEIGHT	CS	SS		
																		Carbon Steel	Stainless Steel		
																		ITEM CODE			
GB1 G 1 1/4	32	MPa	42	mm	89	42,5	115	75	14	107,5	92	310	162,5	G 1	85	17	32	kg	4,489	GB1GGT6G0L1A000	GB1GGT6G044A000
		Psi	6090	inch	3,50	1,67	4,53	2,95	0,55	4,23	3,62	12,20	6,40	1/4	3,35	0,67	1,26	lb	9,90		
GB1 G 1 1/2	40	MPa	42	mm	106	52,5	131	85	14	124,5	113	310	179,5	G 1	105	17	40	kg	6,750	GB1GGT7G0L1A000	GB1GGT7G044A000
		Psi	6090	inch	4,17	2,07	5,16	3,35	0,55	4,90	4,45	12,20	7,07	1/2	4,13	0,67	1,57	lb	14,88		
GB1 G 2	50	MPa	42	mm	115,5	58,5	140	97,85	14	134	126	310	189	G 2	117	17	50	kg	8,708	GB1GGT8G0L1A000	GB1GGT8G044A000
		Psi	6090	inch	4,55	2,30	5,51	3,85	0,55	5,28	4,96	12,20	7,44		4,61	0,67	1,97	lb	19,20		

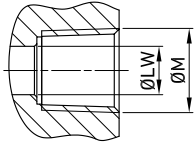
**GB1 ANSI/ASME B1.20.1 NPT**

																	CS Carbon Steel	SS Stainless Steel			
																	ITEM CODE				
TYPE	DN	PN		A	B	C	D	E	F	ØN	H	I	ØM	G	SW	ØLW	WEIGHT				
GB1 N 1 1/4	32	MPa	42	mm	89	42,5	115	75	14	107,5	92	310	162,5	N 1	85	17	32	kg	4,489	GB1NNT6G0L1A000	GB1NNT6G044A000
		Psi	6090	inch	3,50	1,67	4,53	2,95	0,55	4,23	3,62	12,20	6,40	1/4	3,35	0,67	1,26	lb	9,90		
GB1 N 1 1/2	40	MPa	42	mm	106	52,5	131	85	14	124,5	113	310	179,5	N 1	105	17	40	kg	6,774	GB1NNT7G0L1A000	GB1NNT7G044A000
		Psi	6090	inch	4,17	2,07	5,16	3,35	0,55	4,90	4,45	12,20	7,07	1/2	4,13	0,67	1,57	lb	14,93		
GB1 N 2	50	MPa	42	mm	115,5	58,5	140	97,85	14	134	126	310	189	N 2	117	17	50	kg	8,708	GB1NNT8G0L1A000	GB1NNT8G044A000
		Psi	6090	inch	4,55	2,30	5,51	3,85	0,55	5,28	4,96	12,20	7,44		4,61	0,67	1,97	lb	19,20		

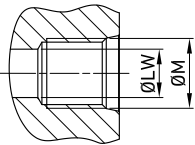
**GB1 SAE J1926-1**

																	CS Carbon Steel	SS Stainless Steel			
																	ITEM CODE				
TYPE	DN	PN		A	B	C	D	E	F	ØN	H	I	ØM	G	SW	ØLW	WEIGHT				
GB1 SAE20	32	MPa	42	mm	89	42,5	115	75	14	107,5	92	310	162,5	1 5/8	85	17	32	kg	4,489	GB1EEE5G0L1A000	GB1EEE5G044A000
		Psi	6090	inch	3,50	1,67	4,53	2,95	0,55	4,23	3,62	12,20	6,40	UNF	3,35	0,67	1,26	lb	9,90		
GB1 SAE24	40	MPa	42	mm	106	52,5	131	85	14	124,5	113	310	179,5	1 7/8	105	17	40	kg	6,822	GB1EEE6G0L1A000	GB1EEE6G044A000
		Psi	6090	inch	4,17	2,07	5,16	3,35	0,55	4,90	4,45	12,20	7,07	UNF	4,13	0,67	1,57	lb	15,04		
GB1 SAE32	50	MPa	42	mm	115,5	58,5	140	97,85	14	134	126	310	189	1 1/2	117	17	50	kg	8,708	GB1EEE7G0L1A000	GB1EEE7G044A000
		Psi	6090	inch	4,55	2,30	5,51	3,85	0,55	5,28	4,96	12,20	7,44	UNF	4,61	0,67	1,97	lb	19,20		