

# SETCO

SPECIAL ENERGY TRANSMISSION COMPONENTS



Edizione / Edition : GP 01/07-1

# Setco

## Nuova energia nelle trasmissioni di potenza. New energy for power transmission.

Dall'esperienza è nata Setco S.r.l.: una nuova realtà di mercato che punta decisamente alla qualità dei suoi prodotti e del suo servizio.

### Lanterne e giunti:

di alto standard qualitativo sono disponibili per accoppiamenti di motore-pompa.

### Raccordi pompa:

costruiti in alluminio e in acciaio, sono disponibili a tre o quattro fori a 90° e dritti. Classificati secondo l'interasse di foratura sono costruiti con le più comuni connessioni di utilizzo (GAS, DIN 2353...)

From experience was born Setco S.r.l.: a new market choice focus on quality products and service.

### Bell-housing coupling and accessories:

high-quality standard to couple motor and pump.

### Pump connectors:

made in aluminium or Steel are available with 3 or 4 mounting hole straight or elbow (90°). They are classified by the mounting interaxis and machined according to the market needs (GAS, DIN 2353...)



**SETCO**  
SPECIAL ENERGY TRANSMISSION COMPONENTS

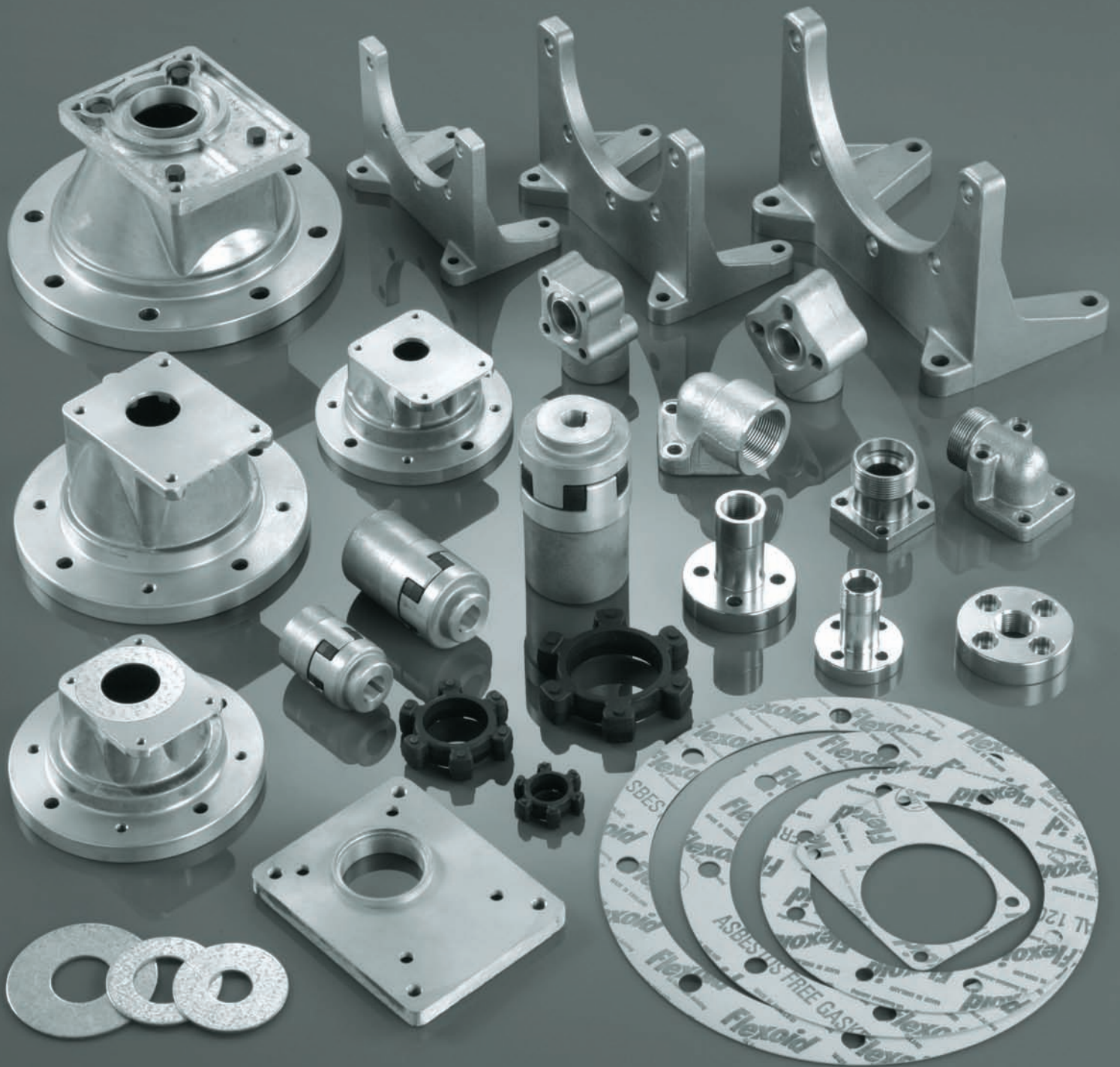

Le figure, le denominazioni, i riferimenti ed i dati contenuti nel presente catalogo non sono impegnativi. La Ditta si riserva di apportare in ogni momento e senza preavviso tutte le variazioni che riterrà opportune.

È vietata ogni riproduzione parziale od integrale delle figure e del testo senza l'autorizzazione scritta della ditta stessa. In caso di dissonanza interpretativa, fa fede il testo in italiano.

Figure, name of parts, references and dates contained in this catalogue are not binding. The firm reserves the right to introduce any and all necessary changes at any time without notice.

Either partial or integral reproductions of figures and text are forbidden unless a written authorisation is given by the Firm. In case of interpretative dissonance, the Italian text has to be considered.

Setco srl  
Via Treviglio, 44 - Brignano G. d'Adda (BG)-I  
Tel. +39 0363 817058 - Fax +39 0363 383661  
[www.setco.it](http://www.setco.it) - [info@setco.it](mailto:info@setco.it)

Pag. 3	TABELLA MOTORI ELECTRIC MOTORS TABLE
Pag. 4	FORATURA POMPE INGRANAGGI GEAR PUMPS DRILLING
Pag. 5	DESIGNAZIONE CODICE LANTERNE BELL-HOUSING DESIGNATION CODE
Pag. 6 - 7 - 8 - 9 - 10	DIMENSIONI LANTERNE PER POMPE AD INGRANAGGI BELL-HOUSING DIMENSIONS FOR GEARS PUMPS
Pag. 11	DESIGNAZIONE CODICE GIUNTO COMPLETO COMPLETE COUPLING DESIGNATION CODE
Pag. 12 - 13 - 14 - 15	DIMENSIONI GIUNTO COMPLETO COMPLETE COUPLING DIMENSIONS
Pag. 16	ANELLO DI ESTRAZIONE E CENTRAGGIO POMPA / PIEDINI CENTERING AND EXTRACTION RING / FOOT FLANGE
Pag. 17	GUARNIZIONI PER POMPE / GUARNIZIONI PER LANTERNE PUMP GASKETS / BELL-HOUSING GASKETS
Pag. 18	OBLO DI ISPEZIONE INSPECTION COVER
Pag. 19 - 20 - 21 - 22 - 23 - 24 - 25 - 26 - 27	CODICE KIT KIT CODE
Pag. 28	RACCORDO POMPA DIRITTO STRAIGHT PUMP CONNECTOR
Pag. 29	RACCORDO POMPA A 90° A 3 FORI IN ACCIAIO STEEL 90° PUMP CONNECTOR WITH 3 HOLES
Pag. 30	RACCORDO POMPA DIRITTO FILETTATO DIN 2353 STRAIGHT PUMP CONNECTOR DIN 2353 THREAD
Pag. 31	RACCORDO POMPA A 90° FILETTATO DIN 2353 90° STEEL PUMP CONNECTOR DIN 2353 THREAD
Pag. 32	RACCORDO POMPA A 90° FILETTATO GAS 90° BSP PUMP CONNECTOR
Pag. 33	RACCORDO POMPA A 90° A 4 FORI IN ALLUMINIO ALLUMINIUM 90° PUMP CONNECTOR WITH 4 HOLES
Pag. 34	RACCORDO POMPA A 90° A 3FORI IN ALLUMINIO ALLUMINIUM 90° PUMP CONNECTOR WITH 3 HOLES
Pag. 35	RACCORDO A 90° A SALDARE DI TASCA 90° SOCKET WELD CONNECTOR

# TABELLA MOTORI ELECTRIC MOTORS TABLE

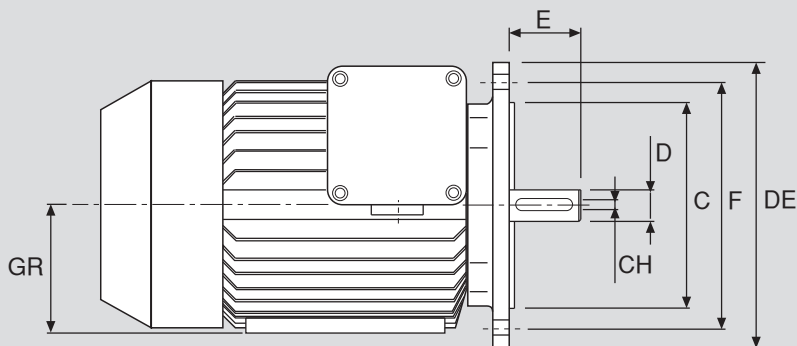

GRANDEZZA SIZE	2 Poli			4 Poli			6 Poli			8 Poli			DIMENSIONI					
	3000 rpm			1500 rpm			1000 rpm			750 rpm			DIMENSIONS					
GR	kW	T (Nm)	HP	kW	T (Nm)	HP	kW	T (Nm)	HP	kW	T (Nm)	HP	D	E	CH	C	F	DE
63	0,18 0,25	0,62 0,86	0,24 0,34	0,12 0,18	0,88 1,3	0,16 0,25	0,06 0,09	0,72 1,1	0,008 0,12	-	-	-	11	23	4	95	115	140
71	0,37 0,55	1,3 1,9	0,5 0,75	0,25 0,37	1,8 2,5	0,35 0,5	0,18 0,25	2 2,7	0,24 0,34	0,09 0,12	1,4 1,8	0,12 0,16	14	30	5	110	130	160
80	0,75 1,1	2,5 3,7	1 1,5	0,55 0,75	3,7 5,1	0,75 1	0,37 0,55	3,9 5,8	0,5 0,75	0,18 0,25	2,5 3,5	0,25 0,35	19	40	6	130	165	200
90	1,5 2,2	5 7,4	2 3	1,1 1,5	7,5 10	1,5 2	0,75 1,1	8 12	1 1,5	0,37 0,55	5,3 7,9	0,5 0,75	24	50	8	130	165	200
100	3	9,8	4	2,2 3	15 20	3 4	1,5	15	2	0,75 1,1	11 16	1 1,5	28	60	8	180	215	250
112	4	13	5,5	4	27	5,5	2,2	22	3	1,5	21	2	28	60	8	180	215	250
132	5,5 7,5	18 25	7,5 10	5,5 7,5	36 49	7,5 10	3 5,5	30 55	4 7,5	2,2 3	29 40	3 4	38	80	10	230	265	300
160	11 18,5	36 60	15 25	11 15	72 98	15 20	7,5 11	74 108	10 15	4 7,5	54 100	5,5 10	42	110	12	250	300	350
180	22	71	30	18,5 22	121 144	25 30	15	148	20	11	145	15	48	110	14	250	300	350
200	30 37	97 120	40 50	30	196	40	18,5 22	181 215	25 30	15	198	20	55	110	16	300	350	400
225	45	145	60										55	110	16	350	400	450
				37 45	240 292	50 60	30	293	40	18,5 22	244 290	25 30	60	140	18	350	400	450
250	55	177	75										60	140	18	450	500	550
				55	177	75	37	361	50	30	392	40	65	140	18	450	500	550
280	75 90	241 289	100 125										65	140	18	450	500	550
				75 90	484 581	100 125	45 55	438 535	60 75	37 45	483 587	50 60	75	140	20	450	500	550
315 S	110	353	150										65	140	18	550	600	660
				110	707	150	75 90	727 873	100 122	55	712	75	80	170	22	550	600	660

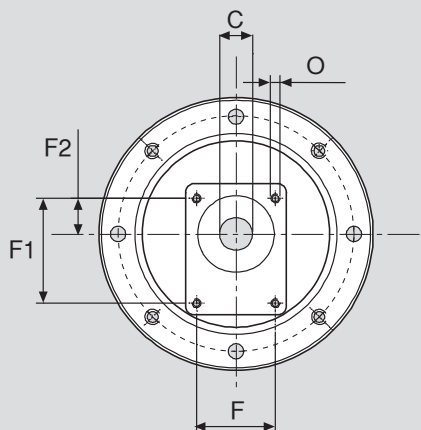

GRUPPO POMPA	CASA PRODUTTRICE TRADE MARK	CARATTERISTICHE CHARACTERISTICS	CODICE POMPA SU LANTERNA PUMP SPEC. ON BELL-H. ITEM N°	CODICE POMPA SU GIUNTO LATO POMPA PUMP SPEC. ON COUPLING ITEM N°	DIMENSIONE FORATURA POMPE SU LANTERNA PUMP DRILLING DIMENSIONS ON BELL HOUSING				
					C	F2	F1	F	O
0,5	Marzocchi-Lamborghini	(cilindrico / cylindrical Ø 6)	<b>05U</b>	<b>05M</b>	22	25,5	66	-	M6
	Standard	(cilindrico / cylindrical Ø 7)		<b>05S</b>					
1	Casappa	(cilindrico / cylindrical Ø12)	<b>1CA</b>	<b>1CA</b>	30	24,5	73	56	M6
	Marzocchi	(conicità / conical 1 : 8)	<b>1MA</b>	<b>1MA</b>	30	24,5	73	56	M6
	Standard	(conicità / conical 1 : 8)	<b>1UN</b>	<b>1UN</b>	25,4	26,2	72	52	M6
2	Standard Turola(Sauer) - Douty Salami-Iotti	Standard doppia chiave Standard double key (conicità / conical 1 : 8)	<b>2UN</b>	<b>2UN</b>	36,5	32,5	96	71,5	M8
3	Turola/Sauer-Douty	(conicità / conical 1 : 8)	<b>25T</b>	<b>3UN</b>	50,8	43	128	98,5	M8
	Marzocchi - HPI	(conicità / conical 1 : 8)	<b>3MA</b>		50,8	43	128	98,5	M10
	Standard	(conicità / conical 1 : 8)	<b>3UN</b>		50,8	42	128	98,5	M10
	Turola(Sauer)	(conicità / conical 1 : 8)	<b>3TS</b>		50,8	45	137	98,5	M10
3,5	GMM	Standard doppia chiave Standard double key (conicità / conical 1 : 8)	<b>35G</b>	<b>35U</b>	60,3	48,2	148	127	M10
	Marzocchi		<b>35M</b>		60	48,2	148	127	M12
	Standard		<b>35U</b>		60,3	49,5	149,5	114,3	M10
4	Marzocchi	Standard doppia chiave Standard double key (conicità / conical 1 : 8)	<b>4MA</b>	<b>4UN</b>	63,5	65	196	142,8	M12
	Turola/Sauer		<b>4TS</b>		63,5	64,3	188	143	M12
	Standard		<b>4UN</b>						
BOSCH	Bosch	(conicità / conical 1 : 5)	<b>ZBR</b>	<b>ZBR</b>	32	10,3	40	40	M8
	Bosch	(conicità / conical 1 : 5)	<b>ZFR</b>	<b>ZFR</b>	80	34,5	100	72	M8
	Bosch	(conicità / conical 1 : 5)	<b>ZGR</b>	<b>ZGR</b>	105	48	145	102	M10
	Bosch	(conicità / conical 1 : 5)	<b>ZNR</b>	<b>ZNR</b>	100	44,2	132	88,4	M10

# DESIGNAZIONE CODICE LANTERNA BELL-HOUSING DESIGNATION CODE

140		M *		E		4F		05U			...	
DIAMETRO LANTERNA BELL HOUSING DIAMETER		TIPOLOGIA TYPE		ANELLO DI ESTRAZIONE CENTERING RING		FORATURA LATO MOTORE MOTOR SIDE HOLES CONFIGURATION		FORATURA LATO POMPA PUMP SIDE HOLES CONFIGURATION			EVENTUALE ESECUZIONE SPECIALE SPECIAL EXECUTION	
140	Grandezza motore Motor size 63	M	Monoblocco One-piece	E	Con anello di estrazione With centering ring	4F	= 4 fori passanti + 4 fori filettati = 4 thread holes + 4 plain holes	05U	pompa / pump 0,5	Standard - Marzocchi Lamborghini		Per la codifica delle esecuzioni speciali vi preghiamo di contattare il ns.ufficio tecnico Please contact tech. dept. of SETCO S.r.l.
160	Grandezza motore Motor size 71	C	Composta Assembled			8F	= 8 fori passanti = 8 plain holes	1UN	pompa / pump 1	Standard		
200	Grandezza motore Motor size 80 - 90	* <b>ATTENZIONE!!!</b> Verificare a catalogo se la lanterna richiesta è <b>Monoblocco</b> o completa di flangia aggiuntiva (composta) <b>ATTENTION!!!</b> Verify on the catalogue if the bell-housing is <b>One-piece</b> or <b>Assembled</b> with flange		S	Senza anello di estrazione Without centering ring	1MA	pompa / pump 1	Marzocchi				
250	Grandezza motore Motor size 100 - 112					1CA	pompa / pump 1	Casappa				
300	Grandezza motore Motor size 132			2UN	pompa / pump 2	Std - Turolla/Sauer - Dowty Salami - Iotti						
350	Grandezza motore Motor size 160 - 180			25T	pompa / pump 3	Turolla/Sauer - Dowty						
400	Grandezza motore Motor size 200			3MA	pompa / pump 3	Marzocchi - HPI						
450	Grandezza motore Motor size 225			3TS	pompa / pump 3	Turolla/Sauer						
				3UN	pompa / pump 3	Standard						
				35G	pompa / pump 3,5	GMM						
		35M	pompa / pump 3,5	Marzocchi								
		35U	pompa / pump 3,5	Standard								
		4MA	pompa / pump 4	Marzocchi								
		4TS	pompa / pump 4	Turolla / Sauer								
		4UN	pompa / pump 4	Standard								
		ZBR	Bosch									
		ZFR	Bosch									
		ZGR	Bosch									
		ZNR	Bosch									

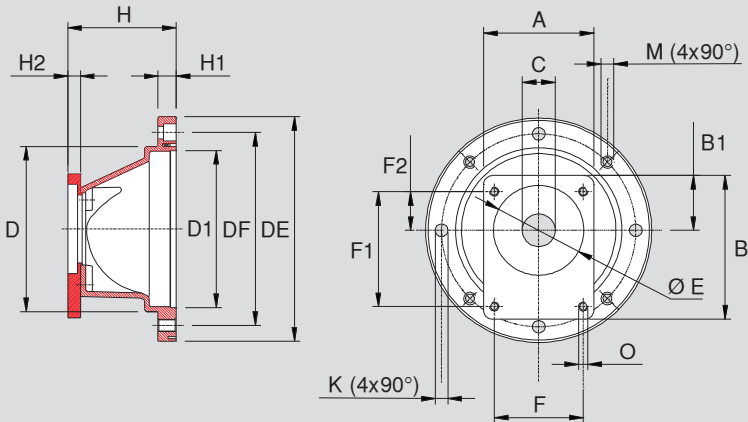

**LANTERNA COMPOSTA  
ASSEMBLED BELL HOUSING**

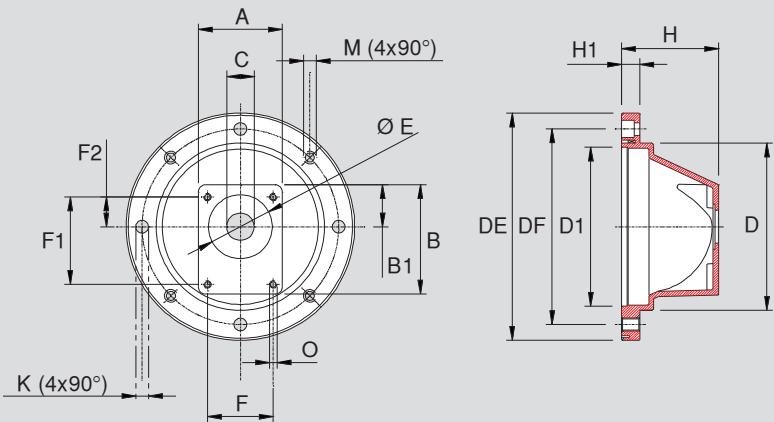

**LANTERNA MONOBLOCCO  
ONE-PIECE BELL HOUSING**

MOTORE 4 POLI 4 POLE MOTOR 1450 rpm			DIMENSIONI LANTERNA (mm) / BELL HOUSING DIMENSIONS (mm)																								
Kw	TAGLIA SIZE	HP	LANTERNA BELL HOUSING			A	B	B1	D	D1	DF	DE	H	H1	H2	K			M			C	E	F	F1	F2	O
			M	S	8F/4F											4F-8F	4F	8F	Ø	M	Ø						
0,12 ÷ 0,18	63	0,16 ÷ 0,25	140	M	S	8F/4F	05U	72	89	34,5	97	95	115	140	60	12	///	Ø 10	M8	Ø 10	22	///	///	66	25,5	M6	
							140	72	89	34,5	97	95	115	140	60	12	///	Ø 10	M8	Ø 10	22	///	///	66	25,5	M6	
							1CA	72	89	34,5	97	95	115	140	60	12	///	Ø 10	M8	Ø 10	30	///	56	73	24,5	M6	
			140	M	E	8F/4F	1MA	72	89	34,5	97	95	115	140	60	12	///	Ø 10	M8	Ø 10	30	///	56	73	24,5	M6	
							1UN	72	89	34,5	97	95	115	140	60	12	///	Ø 10	M8	Ø 10	25,4	///	52	72	26,2	M6	
							ZBR	72	89	34,5	97	95	115	140	60	12	///	Ø 10	M8	Ø 10	32	///	40	40	10,3	M8	
							1CA	72	89	34,5	97	95	115	140	60	12	///	Ø 10	M8	Ø 10	30	67,5	56	73	24,5	M6	
							1MA	72	89	34,5	97	95	115	140	60	12	///	Ø 10	M8	Ø 10	30	67,5	56	73	24,5	M6	
							1UN	72	89	34,5	97	95	115	140	60	12	///	Ø 10	M8	Ø 10	25,4	67,5	52	72	26,2	M6	
0,25 ÷ 0,37	71	0,35 ÷ 0,5	160	M	S	8F/4F	05U	72	89	34,5	110	110	130	160	70	14	///	Ø 10	M8	Ø 10	22	///	///	66	25,5	M6	
							160	72	89	34,5	110	110	130	160	70	14	///	Ø 10	M8	Ø 10	22	///	///	66	25,5	M6	
							1CA	72	89	34,5	110	110	130	160	70	14	///	Ø 10	M8	Ø 10	30	///	56	73	24,5	M6	
			160	M	E	8F/4F	1MA	72	89	34,5	110	110	130	160	70	14	///	Ø 10	M8	Ø 10	30	///	56	73	24,5	M6	
							1UN	72	89	34,5	110	110	130	160	70	14	///	Ø 10	M8	Ø 10	25,4	///	52	72	26,2	M6	
							ZBR	72	89	34,5	110	110	130	160	70	14	///	Ø 10	M8	Ø 10	32	///	40	40	10,3	M8	
							1CA	72	89	34,5	110	110	130	160	70	14	///	Ø 10	M8	Ø 10	30	67,5	56	73	24,5	M6	
							1MA	72	89	34,5	110	110	130	160	70	14	///	Ø 10	M8	Ø 10	30	67,5	56	73	24,5	M6	
							1UN	72	89	34,5	110	110	130	160	70	14	///	Ø 10	M8	Ø 10	25,4	67,5	52	72	26,2	M6	



# DIMENSIONI LANTERNE PER POMPE AD INGRANAGGI BELL-HOUSING DIMENSIONS FOR GEARS PUMPS

MOTORE 4 POLI 4 POLE MOTOR 1450 rpm			DIMENSIONI LANTERNA (mm) / BELL HOUSING DIMENSIONS (mm)																									
Kw	TAGLIA SIZE	HP	LANTERNA BELL HOUSING		A	B	B1	D	DI	DF	DE	H	H1	H2	K		M		C	E	F	F1	F2	O				
															4F-8F	4F	8F											
55 ÷ 75	80	0,75 ÷ 1,0	M	S	8F/4F	05U	90	120	45	135	130	165	200	95	15,5	///	Ø11,5	M10	Ø11,5	22	///	///	66	25,5	M6			
						05U	90	120	45	135	130	165	200	95	15,5	///	Ø11,5	M10	Ø11,5	22	///	///	66	25,5	M6			
						1CA	90	120	45	135	130	165	200	95	15,5	///	Ø11,5	M10	Ø11,5	30	///	56	73	24,5	M6			
						1MA	90	120	45	135	130	165	200	95	15,5	///	Ø11,5	M10	Ø11,5	30	///	56	73	24,5	M6			
						1UN	90	120	45	135	130	165	200	95	15,5	///	Ø11,5	M10	Ø11,5	25,4	///	52	72	26,2	M6			
						ZBR	90	120	45	135	130	165	200	95	15,5	///	Ø11,5	M10	Ø11,5	32	///	40	40	10,3	M8			
						2UN	90	120	45	135	130	165	200	95	15,5	///	Ø11,5	M10	Ø11,5	36,5	///	71,5	96	32,5	M8			
						C	S	8F/4F	25T	122	155	54	135	130	165	200	106	15,5	11	Ø11,5	M10	Ø11,5	50,8	///	98,5	128	43	M8
									3MA	122	155	54	135	130	165	200	106	15,5	11	Ø11,5	M10	Ø11,5	50,8	///	98,5	128	43	M10
									3TS	122	155	54	135	130	165	200	106	15,5	11	Ø11,5	M10	Ø11,5	50,8	///	98,4	137	45	M10
									3UN	122	155	54	135	130	165	200	106	15,5	11	Ø11,5	M10	Ø11,5	50,8	///	98,5	128	42	M10
									35G	150	175	62	135	130	165	200	110	15,5	15	Ø11,5	M10	Ø11,5	60,3	///	127	148	48,2	M10
			35U	150	175				62	135	130	165	200	110	15,5	15	Ø11,5	M10	Ø11,5	60,3	///	114,3	149,5	49,2	M10			
			M	S	8F/4F	35M	150	175	62	135	130	165	200	110	15,5	15	Ø11,5	M10	Ø11,5	60	///	127	148	48,2	M12			
						ZFR	90	120	45	135	130	165	200	95	15,5	///	Ø11,5	M10	Ø11,5	80	///	72	100	34,5	M8			
						C	S	8F/4F	ZGR	150	175	62	135	130	165	200	108,5	15,5	13,5	Ø11,5	M10	Ø11,5	105	///	102	145	48	M10
									ZNR	150	175	62	135	130	165	200	108,5	15,5	13,5	Ø11,5	M10	Ø11,5	100	///	88,4	132	44,2	M10
						M	E	8F/4F	1CA	90	120	45	135	130	165	200	95	15,5	///	Ø11,5	M10	Ø11,5	30	///	56	73	24,5	M6
									1MA	90	120	45	135	130	165	200	95	15,5	///	Ø11,5	M10	Ø11,5	30	67,5	56	73	24,5	M6
			1UN	90	120				45	135	130	165	200	95	15,5	///	Ø11,5	M10	Ø11,5	25,4	67,5	52	72	26,2	M6			
			2UN	90	120				45	135	130	165	200	95	15,5	///	Ø11,5	M10	Ø11,5	36,5	67,5	71,5	96	32,5	M8			
			25T	122	155				54	135	130	165	200	106	15,5	11	Ø11,5	M10	Ø11,5	50,8	67,5	98,5	128	43	M8			
			3MA	122	155				54	135	130	165	200	106	15,5	11	Ø11,5	M10	Ø11,5	50,8	88	98,5	128	43	M10			
			3TS	122	155				54	135	130	165	200	106	15,5	11	Ø11,5	M10	Ø11,5	50,8	88	98,4	137	45	M10			
			C	E	8F/4F				3UN	122	155	54	135	130	165	200	106	15,5	11	Ø11,5	M10	Ø11,5	50,8	88	98,5	128	42	M10
									35G	150	175	62	135	130	165	200	110	15,5	15	Ø11,5	M10	Ø11,5	60,3	88	127	148	48,2	M10
									35U	150	175	62	135	130	165	200	110	15,5	15	Ø11,5	M10	Ø11,5	60,3	88	114,3	149,5	49,2	M10
									35M	150	175	62	135	130	165	200	110	15,5	15	Ø11,5	M10	Ø11,5	60	88	127	148	48,2	M12

MOTORE 4 POLI 4 POLE MOTOR 1450 rpm			DIMENSIONI LANTERNA (mm) / BELL HOUSING DIMENSIONS (mm)																						
Kw	TAGLIA SIZE	HP	LANTERNA BELL HOUSING			A	B	B1	D	DI	DF	DE	H	H1	H2	K		M		C	E	F	F1	F2	O
																4F-8F	4F	8F							
2,2 ÷ 3	100	3 ÷ 4	M	S	8F/4F	1CA	92	121	46,5	184	180	215	250	106	20	///	Ø14,5	M12	Ø14,5	30	///	56	73	24,5	M6
						1MA	92	121	46,5	184	180	215	250	106	20	///	Ø14,5	M12	Ø14,5	30	///	56	73	24,5	M6
						1UN	92	121	46,5	184	180	215	250	106	20	///	Ø14,5	M12	Ø14,5	25,4	///	52	72	26,2	M6
						ZBR	92	121	46,5	184	180	215	250	106	20	///	Ø14,5	M12	Ø14,5	32	///	40	40	10,3	M8
						2UN	92	121	46,5	184	180	215	250	106	20	///	Ø14,5	M12	Ø14,5	36,5	///	71,5	96	32,5	M8
						25T	122	155	54	184	180	215	250	118	20	12	Ø14,5	M12	Ø14,5	50,8	///	98,5	128	43	M8
			C	S	8F/4F	3MA	122	155	54	184	180	215	250	118	20	12	Ø14,5	M12	Ø14,5	50,8	///	98,5	128	43	M10
						3TS	122	155	54	184	180	215	250	118	20	12	Ø14,5	M12	Ø14,5	50,8	///	98,4	137	45	M10
						3UN	122	155	54	184	180	215	250	118	20	12	Ø14,5	M12	Ø14,5	50,8	///	98,5	128	42	M10
						35G	150	175	62	184	180	215	250	120	20	14	Ø14,5	M12	Ø14,5	60,3	///	127	148	48,2	M10
						35U	150	175	62	184	180	215	250	120	20	14	Ø14,5	M12	Ø14,5	60,3	///	114,3	149,5	49,2	M10
						35M	150	175	62	184	180	215	250	120	20	14	Ø14,5	M12	Ø14,5	60	///	127	148	48,2	M12
			M	S	8F/4F	ZFR	92	121	46,5	184	180	215	250	106	20	///	Ø14,5	M12	Ø14,5	80	///	72	100	34,5	M8
						ZGR	150	175	62	184	180	215	250	118	20	12	Ø14,5	M12	Ø14,5	105	///	102	145	48	M10
						ZNR	150	175	62	184	180	215	250	118,5	20	12,5	Ø14,5	M12	Ø14,5	100	///	88,4	132	44,2	M10
C	S	8F/4F	1CA	92	121	46,5	184	180	215	250	106	20	///	Ø14,5	M12	Ø14,5	30	67,5	56	73	24,5	M6			
			1MA	92	121	46,5	184	180	215	250	106	20	///	Ø14,5	M12	Ø14,5	30	67,5	56	73	24,5	M6			
			1UN	92	121	46,5	184	180	215	250	106	20	///	Ø14,5	M12	Ø14,5	25,4	67,5	52	72	26,2	M6			
C	E	8F/4F	2UN	92	121	46,5	184	180	215	250	106	20	///	Ø14,5	M12	Ø14,5	36,5	67,5	71,5	96	32,5	M8			
			25T	122	155	54	184	180	215	250	118	20	12	Ø14,5	M12	Ø14,5	50,8	88	98,5	128	43	M8			
			3MA	122	155	54	184	180	215	250	118	20	12	Ø14,5	M12	Ø14,5	50,8	88	98,5	128	43	M10			
			3TS	122	155	54	184	180	215	250	118	20	12	Ø14,5	M12	Ø14,5	50,8	88	98,4	137	45	M10			
			3UN	122	155	54	184	180	215	250	118	20	12	Ø14,5	M12	Ø14,5	50,8	88	98,5	128	42	M10			
			35G	150	175	62	184	180	215	250	120	20	14	Ø14,5	M12	Ø14,5	60,3	88	127	148	48,2	M10			
C	E	8F/4F	35U	150	175	62	184	180	215	250	120	20	14	Ø14,5	M12	Ø14,5	60,3	88	114,3	149,5	49,2	M10			
			35M	150	175	62	184	180	215	250	120	20	14	Ø14,5	M12	Ø14,5	60	88	127	148	48,2	M12			

# DIMENSIONI LANTERNE PER POMPE AD INGRANAGGI BELL-HOUSING DIMENSIONS FOR GEARS PUMPS

MOTORE 4 POLI 4 POLE MOTOR 1450 rpm			DIMENSIONI LANTERNA (mm) / BELL HOUSING DIMENSIONS (mm)																												
Kw	TAGLIA SIZE	HP	LANTERNA BELL HOUSING				A	B	B1	D	DI	DF	DE	H	H1	H2	K		M		C	E	F	F1	F2	O					
																	4F-8F	4F	8F												
11 ÷ 15	160	15 ÷ 20	M	S	8F/4F	2UN	122	168	61	260	250	300	350	181	25	///	Ø 18	M16	Ø 18	36,5	///	71,5	96	32,5	M8						
						25T	122	168	61	260	250	300	350	181	25	///	Ø 18	M16	Ø 18	50,8	///	98,5	128	43	M8						
						3MA	122	168	61	260	250	300	350	181	25	///	Ø 18	M16	Ø 18	50,8	///	98,5	128	43	M10						
						3TS	122	168	61	260	250	300	350	181	25	///	Ø 18	M16	Ø 18	50,8	///	98,4	137	45	M10						
						3UN	122	168	61	260	250	300	350	181	25	///	Ø 18	M16	Ø 18	50,8	///	98,5	128	42	M10						
						ZFR	122	168	61	260	250	300	350	181	25	///	Ø 18	M16	Ø 18	80	///	72	100	34,5	M8						
						ZNR	122	168	61	260	250	300	350	181	25	///	Ø 18	M16	Ø 18	100	///	88,4	132	44,2	M10						
						ZGR	122	168	61	260	250	300	350	181	25	///	Ø 18	M16	Ø 18	105	///	102	145	48	M10						
						35M	150	175	62	260	250	300	350	195	25	14	Ø 18	M16	Ø 18	60	///	127	148	48,2	M12						
						35G	150	175	62	260	250	300	350	195	25	14	Ø 18	M16	Ø 18	60,3	///	127	148	48,2	M10						
						35U	150	175	62	260	250	300	350	195	25	14	Ø 18	M16	Ø 18	60,3	///	114,3	149,5	49,2	M10						
						4MA	170	222	78	260	250	300	350	195	25	14	Ø 18	M16	Ø 18	63,5	///	142,8	196	65	M12						
			4TS	170	222	78	260	250	300	350	195	25	14	Ø 18	M16	Ø 18	63,5	///	142,8	196	65	M12									
			4UN	170	222	78	260	250	300	350	195	25	14	Ø 18	M16	Ø 18	63,5	///	143	188	64,3	M12									
			C	E	8F/4F	25T	122	168	61	260	250	300	350	181	25	///	Ø 18	M16	Ø 18	50,8	110	98,5	128	43	M8						
						3MA	122	168	61	260	250	300	350	181	25	///	Ø 18	M16	Ø 18	50,8	110	98,5	128	43	M10						
						3TS	122	168	61	260	250	300	350	181	25	///	Ø 18	M16	Ø 18	50,8	110	98,4	137	45	M10						
						3UN	122	168	61	260	250	300	350	181	25	///	Ø 18	M16	Ø 18	50,8	110	98,5	128	42	M10						
						35M	150	175	62	260	250	300	350	195	25	14	Ø 18	M16	Ø 18	60	110	127	148	48,2	M12						
						35G	150	175	62	260	250	300	350	195	25	14	Ø 18	M16	Ø 18	60,3	110	127	148	48,2	M10						
						35U	150	175	62	260	250	300	350	195	25	14	Ø 18	M16	Ø 18	60,3	110	114,3	149,5	49,2	M10						
						4MA	170	222	78	260	250	300	350	195	25	14	Ø 18	M16	Ø 18	63,5	///	142,8	196	65	M12						
						4TS	170	222	78	260	250	300	350	195	25	14	Ø 18	M16	Ø 18	63,5	///	142,8	196	65	M12						
						4UN	170	222	78	260	250	300	350	195	25	14	Ø 18	M16	Ø 18	63,5	///	143	188	64,3	M12						
18,5 ÷ 22	180	25 ÷ 30				M	S	8F/4F	2UN	122	168	61	260	250	300	350	181	25	///	Ø 18	M16	Ø 18	36,5	///	71,5	96	32,5	M8			
									25T	122	168	61	260	250	300	350	181	25	///	Ø 18	M16	Ø 18	50,8	///	98,5	128	43	M8			
			3MA	122	168				61	260	250	300	350	181	25	///	Ø 18	M16	Ø 18	50,8	///	98,5	128	43	M10						
			3TS	122	168				61	260	250	300	350	181	25	///	Ø 18	M16	Ø 18	50,8	///	98,4	137	45	M10						
			3UN	122	168				61	260	250	300	350	181	25	///	Ø 18	M16	Ø 18	50,8	///	98,5	128	42	M10						
			ZFR	122	168				61	260	250	300	350	181	25	///	Ø 18	M16	Ø 18	80	///	72	100	34,5	M8						
			ZNR	122	168				61	260	250	300	350	181	25	///	Ø 18	M16	Ø 18	100	///	88,4	132	44,2	M10						
			ZGR	122	168				61	260	250	300	350	181	25	///	Ø 18	M16	Ø 18	105	///	102	145	48	M10						
			35M	150	175				62	260	250	300	350	195	25	14	Ø 18	M16	Ø 18	60	///	127	148	48,2	M12						
			35G	150	175				62	260	250	300	350	195	25	14	Ø 18	M16	Ø 18	60,3	///	127	148	48,2	M10						
			35U	150	175				62	260	250	300	350	195	25	14	Ø 18	M16	Ø 18	60,3	///	114,3	149,5	49,2	M10						
			4MA	170	222				78	260	250	300	350	195	25	14	Ø 18	M16	Ø 18	63,5	///	142,8	196	65	M12						
			4TS	170	222	78	260	250	300	350	195	25	14	Ø 18	M16	Ø 18	63,5	///	142,8	196	65	M12									
			4UN	170	222	78	260	250	300	350	195	25	14	Ø 18	M16	Ø 18	63,5	///	143	188	64,3	M12									
			C	E	8F/4F	25T	122	168	61	260	250	300	350	181	25	///	Ø 18	M16	Ø 18	50,8	110	98,5	128	43	M8						
						3MA	122	168	61	260	250	300	350	181	25	///	Ø 18	M16	Ø 18	50,8	110	98,5	128	43	M10						
						3TS	122	168	61	260	250	300	350	181	25	///	Ø 18	M16	Ø 18	50,8	110	98,4	137	45	M10						
						3UN	122	168	61	260	250	300	350	181	25	///	Ø 18	M16	Ø 18	50,8	110	98,5	128	42	M10						
						35M	150	175	62	260	250	300	350	195	25	14	Ø 18	M16	Ø 18	60	110	127	148	48,2	M12						
						35G	150	175	62	260	250	300	350	195	25	14	Ø 18	M16	Ø 18	60,3	110	127	148	48,2	M10						
						35U	150	175	62	260	250	300	350	195	25	14	Ø 18	M16	Ø 18	60,3	110	114,3	149,5	49,2	M10						
						4MA	170	222	78	260	250	300	350	195	25	14	Ø 18	M16	Ø 18	63,5	///	142,8	196	65	M12						
						4TS	170	222	78	260	250	300	350	195	25	14	Ø 18	M16	Ø 18	63,5	///	142,8	196	65	M12						
						4UN	170	222	78	260	250	300	350	195	25	14	Ø 18	M16	Ø 18	63,5	///	143	188	64,3	M12						

# DIMENSIONI LANTERNE PER POMPE AD INGRANAGGI BELL-HOUSING DIMENSIONS FOR GEARS PUMPS

MOTORE 4 POLI 4 POLE MOTOR 1450 rpm			DIMENSIONI LANTERNA (mm) / BELL HOUSING DIMENSIONS (mm)																							
Kw	TAGLIA SIZE	HP	LANTERNA BELL HOUSING			A	B	B1	D	DI	DF	DE	H	H1	H2	K		M		C	E	F	F1	F2	O	
																4F-8F	4F	8F								
30	200	40	M	S	8F/4F	25T	173	271	80	295	300	350	400	195	25	20	Ø 18	M16	Ø 18	50,8	///	98,5	128	43	M8	
						3MA	173	271	80	295	300	350	400	195	25	20	Ø 18	M16	Ø 18	50,8	///	98,5	128	43	M10	
						3TS	173	271	80	295	300	350	400	195	25	20	Ø 18	M16	Ø 18	50,8	///	98,4	128	45	M10	
						3UN	173	271	80	295	300	350	400	195	25	20	Ø 18	M16	Ø 18	50,8	///	98,5	128	42	M10	
						ZNR	173	271	80	295	300	350	400	195	25	20	Ø 18	M16	Ø 18	100	///	88,4	132	44,2	M10	
						ZGR	173	271	80	295	300	350	400	195	25	20	Ø 18	M16	Ø 18	105	///	102	145	48	M10	
						C	35M	173	271	80	295	300	350	400	195	25	20	Ø 18	M16	Ø 18	60	///	127	148	48,2	M12
							35G	173	271	80	295	300	350	400	195	25	20	Ø 18	M16	Ø 18	60,3	///	127	148	48,2	M10
							35U	173	271	80	295	300	350	400	195	25	20	Ø 18	M16	Ø 18	60,3	///	114,3	149,5	49,2	M10
							4MA	173	271	80	295	300	350	400	195	25	20	Ø 18	M16	Ø 18	63,5	///	142,8	196	65	M12
							4TS	173	271	80	295	300	350	400	195	25	20	Ø 18	M16	Ø 18	63,5	///	143	196	65	M12
							4UN	173	271	80	295	300	350	400	195	25	20	Ø 18	M16	Ø 18	63,5	///	143	188	64,3	M12
			M	E	8F/4F	25T	173	271	80	295	300	350	400	195	25	20	Ø 18	M16	Ø 18	50,8	110	98,5	128	43	M8	
						3MA	173	271	80	295	300	350	400	195	25	20	Ø 18	M16	Ø 18	50,8	110	98,5	128	43	M10	
						3TS	173	271	80	295	300	350	400	195	25	20	Ø 18	M16	Ø 18	50,8	110	98,4	137	45	M10	
						3UN	173	271	80	295	300	350	400	195	25	20	Ø 18	M16	Ø 18	50,8	110	98,5	128	42	M10	
						35M	173	271	80	295	300	350	400	195	25	20	Ø 18	M16	Ø 18	60	110	127	148	48,2	M12	
						35G	173	271	80	295	300	350	400	195	25	20	Ø 18	M16	Ø 18	60,3	110	127	148	48,2	M10	
						C	35U	173	271	80	295	300	350	400	195	25	20	Ø 18	M16	Ø 18	60,3	110	114,3	149,5	49,2	M10
							4MA	173	271	80	295	300	350	400	195	25	20	Ø 18	M16	Ø 18	63,5	110	142,8	196	65	M12
							4TS	173	271	80	295	300	350	400	195	25	20	Ø 18	M16	Ø 18	63,5	110	143	196	65	M12
							4UN	173	271	80	295	300	350	400	195	25	20	Ø 18	M16	Ø 18	63,5	110	143	188	64,3	M12

# DESIGNAZIONE CODICE GIUNTO COMPLETO COMPLETE COUPLING DESIGNATION CODE

10-60			S-10			10-4UN			
SEMIGIUNTO LATO MOTORE MOTOR HALF COUPLING			STELLARE SPIDER			SEMIGIUNTO LATO POMPA MOTOR HALF COUPLING			
CODICE	Ø EST.	FORO ALBERO MOTORE MOTOR SHAFT DIAMETER	CODICE	Ø EST.	DUREZZA (sh.)	CODICE	Ø EST.	GRUPPO POMPA RIFERIMENTO / CARATTERISTICHE REF. PUMP TYPE	
04-11	Ø 45	Ø 11 Grandezza motore Motor size 63	S-04	Ø 45	80Sh	4Y-05M	Ø 45	0,5	Marzocchi - Lamborghini (Ø 6)
			S-05	Ø 55	80Sh	4Y-05S	Ø 45	0,5	Standard (Ø 7)
04-14	Ø 45	Ø 14 Grandezza motore Motor size 71	S-07	Ø 74	80Sh	4Y-1CA	Ø 45	1	Casappa (Ø 12)
			S-10	Ø 104	80Sh	4Y-1MA	Ø 45	1	Marzocchi (con. 1 : 8)
04-19	Ø 45	Ø 19 Grandezza motore Motor size 80				4Y-1UN	Ø 45	1	Standard (con. 1 : 8)
04-24	Ø 45	Ø 24 Grandezza motore Motor size 90				4Y-ZBR	Ø 45		Bosch (con. 1 : 5)
						4S-05M	Ø 45	0,5	Marzocchi - Lamborghini (Ø 6)
05-19	Ø 55	Ø 19 Grandezza motore Motor size 80				4S-05S	Ø 45	0,5	Standard (Ø 7)
						4S-1CA	Ø 45	1	Casappa (Ø 12)
05-24	Ø 55	Ø 24 Grandezza motore Motor size 90				4S-1MA	Ø 45	1	Marzocchi (con. 1 : 8)
						4S-1UN	Ø 45	1	Standard (con. 1 : 8)
05-28	Ø 55	Ø 28 Grandezza motore Motor size 100-112				4S-ZBR	Ø 45		Bosch (con. 1 : 5)
						04-05M	Ø 45	0,5	Marzocchi - Lamborghini (Ø 6)
07-38	Ø 74	Ø 38 Grandezza motore Motor size 132				04-05S	Ø 45	0,5	Standard (Ø 7)
						04-1CA	Ø 45	1	Casappa (Ø 12)
10-42	Ø 104	Ø 42 Grandezza motore Motor size 160				04-1MA	Ø 45	1	Marzocchi (con. 1 : 8)
						04-1UN	Ø 45	1	Standard (con. 1 : 8)
10-48	Ø 104	Ø 48 Grandezza motore Motor size 180				04-ZBR	Ø 45		Bosch (con. 1 : 5)
						04-2UN	Ø 45	2	Standard (con. 1 : 8)
10-55	Ø 104	Ø 55 Grandezza motore Motor size 200				04-ZFR	Ø 45		Bosch (con. 1 : 5)
						05-1UN	Ø 55	1	Standard (con. 1 : 8)
10-60	Ø 104	Ø 60 Grandezza motore Motor size 225				05-1CA	Ø 55	1	Casappa (Ø 12)
						05-1MA	Ø 55	1	Standard (con. 1 : 8)
						05-2UN	Ø 55	2	Standard (con. 1 : 8)
						05-ZBR	Ø 55		Bosch (con. 1 : 5)
						05-ZFR	Ø 55		Bosch (con. 1 : 5)
						05-3UN	Ø 55	3	Standard (con. 1 : 8)
						05-35U	Ø 55	3,5	Standard (con. 1 : 8)
						05-ZGR	Ø 55		Bosch (con. 1 : 5)
						05-ZNR	Ø 55		Bosch (con. 1 : 5)
						07-2UN	Ø 74	2	Standard (con. 1 : 8)
						07-3UN	Ø 74	3	Standard (con. 1 : 8)
						07-ZFR	Ø 74		Bosch (con. 1 : 5)
						07-ZNR	Ø 74		Bosch (con. 1 : 5)
						07-35U	Ø 74	3,5	Standard (con. 1 : 8)
						07-ZGR	Ø 74		Bosch (con. 1 : 5)
						10-2UN	Ø 104	2	Standard (con. 1 : 8)
						10-3UN	Ø 104	3	Standard (con. 1 : 8)
						10-ZFR	Ø 104		Bosch (con. 1 : 5)
						10-ZNR	Ø 104		Bosch (con. 1 : 5)
						10-ZGR	Ø 104		Bosch (con. 1 : 5)
						10-35U	Ø 104	3,5	Standard (con. 1 : 8)
						10-4UN	Ø 104	4	Standard (con. 1 : 8)

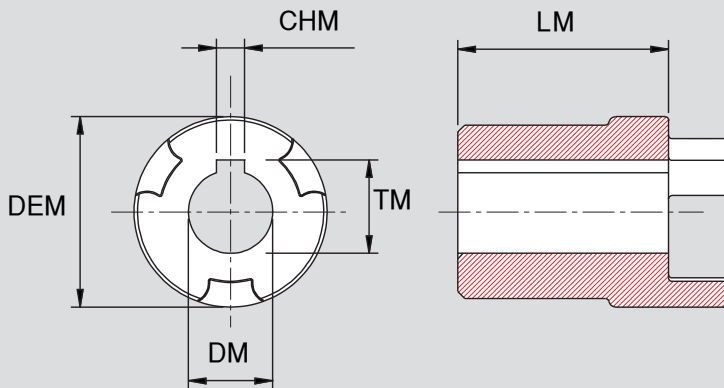

**DISEGNO 2**

**SEMIGIUNTO LATO MOTORE  
MOTOR HALF COUPLING**

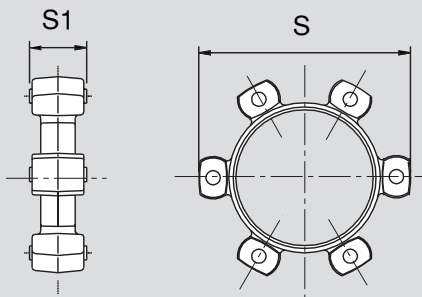

**DISEGNO 3**

**INSERTO ELASTICO (STELLARE)  
SPIDER**

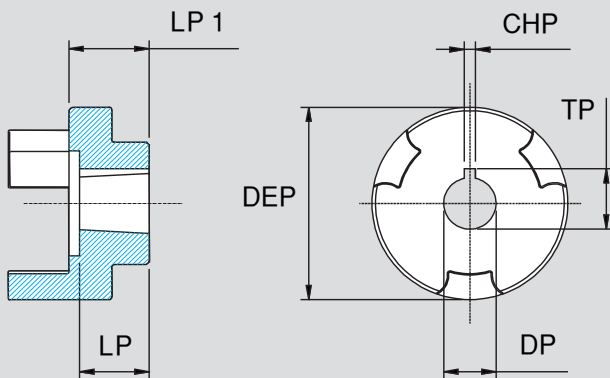

**DISEGNO 4**

**SEMIGIUNTO LATO POMPA  
PUMP HALF COUPLING**

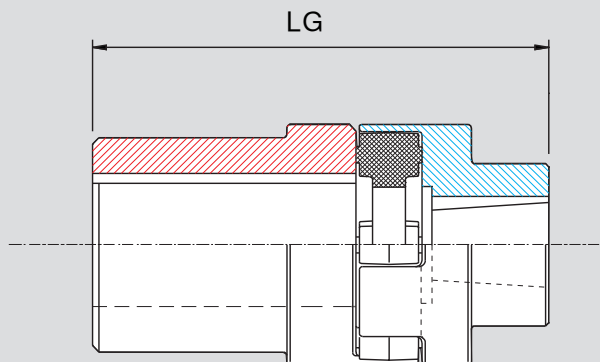

**DISEGNO 5**

**GIUNTO COMPLETO  
COUPLING ASSEMBLY**

# DIMENSIONI GIUNTO COMPLETO

## COMPLETE COUPLING DIMENSIONS

MOTORE 4 POLI 4 POLE MOTOR 1450 rpm			POMPA PUMP	SEMIGIUNTO LATO MOTORE MOTOR SIDE COUPLING	DIMENSIONI DISEGNO 2 DIMENSIONS DRAWING 2					INSERTO ELASTICO SPIDER	DIMENSIONI DISEGNO 4 DIMENSIONS DRAWING 4		SEMIGIUNTO LATO MOTORE MOTOR SIDE COUPLING	DIMENSIONI DISEGNO 4 DIMENSIONS DRAWING 4						DISEGNO 5 LUNGHEZZA GIUNTO COMPLETO DRAWING 5 ASSEMBLY COUPLING LENGHT										
Kw	TAGLIA SIZE	HP			DEM	DM	CHM	TM	LM		S	S1		TIPO* TYPE*	DEP	DP	CHP	TP	LP		LP1	LG								
0,12 ÷ 0,18	63	0,16 ÷ 0,25	05U	04-11	45	11	4	12,8	23	S - 04	45	16	4Y-05M	cil	45	6	2	7	9	15,5	54,5									
			4Y-05S										45		7	8		9	15,5	54,5										
			1CA										1:8	45	12	3	13,3	9	15	54,5										
			1MA											45	14,1	3	15,5	18	15	55,5										
			1UN											45	9,7	2,4	10,5	15,3	15,3	55,3										
			ZBR											45	9,8	2	10,5	10	12	52,5										
0,25 ÷ 0,37	71	0,35 ÷ 0,5	05U	04-14	45	14	5	16,3	30	S - 04	45	16	4S-05M	cil	45	6	2	7	9	18,5	64,5									
			4S-05S										45		7	8		9	18,5	64,5										
			1CA										1:8	45	12	3	13,3	12,5	15,5	61,5										
			1MA											45	14,1	3	15,5	18	18	64										
			1UN											45	9,7	2,4	10,5	15,3	18,3	64,3										
			ZBR											45	9,8	2	10,5	10	15	61										
0,55 ÷ 0,75	80	0,75 ÷ 1,0	05U	04-19	45	19	6	21,8	50	S - 04	45	16	04-05M	cil	45	6	2	7	9	23,5	89,5									
			04-05S										45		7	8		9	23,5	89,5										
			1CA										1:8	45	12	3	13,3	12,5	20	86										
			1MA											45	14	3	15,5	18	21	87										
			1UN											45	9,7	2,4	10,5	14,8	23,3	89,3										
			ZBR											45	9,8	2	10,5	10	20	86										
			2UN	1:8	45	17,36	3,2/4	18,5	22,5	22,5	88,5																			
			ZFR		45	16,9	3	18,2	17	20	86																			
			ZGR	1:5	55	24,9	4	21,5	26,5	28	96																			
			ZNR		55	19,8	5	27	20	30,5	98,5																			
			25T	1:8	05-3UN	05-19	55	19	6	21,8	50	S - 05	55	18	05-ZGR	1:5	55	22,2	4	23,6	28	31,5	99,5							
			05-ZNR												55		22,2	4	23,6	28	31,5	99,5								
			3MA												1:8	05-35U	55	22,2	4	23,6	28	31,5	99,5							
			3TS																					55	22,2	4	23,6	28	31,5	99,5
			3UN																					55	22,2	4	23,6	28	31,5	99,5
			35G																					55	25,6	5	27,8	34	32	100
35M	1:8	05-35U	55	25,6	5	27,8	34	32	100																					
35U										55	25,6	4,76	27,8	34	32	100														
1,1 ÷ 1,5	90	1,5 ÷ 2	05U	04-24	45	24	8	27	50	S - 04	45	16	04-05M	cil	45	6	2	7	9	23,5	89,5									
			04-05S										45		7	8		9	23,5	89,5										
			1CA										1:8	45	12	3	13,3	12,5	20	86										
			1MA											45	14	3	15,5	18	21	87										
			1UN											45	9,7	2,4	10,5	14,8	23,3	89,3										
			ZBR											45	9,8	2	10,5	10	20	86										
			2UN	1:8	45	17,36	3,2/4	18,5	22,5	22,5	88,5																			
			ZFR		45	16,9	3	18,2	17	20	86																			
			ZGR	1:5	55	24,9	4	21,5	26,5	28	96																			
			ZNR		55	19,8	5	27	20	30,5	98,5																			
			25T	1:8	05-3UN	05-24	55	24	8	27	50	S - 05	55	18	05-ZGR	1:5	55	22,2	4	23,6	28	31,5	99,5							
			05-ZNR												55		22,2	4	23,6	28	31,5	99,5								
			3MA												1:8	05-35U	55	22,2	4	23,6	28	31,5	99,5							
			3TS																					55	22,2	4	23,6	28	31,5	99,5
			3UN																					55	22,2	4	23,6	28	31,5	99,5
			35G																					55	25,6	5	27,8	34	32	100
35M	1:8	05-35U	55	25,6	5	27,8	34	32	100																					
35U										55	25,6	4,76	27,8	34	32	100														

# DIMENSIONI GIUNTO COMPLETO COMPLETE COUPLING DIMENSIONS

MOTORE 4 POLI 4 POLE MOTOR 1450 rpm			POMPA PUMP	SEMIGIUNTO LATO MOTORE MOTOR SIDE COUPLING	DIMENSIONI DISEGNO 2 DIMENSIONS DRAWING 2					INSERTO ELASTICO SPIDER	DIMENSIONI DISEGNO 4 DIMENSIONS DRAWING 4		SEMIGIUNTO LATO MOTORE MOTOR SIDE COUPLING	DIMENSIONI DISEGNO 4 DIMENSIONS DRAWING 4						DISEGNO 5 LUNGHEZZA GIUNTO COMPLETO DRAWING 5 ASSEMBLY COUPLING LENGHT												
Kw	TAGLIA SIZE	HP			DEM	DM	CHM	TM	LM		S	S1		TIPO* TYPE*	DEP	DP	CHP	TP	LP		LP1	LG										
2,2 ÷ 3	100	3 ÷ 4	1CA	05-28	55	28	8	31,3	60	S - 05	55	18	05-1CA	cil	55	12	3	13,3	12,5	19	97											
			1MA										55	14	3	15,5	19	21,5	99,5													
			1UN										1:8	55	9,7	2,4	10,5	14,5	21,5	99,5												
			2UN											55	17,36	3,2/4	18,5	22,5	21,5	99,5												
			ZBR										1:5	55	9,8	2	10,5	10	19	97												
			ZFR											55	16,9	3	18,2	19,5	19,5	97,5												
			ZGR											55	24,9	4	21,5	26,5	28	106												
			ZNR											55	19,8	5	27	20	30,5	108,5												
	25T	1:8	55										22,2	4	23,6	28	31,5	109,5														
	3MA		55										22,2	4	23,6	28	31,5	109,5														
	3TS		55										22,2	4	23,6	28	31,5	109,5														
	3UN		55										22,2	4	23,6	28	31,5	109,5														
	35G		55										25,6	5	27,8	32	34	110														
	35M		55										25,6	5	27,8	32	34	110														
	35U	55	25,6										4,76	27,8	32	34	110															
	4	112	5,5										05-3UN	07-38	74	38	10	41,3	80	S - 07	74	20	07-2UN	1:8	74	17,36	3,2/4	18,5	22	22	122	
25T				74	22,2	4	23,6	28	23,5	123,5																						
3MA				74	22,2	4	23,6	28	23,5	123,5																						
3TS				74	22,2	4	23,6	28	23,5	123,5																						
3UN				1:5	74	16,9	3	18,2	19,5	21,5	121,5																					
ZFR					74	24,9	4	21,5	27	32	132																					
ZGR					74	19,8	5	27	19	19	119																					
ZNR					74	25,6	5	27,8	35	35	135																					
35G		1:8	74	25,6	5	27,8	35	35	135																							
35M			74	25,6	5	27,8	35	35	135																							
35U			74	25,6	4,76	27,8	35	35	135																							
5,5 ÷ 9			132	7,5 ÷ 12	10-2UN	10-42	104	42	12	45,3	110	S - 10	104										24	10-2UN	1:8	104	17,36	3,2/4	18,5	22,5	40,5	174,5
		25T			104																			22,2		4	23,6	29	40,5	174,5		
		3MA			104																			22,2		4	23,6	29	40,5	174,5		
		3TS			104																			22,2		4	23,6	29	40,5	174,5		
		3UN			1:5																			104	22,2	4	23,6	29	40,5	174,5		
	ZFR	104												16,9	3	18,2	19	39	173													
	ZGR	104												24,9	5	26,3	27	36,5	170,5													
	ZNR	104												19,8	4	22,2	20	36	170													
	35M	1:8	104	25,6	5									27,8	36,5	52	186															
	35G		104	25,6	5									27,8	36,5	52	186															
	35U		104	25,6	4,76									27,8	36,5	52	186															
	4MA		104	33,3	7									35,5	44	49	183															
	4TS	1:8	104	33,3	7									35,5	44	49	183															
	4UN		104	33,3	6,35									35,5	44	49	183															
	11 ÷ 15		160	15 ÷ 20	10-2UN									10-48	104	48	12	51	110	S - 10	104	24		10-2UN	1:8	104	17,36	3,2/4	18,5	22	40,5	174,5
					25T																			104		22,2	4	23,6	29	40,5	174,5	
3MA		104			22,2	4	23,6	29	40,5	174,5																						
3TS		104			22,2	4	23,6	29	40,5	174,5																						
3UN		1:5			104	22,2	4	23,6	29	40,5	174,5																					
ZFR					104	16,9	3	18,2	19	39	173																					
ZGR					104	24,9	5	26,3	27	36,5	170,5																					
ZNR					104	19,8	4	22,2	20	36	170																					
35M		1:8	104	25,6	5	27,8	36,5	52	186																							
35G			104	25,6	5	27,8	36,5	52	186																							
35U			104	25,6	4,76	27,8	36,5	52	186																							
4MA			104	33,3	7	35,5	44	49	183																							
4TS		1:8	104	33,3	7	35,5	44	49	183																							
4UN			104	33,3	6,35	35,5	44	49	183																							
18,5 ÷ 22			180	25 ÷ 30	10-2UN	10-48	104	48	12	51	110	S - 10	104										24	10-2UN	1:8	104	17,36	3,2/4	18,5	22	40,5	174,5
					25T																			104		22,2	4	23,6	29	40,5	174,5	
	3MA	104			22,2									4	23,6	29	40,5	174,5														
	3TS	104			22,2									4	23,6	29	40,5	174,5														
	3UN	1:5			104									22,2	4	23,6	29	40,5	174,5													
	ZFR				104									16,9	3	18,2	19	39	173													
	ZGR				104									24,9	5	26,3	27	36,5	170,5													
	ZNR				104									19,8	4	22,2	20	36	170													
	35M	1:8	104	25,6	5									27,8	36,5	52	186															
	35G		104	25,6	5									27,8	36,5	52	186															
	35U		104	25,6	4,76									27,8	36,5	52	186															
	4MA		104	33,3	7									35,5	44	49	183															
	4TS	1:8	104	33,3	7									35,5	44	49	183															
	4UN		104	33,3	6,35									35,5	44	49	183															



MOTORE 4 POLI 4 POLE MOTOR 1450 rpm			POMPA PUMP	SEMIGIUNTO LATO MOTORE MOTOR SIDE COUPLING	DIMENSIONI DISEGNO 2 DIMENSIONS DRAWING 2					INSERTO ELASTICO SPIDER	DIMENSIONI DISEGNO 4 DIMENSIONS DRAWING 4		SEMIGIUNTO LATO MOTORE MOTOR SIDE COUPLING	DIMENSIONI DISEGNO 4 DIMENSIONS DRAWING 4						DISEGNO 5 LUNGHEZZA GIUNTO COMPLETO DRAWING 5 ASSEMBLY COUPLING LENGHT	
Kw	TAGLIA SIZE	HP			DEM	DM	CHM	TM	LM		S	S1		TIPO* TYPE*	DEP	DP	CHP	TP	LP		LP1
30	200	40	25T	10-55	104	55	16	59,3	110	S - 10	104	24	10-3UN	1:8	104	22,2	4	23,6	29	40,5	174,5
			104												22,2	4	23,6	29	40,5	174,5	
			104												22,2	4	23,6	29	40,5	174,5	
			104												22,2	4	23,6	29	40,5	174,5	
			10-ZGR										1:5	104	24,9	5	23,6	27	36,5	170,5	
														104	19,8	4	22,2	20	36	170	
														104	25,6	5	27,8	36,5	52	186	
			10-35U										1:8	104	25,6	5	27,8	36,5	52	186	
														104	25,6	4,76	27,8	36,5	52	186	
														104	33,3	7	35,5	44	49	183	
														104	33,3	7	35,5	44	49	183	
			10-4UN										1:8	104	33,3	6,35	35,5	44	49	183	
														104	33,3	6,35	35,5	44	49	183	
														104	33,3	6,35	35,5	44	49	183	
104	33,3	6,35		35,5	44	49	183														
37 ÷ 45	225	50 ÷ 60	25T	10-60	104	60	18	64,4	140	S - 10	104	24	10-3UN	1:8	104	22,2	4	23,6	29	40,5	174,5
			104												22,2	4	23,6	29	40,5	174,5	
			104												22,2	4	23,6	29	40,5	174,5	
			104												22,2	4	23,6	29	40,5	174,5	
			10-ZGR										1:5	104	24,9	5	23,6	27	36,5	170,5	
														104	19,8	4	22,2	20	36	170	
														104	25,6	5	27,8	36,5	52	186	
			10-35U										1:8	104	25,6	5	27,8	36,5	52	186	
														104	25,6	4,76	27,8	36,5	52	186	
														104	33,3	7	35,5	44	49	183	
														104	33,3	7	35,5	44	49	183	
			10-4UN										1:8	104	33,3	6,35	35,5	44	49	183	
														104	33,3	6,35	35,5	44	49	183	
														104	33,3	6,35	35,5	44	49	183	
104	33,3	6,35		35,5	44	49	183														

# ANELLO DI ESTRAZIONE E CENTRAGGIO POMPA CENTERING AND EXTRACTION RING

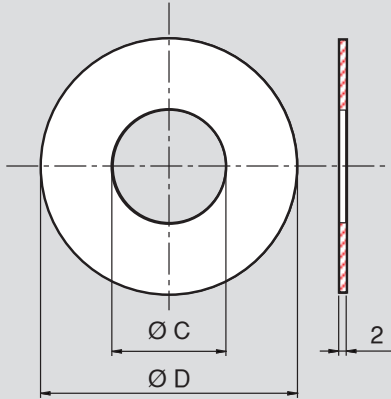

LANTERNA BELL HOUSING	ANELLO DI CENTRAGGIO CENTERING RING	DIMENSIONI DIMENSIONS		POMPA / PUMP
		Ø D	Ø C	
140 M - 160 M 200 M - 250 M	A1 254	67,5	25,4	1CA - 1UN
	A1 300	67,5	30	1MA
	A1 365	67,5	36,5	2UN
200 C - 250 C 300 M	A2 365	88	36,5	2UN
	A2 508	88	50,8	25T - 3MA - 3TS - 3UN
	A2 600	88	60	35M
	A2 603	88	60,3	35G - 35U
350 M	A3 508	110	50,8	25T - 3MA - 3TS - 3UN
	A3 600	110	60	35M
	A3 603	110	60,3	35G - 35U
	A3 635	110	63,5	4UN - 4TS - 4MA

## PIEDINI - FOOT FLANGE

Fig. A

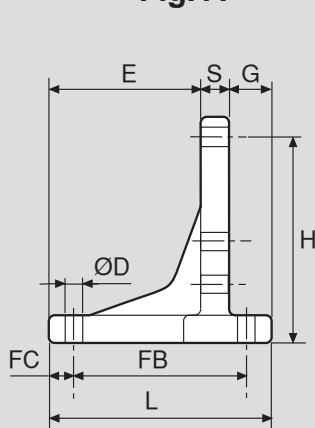
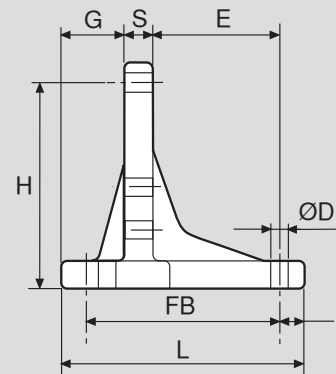
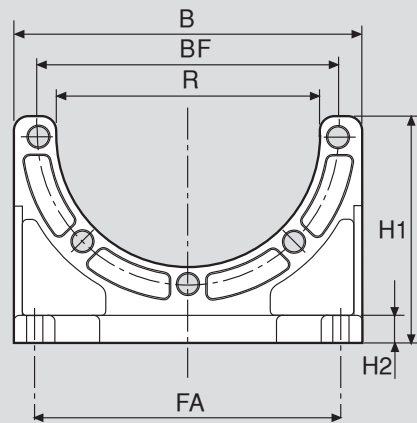

Fig. B



GRANDEZZA MOTORE MOTOR SIZE	PIEDINO FOOT FLANGE	DIMENSIONI / DIMENSIONS															LANTERNA BELL HOUSING
		FIG.	B	BF	R	FA	FB	FC	L	D	E	S	G	H	H1	H2	
71	BB 160	A	160	130	115	135	80	10	100	9	68	12	20	100	112	12	160
80 - 90	BB 200	A	200	165	140	176	103	13	128	11	88	15	25	123	138	15	200
100 - 112	BB 250	A	250	215	190	220	130	15	159	13	109	20	30	150	165	20	250
132	BB 300	A	300	265	240	265	160	18	190	13	135	20	35	180	198	20	300
160 - 180	BB 350	B	350	300	270	310	250	20	290	17	190	30	70	215	240	30	350

# GUARNIZIONI PER POMPE PUMP GASKETS

Fig. 1

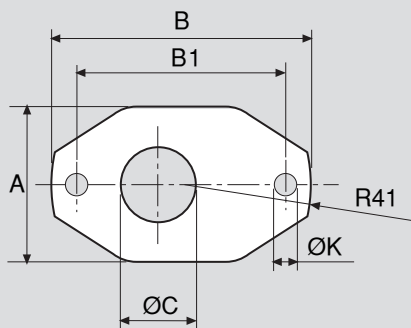
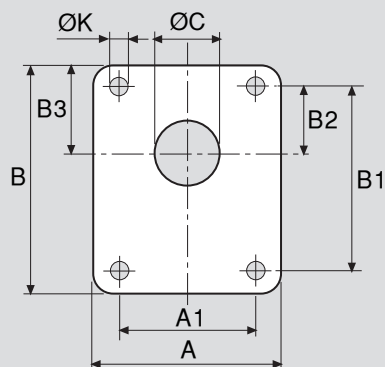
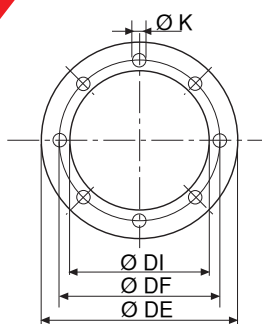

Fig.2



POMPA PUMP	GUARNIZIONE GASKET	FIG.	DIMENSIONI / DIMENSIONS							
			A	A1	B	B1	B2	B3	Ø C	Ø K
05 U	<b>GP 05U</b>	1	50	XX	82	66	25,5	33,5	23	7
Bosh ZBR	<b>GP ZBR</b>	2	65	40	75	40	10,3	28	33	9
Gr. 1 Standard	<b>GP 1UN</b>	2	70	52	90	72	26	35	26	7
Gr. 1 Marzocchi	<b>GP 1MA</b>	2	70	56	90	71,5	24,5	34	31	7
Gr. 2 Standard	<b>GP 2UN</b>	2	90	71,5	115	96	32,5	42	37,5	9
Bosh ZFR	<b>GP ZFR</b>	2	92	72	122	100	34,5	45,5	82	9
Gr. 3 Standard	<b>GP 3UN</b>	2	122	98,5	152	128	42	54	52	11
2,5 Turolla Dowty	<b>GP 25T</b>	2	122	98,5	152	128	43	54	52	11
Gr. 3 Marzocchi	<b>GP 3MA</b>	2	122	98,5	152	128	43	54	52	11
Gr. 3 Turolla Sauer	<b>GP 3TS</b>	2	122	98,4	152	137	45	54	52	11
Gr. 3,5 Standard	<b>GP 35U</b>	2	158	114,5	180	149,5	49	64	61	13
Gr. 4 Standard	<b>GP 4UN</b>	2	175	143	230	196	65	82	65	13

# GUARNIZIONI PER LANTERNE BELL-HOUSING GASKETS



Ø LANTERNA BELL-HOUSING DIAMETER	CODICE GUARNIZIONE GASKET CODE	DIMENSIONI / DIMENSIONS			
		Ø DE	Ø DF	Ø DI	Ø K
140	<b>GB 140</b>	140	115	101	10
160	<b>GB 160</b>	160	130	114	10
200	<b>GB 200</b>	200	165	141	13
250	<b>GB 250</b>	250	215	188	15
300	<b>GB 300</b>	300	265	238	15
350	<b>GB 350</b>	350	300	264	18
400	<b>GB 400</b>	400	350	300	18

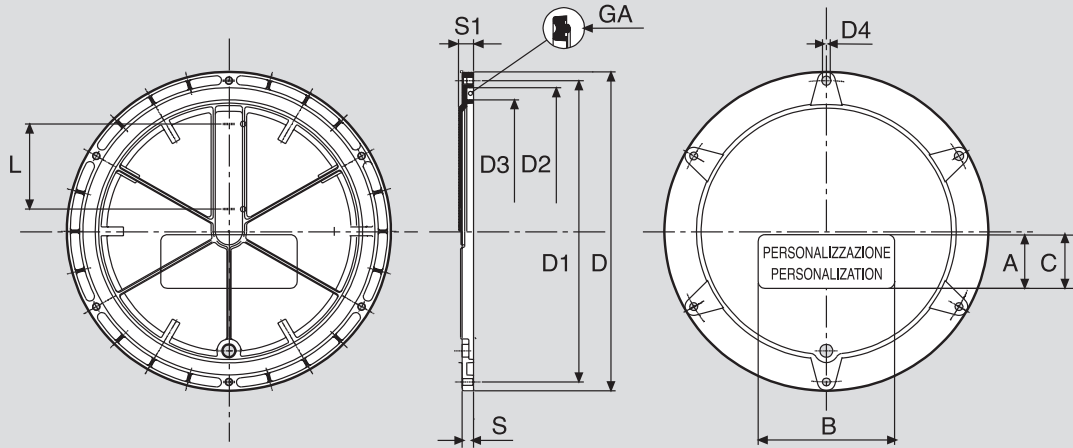

OBLÒ INSPECTION COVER	DIMENSIONI / DIMENSIONS											GUARNIZIONE SEALING
	D	D1	D2	D3	D4	S	S1	A	B	C	L	
<b>OB 275</b>	275	255	234	207	9 x 6	13,5	22,5	50	120	67,5	76	<b>GA 275 = OR 8850</b>
<b>OB 350</b>	350	324	303	267	11,5 x 4	15	22	50	160	75	127	<b>GA 350</b>
<b>OB 475</b>	475	449	428	392	11,5 x 6	17	22	80	200	85	127	<b>GA 475</b>

**CODICE D'ORDINE / ORDERING EXAMPLE**

COMPLETO / COMPLETE  
OB 350-G

SOLO OBLÒ / ONLY INSPECTION COVER  
OB 350

SOLO GUARNIZIONE / ONLY SEAL  
GA 350

# CODICE KIT KIT CODE

## GR 63 - GR 71

Qui di seguito sono elencati tutti gli accoppiamenti contemplati in questo catalogo, suddivisi per grandezza motore. Ad ogni lanterna corrisponde un giunto di trasmissione, pertanto per semplicità di utilizzo proponiamo alla clientela un codice denominato "CODICE KIT" al quale vengono associati giunto e lanterna. In questo modo, in fase d'ordine o di offerta, saremo in grado di gestire l'accoppiamento completo.

Hereinafter all the couplings included in this catalogue are listed and subdivided for engine size. Every bell-housing is related to a complete drive coupling, therefore to manage the complete coupling (bell-housing and drive coupling) we suggest to use "kit code" for orders, inquiry and offers. In this way we think to simplify your job.

MOTORE 4 POLI 4 POLE MOTOR 1450 rpm			POMPA PUMP	LANTERNA - BELL HOUSING					GIUNTO COMPLETO COMPLETE COUPLING			CODICE KIT KIT CODE			
Kw	TAGLIA SIZE	HP		Ø LANTERNA BELL HOUSING DIAM.	TIPO TYPE	ANELLO DI CENTRAGGIO CENTERING RING	FORATURA HOLES CONFIGURATION	CODICE POMPA PUMP CODE	GIUNTO LATO MOTORE MOTOR SIDE COUPLING	INSERTO ELASTICO SPIDER	GIUNTO LATO POMPA PUMP SIDE COUPLING				
0,12 ÷ 0,18	63	0,16 ÷ 0,25	05U	140	M	S	8F	05U	04-11	S - 04	4Y-05M	K010010			
			1CA					1CA			4Y-05S	K010020			
			1MA					1MA			4Y-1CA	K010030			
			1UN					1UN			4Y-1MA	K010040			
			ZBR					ZBR			4Y-1UN	K010050			
											4Y-ZBR	K010060			
			05U	140	M	S	4F	05U	04-11	S - 04	4Y-05M	K010070			
			1CA					1CA			4Y-05S	K010080			
			1MA					1MA			4Y-1CA	K010090			
			1UN					1UN			4Y-1MA	K010100			
			ZBR					ZBR			4Y-1UN	K010110			
											4Y-ZBR	K010120			
			1CA	140	M	E	8F	1CA	04-11	S - 04	4Y-1CA	K010130			
			1MA					1MA			4Y-1MA	K010140			
			1UN					1UN			4Y-1UN	K010150			
			1CA					1CA			4Y-1CA	K010160			
			1MA	140	M	E	4F	1MA	04-11	S - 04	4Y-1MA	K010170			
			1UN					1UN			4Y-1UN	K010180			
			0,25 ÷ 0,37	71	0,35 ÷ 0,5	05U	160	M	S	8F	05U	04-14	S - 04	4S-05M	K020010
						1CA					1CA			4S-05S	K020020
1MA	1MA	4S-1CA				K020030									
1UN	1UN	4S-1MA				K020040									
ZBR	ZBR	4S-1UN				K020050									
		4S-ZBR				K020060									
05U	160	M				S	8F	05U	04-14	S - 04	4S-05M	K020070			
1CA								1CA			4S-05S	K020080			
1MA								1MA			4S-1CA	K020090			
1UN								1UN			4S-1MA	K020100			
ZBR								ZBR			4S-1UN	K020110			
											4S-ZBR	K020120			
1CA	160	M				E	8F	1CA	04-14	S - 04	4S-1CA	K020130			
1MA								1MA			4S-1MA	K020140			
1UN								1UN			4S-1UN	K020150			
1CA								1CA			4S-1CA	K020160			
1MA	160	M				E	4F	1MA	04-14	S - 04	4S-1MA	K020170			
1UN								1UN			4S-1UN	K020180			

MOTORE 4 POLI 4 POLE MOTOR 1450 rpm			POMPA PUMP	LANTERNA - BELL HOUSING				GIUNTO COMPLETO COMPLETE COUPLING			CODICE KIT KIT CODE			
Kw	TAGLIA SIZE	HP		Ø LANTERNA BELL HOUSING DIAM.	TIPO TYPE	ANELLO DI CENTRAGGIO CENTERING RING	FORATURA HOLES CONFIGURATION	CODICE POMPA PUMP CODE	GIUNTO LATO MOTORE MOTOR SIDE COUPLING	INSERTO ELASTICO SPIDER		GIUNTO LATO POMPA PUMP SIDE COUPLING		
0,55 ÷ 0,75	80	0,75 ÷ 1,0	05U	200	M	S	8F	05U	04-19	S-04	04-05M	K030010		
			1CA					04-05S			K030020			
			1MA					04-1CA			K030030			
			1UN					04-1MA			K030040			
			ZBR					04-1UN			K030050			
			ZBR					04-ZBR			K030060			
			05U	200	M	S	4F	05U	04-19	S-04	04-05M	K030070		
			1CA					04-05S			K030080			
			1MA					04-1CA			K030090			
			1UN					04-1MA			K030100			
			ZBR					04-1UN			K030110			
			ZBR					04-ZBR			K030120			
			1CA	200	M	E	8F	1CA	04-19	S-04	04-1CA	K030130		
			1MA					04-1MA			K030140			
			1UN					04-1UN			K030150			
			1CA	200	M	E	4F	1CA	04-19	S-04	04-1CA	K030160		
			1MA					04-1MA			K030170			
			1UN					04-1UN			K030180			
			2UN	200	M	S	8F	2UN	04-19	S-04	04-2UN	K030190		
			25T					05-3UN			K030191			
			3MA					K030192						
			3TS		K030193									
			3UN		K030194									
			35G		K030195									
			35U		05-35U			K030196						
			35M		K030197									
			ZFR		M			ZFR	04-19	S-04	05-ZFR	K030200		
			ZGR		C			ZGR	05-19	S-05	05-ZGR	K030210		
			ZNR		ZNR			05-ZNR	K030220					
			2UN		M			2UN	04-19	S-04	04-2UN	K030230		
			25T		C			S	4F	25T	05-19	S-05	05-3UN	K030231
			3MA							K030232				
			3TS							K030233				
			3UN	K030234										
			35G	K030235										
			35U	05-35U		K030236								
			35M	K030237										
			ZFR	M		ZFR	04-19			S-04			05-ZFR	K030240
			ZGR	C		ZGR	05-19			S-05			05-ZGR	K030250
			ZNR	ZNR	05-ZNR	K030260								
			2UN	M	2UN	04-19	S-04	04-2UN	K030270					
			25T	C	E	8F	25T	05-19	S-05	05-3UN	K030280			
			3MA				K030290							
			3TS				K030300							
			3UN				K030310							
			35G				K030320							
			35U				05-35U			K030330				
			35M				K030340							
2UN	M	2UN	04-19				S-04			04-2UN	K030350			
25T	C	E	4F				25T			05-19	S-05	05-3UN	K030360	
3MA				K030370										
3TS				K030380										
3UN				K030390										
35G				K030400										
35U				05-35U	K030410									
35M				K030420										

# CODICE KIT KIT CODE

## GR 90

MOTORE 4 POLI 4 POLE MOTOR 1450 rpm			POMPA PUMP	LANTERNA - BELL HOUSING				GIUNTO COMPLETO COMPLETE COUPLING			CODICE KIT KIT CODE						
Kw	TAGLIA SIZE	HP		Ø LANTERNA BELL HOUSING DIAM.	TIPO TYPE	ANELLO DI CENTRAGGIO CENTERING RING	FORATURA HOLES CONFIGURATION	CODICE POMPA PUMP CODE	GIUNTO LATO MOTORE MOTOR SIDE COUPLING	INSERTO ELASTICO SPIDER		GIUNTO LATO POMPA PUMP SIDE COUPLING					
1,1 ÷ 1,5	90	1,5 ÷ 2	05U 1CA 1MA 1UN ZBR 2UN 25T 3MA 3TS 3UN 35G 35U 35M ZFR ZGR ZNR	200	M	S	8F	05U 1CA 1MA 1UN ZBR 2UN 25T 3MA 3TS 3UN 35G 35U 35M	04-24	S-04	04-05M	K040010					
											04-05S	K040020					
											04-1CA	K040030					
											04-1MA	K040040					
											04-1UN	K040050					
											04-ZBR	K040060					
											04-2UN	K040070					
												K040071					
												K040072					
												K040073					
												K040074					
												K040075					
								K040076									
								K040077									
								K040080									
								K040090									
								K040100									
					05U 1CA 1MA 1UN ZBR 2UN 25T 3MA 3TS 3UN 35G 35U 35M ZFR ZGR ZNR			200	M	S	8F	05U 1CA 1MA 1UN ZBR 2UN 25T 3MA 3TS 3UN 35G 35U 35M	04-24	S-04	04-05M	K040108	
															04-05S	K040109	
															04-1CA	K040110	
															04-1MA	K040120	
															04-1UN	K040130	
															04-ZBR	K040140	
															04-2UN	K040150	
				K040151													
				K040152													
				K040153													
				K040154													
				K040155													
				K040156													
				K040157													
				K040160													
				K040170													
				K040180													
			1CA 1MA 1UN 2UN 25T 3MA 3TS 3UN 35G 35U 35M 1CA 1MA 1UN 2UN 25T 3MA 3TS 3UN 35G 35U 35M	200		M	E		4F			1CA 1MA 1UN 2UN 25T 3MA 3TS 3UN 35G 35U 35M	04-24	S-04	04-1CA	K040190	
															04-1MA	K040200	
															04-1UN	K040210	
															04-2UN	K040220	
																K040230	
																K040240	
																K040250	
								K040260									
								K040270									
								K040280									
								K040290									
								K040300									
						K040310											
						K040320											
	K040330																
25T 3MA 3TS 3UN 35G 35U 35M	200	M			E	4F		25T 3MA 3TS 3UN 35G 35U 35M		04-24	S-04	04-1CA	K040300				
												04-1MA	K040310				
												04-1UN	K040320				
												04-2UN	K040330				
													K040340				
													K040350				
		3MA 3TS 3UN 35G 35U 35M						200		C	E	4F	3MA 3TS 3UN 35G 35U 35M	05-24	S-05	05-3UN	K040360
																	K040370
																	K040380
				K040390													
				K040400													
				K040400													

MOTORE 4 POLI 4 POLE MOTOR 1450 rpm			POMPA PUMP	LANTERNA - BELL HOUSING				GIUNTO COMPLETO COMPLETE COUPLING			CODICE KIT KIT CODE	
Kw	TAGLIA SIZE	HP		Ø LANTERNA BELL HOUSING DIAM.	TIPO TYPE	ANELLO DI CENTRAGGIO CENTERING RING	FORATURA HOLES CONFIGURATION	CODICE POMPA PUMP CODE	GIUNTO LATO MOTORE MOTOR SIDE COUPLING	INSERTO ELASTICO SPIDER		GIUNTO LATO POMPA PUMP SIDE COUPLING
2,2 ÷ 3	100	3 ÷ 4	250	M	S	8F	1CA	05-28	S - 05	05-1CA	K050010	
							1MA			05-1MA	K050020	
							1UN			05-1UN	K050030	
							ZBR			05-ZBR	K050040	
							2UN			05-2UN	K050050	
							25T				K050051	
		3MA	05-3UN	K050052								
		3TS		K050053								
		3UN		K050054								
		35G		K050055								
		35U		K050056								
		35M		K050057								
	4	112	5,5	250	M	S	4F	ZFR	05-28	S - 05	05-ZFR	K050060
								ZGR			05-ZGR	K050070
								ZNR			05-ZNR	K050080
								1CA			05-1CA	K050090
								1MA			05-1MA	K050100
								1UN			05-1UN	K050110
		ZBR	05-ZBR	K050120								
		2UN	05-2UN	K050130								
		25T	05-3UN	K050131								
		3MA		K050132								
		3TS		K050133								
		3UN		K050134								
35G	K050135											
35U	K050136											
35M	K050137											
ZFR	05-ZFR	K050140										
ZGR	05-ZGR	K050150										
ZNR	05-ZNR	K050160										
4	112	5,5	250	M	E	8F	1CA	05-28	S - 05	05-1CA	K050170	
							1MA			05-1MA	K050180	
							1UN			05-1UN	K050190	
							2UN			05-2UN	K050200	
							25T				K050210	
							3MA			05-3UN	K050220	
		3TS	K050230									
		3UN	K050240									
		35G	K050250									
		35U	K050260									
		35M	K050270									
		1CA	05-3UN	K050280								
	1MA	K050290										
	1UN	K050300										
	2UN	K050310										
	25T	K050320										
	3MA	K050330										
	3TS	K050340										
	3UN	K050350										
	35G	K050360										
	35U	K050370										
	35M	K050380										



# CODICE KIT KIT CODE

## GR 132

MOTORE 4 POLI 4 POLE MOTOR 1450 rpm			POMPA PUMP	LANTERNA - BELL HOUSING				GIUNTO COMPLETO COMPLETE COUPLING			CODICE KIT KIT CODE			
Kw	TAGLIA SIZE	HP		Ø LANTERNA BELL HOUSING DIAM.	TIPO TYPE	ANELLO DI CENTRAGGIO CENTERING RING	FORATURA HOLES CONFIGURATION	CODICE POMPA PUMP CODE	GIUNTO LATO MOTORE MOTOR SIDE COUPLING	INSERTO ELASTICO SPIDER		GIUNTO LATO POMPA PUMP SIDE COUPLING		
5,5 ÷ 7,5	132	7,5 ÷ 10	2UN	300	M	S	8F	2UN	07-38	S - 07	07-2UN	K060010		
			25T	300				25T			07-3UN	K060020		
			3MA	300				3MA				K060030		
			3TS	300				3TS				K060040		
			3UN	300				3UN				K060050		
			ZFR	300				ZFR				07-ZFR	K060060	
			ZNR	300				ZNR				07-ZNR	K060070	
			35M	300				35M				07-35U	K060080	
			35G	300				35G					K060090	
			35U	300				35U					K060100	
			ZGR	300				ZGR					07-ZGR	K060110
			2UN	300				C					S	4F
			25T	300	25T	07-3UN	K060130							
			3MA	300	3MA		K060140							
			3TS	300	3TS		K060150							
			3UN	300	3UN		K060160							
			ZFR	300	ZFR		07-ZFR		K060170					
			ZNR	300	ZNR		07-ZNR		K060180					
			35M	300	35M		07-35U		K060190					
			35G	300	35G				K060200					
			35U	300	35U				K060210					
			ZGR	300	ZGR				07-ZGR	K060220				
			2UN	300	M				E	8F	2UN	07-38		
			25T	300				25T			07-3UN		K060240	
			3MA	300		3MA		K060250						
			3TS	300		3TS		K060260						
			3UN	300		3UN		K060270						
			///	///		///		///					///	
			///	///		///		///					///	
			35M	300		35M		07-35U					K060300	
			35G	300		35G	K060310							
			35U	300		35U	K060320							
			///	///		///	///						///	
			2UN	300		C	E						4F	2UN
			25T	300	25T				07-3UN	K060350				
			3MA	300	3MA					K060360				
			3TS	300	3TS					K060370				
			3UN	300	3UN					K060380				
			///	///	///					///	///			
			///	///	///					///	///			
			35M	300	35M					07-35U	K060410			
			35G	300	35G			K060420						
			35U	300	35U			K060430						
			///	///	///			///			///			

MOTORE 4 POLI 4 POLE MOTOR 1450 rpm			POMPA PUMP	LANTERNA - BELL HOUSING				GIUNTO COMPLETO COMPLETE COUPLING			CODICE KIT KIT CODE								
Kw	TAGLIA SIZE	HP		Ø LANTERNA BELL HOUSING DIAM.	TIPO TYPE	ANELLO DI CENTRAGGIO CENTERING RING	FORATURA HOLES CONFIGURATION	CODICE POMPA PUMP CODE	GIUNTO LATO MOTORE MOTOR SIDE COUPLING	INSERTO ELASTICO SPIDER		GIUNTO LATO POMPA PUMP SIDE COUPLING							
11 ÷ 15	160	15 ÷ 20	2UN	350	M	S	8F	2UN	10-42	S - 10	10-2UN	K070010							
			25T	350				25T			10-3UN	K070020							
			3MA	350				3MA				K070030							
			3TS	350				3TS				K070040							
			3UN	350				3UN				K070050							
			ZFR	350				ZFR				10-ZFR	K070060						
			ZNR	350				ZNR				10-ZNR	K070070						
			ZGR	350				ZGR				10-ZGR	K070080						
			35G	350				35G				10-35U	K070081						
			35U	350				35U					K070082						
			35M	350				35M					K070083						
			4MA	350				4MA					10-4UN	K070084					
			4TS	350	4TS	K070085													
			4UN	350	4UN	K070086													
			2UN	350	M	S	4F	2UN	10-42	S - 10	10-2UN			K070090					
			25T	350				25T			10-3UN			K070100					
			3MA	350				3MA						K070110					
			3TS	350				3TS					K070120						
			3UN	350				3UN					K070130						
			ZFR	350				ZFR					10-ZFR	K070140					
			ZNR	350				ZNR				10-ZNR	K070150						
			ZGR	350				ZGR				10-ZGR	K070160						
			35G	350				35G				10-35U	K070161						
			35U	350				35U					K070162						
			35M	350				35M					K070163						
			4MA	350				4MA					10-4UN	K070164					
			4TS	350	4TS	K070165													
			4UN	350	4UN	K070166													
			25T	350	M	E	8F	25T	10-42	S - 10	10-3UN	K070170							
			3MA	350				3MA				K070180							
			3TS	350				3TS				K070190							
			3UN	350				3UN				K070200							
			35G	350				35G				10-35U	K070210						
			35U	350				35U					K070220						
			35M	350				35M					K070230						
			4MA	350				4MA					10-4UN	K070240					
			4TS	350				4TS						K070250					
			4UN	350				4UN						K070260					
			25T	350				M				E		4F	25T	10-42	S - 10	10-3UN	K070270
			3MA	350											3MA				K070280
			3TS	350	3TS	K070290													
			3UN	350	3UN	K070300													
			35G	350	35G	10-35U	K070310												
			35U	350	35U		K070320												
			35M	350	35M		K070330												
			4MA	350	4MA		10-4UN		K070340										
			4TS	350	4TS				K070350										
			4UN	350	4UN				K070360										

MOTORE 4 POLI 4 POLE MOTOR 1450 rpm			POMPA PUMP	LANTERNA - BELL HOUSING				GIUNTO COMPLETO COMPLETE COUPLING			CODICE KIT KIT CODE							
Kw	TAGLIA SIZE	HP		Ø LANTERNA BELL HOUSING DIAM.	TIPO TYPE	ANELLO DI CENTRAGGIO CENTERING RING	FORATURA HOLES CONFIGURATION	CODICE POMPA PUMP CODE	GIUNTO LATO MOTORE MOTOR SIDE COUPLING	INSERTO ELASTICO SPIDER		GIUNTO LATO POMPA PUMP SIDE COUPLING						
18,5 ÷ 22	180	25 ÷ 30	2UN	350	M	S	8F	2UN	10-48	S - 10	10-2UN	K080010						
			25T	350				25T			K080020							
			3MA	350				3MA			10-3UN	K080030						
			3TS	350				3TS			K080040							
			3UN	350				3UN			K080050							
			ZFR	350				ZFR			10-ZFR	K080060						
			ZNR	350				ZNR			10-ZNR	K080070						
			ZGR	350				ZGR			10-ZGR	K080080						
			35M	350	35M		K080081											
			35G	350	35G		10-35U	K080082										
			35U	350	35U		K080083											
			4MA	350	4MA		K080084											
			4TS	350	4TS		10-4UN	K080085										
			4UN	350	4UN		K080086											
			2UN	350	M		2UN	S			4F	2UN	10-48	S - 10	10-2UN	K080090		
			25T	350			25T					K080100						
			3MA	350		3MA	10-3UN			K080110								
			3TS	350		3TS	K080120											
			3UN	350		3UN	K080130											
			ZFR	350		ZFR	10-ZFR			K080140								
			ZNR	350		ZNR	10-ZNR			K080150								
			ZGR	350		ZGR	10-ZGR			K080160								
			35M	350	35M	K080161												
			35G	350	35G	10-35U	K080162											
			35U	350	35U	K080163												
			4MA	350	4MA	K080164												
			4TS	350	4TS	10-4UN	K080165											
			4UN	350	4UN	K080166												
			25T	350	M	25T	E			8F	25T	10-48			S - 10	10-3UN	K080170	
			3MA	350		3MA					K080180							
			3TS	350		3TS		10-3UN			K080190							
			3UN	350		3UN		K080200										
			35M	350		35M		10-35U			K080210							
			35G	350		35G		K080220										
			35U	350		35U		K080230										
			4MA	350		4MA		K080240										
			4TS	350	4TS	10-4UN		K080250										
			4UN	350	4UN	K080260												
			25T	350	M	25T		E		4F	25T			10-48		S - 10	10-3UN	K080270
			3MA	350		3MA					K080280							
			3TS	350		3TS					10-3UN						K080290	
			3UN	350		3UN					K080300							
			35M	350		35M					10-35U						K080310	
			35G	350		35G					K080320							
			35U	350		35U	K080330											
			4MA	350		4MA	K080340											
			4TS	350	4TS	10-4UN	K080350											
			4UN	350	4UN	K080360												

MOTORE 4 POLI 4 POLE MOTOR 1450 rpm			POMPA PUMP	LANterna - BELL HOUSING				GIUNTO COMPLETO COMPLETE COUPLING			CODICE KIT KIT CODE						
Kw	TAGLIA SIZE	HP		Ø LANterna BELL HOUSING DIAM.	TIPO TYPE	ANELLO DI CENTRAGGIO CENTERING RING	FORATURA HOLES CONFIGURATION	CODICE POMPA PUMP CODE	GIUNTO LATO MOTORE MOTOR SIDE COUPLING	INSERTO ELASTICO SPIDER		GIUNTO LATO POMPA PUMP SIDE COUPLING					
30	200	40	25T	400	C	S	8F	25T	10-55	S - 10	10-3UN	K090010					
			3MA	400				3MA				K090020					
			3TS	400				3TS				K090030					
			3UN	400				3UN				K090040					
			ZNR	400				ZNR				K090050					
			ZGR	400				ZGR				K090060					
			35M	400				35M			K090070						
			35G	400				35G			K090080						
			35U	400				35U			K090090						
			4MA	400				4MA			K090100						
			4TS	400				4TS			K090110						
			4UN	400				4UN			K090120						
			25T	400	C	S	4F	25T	10-55	S - 10	10-3UN	K090130					
			3MA	400				3MA				K090140					
			3TS	400				3TS				K090150					
			3UN	400				3UN				K090160					
			ZNR	400				ZNR				K090170					
			ZGR	400				ZGR				K090180					
			35M	400				35M			K090190						
			35G	400				35G			K090200						
			35U	400				35U			K090210						
			4MA	400				4MA			K090220						
			4TS	400				4TS			K090230						
			4UN	400				4UN			K090240						
			25T	400	C	E	8F	25T	10-55	S - 10	10-3UN	K090250					
			3MA	400				3MA				K090260					
			3TS	400				3TS				K090270					
			3UN	400				3UN				K090280					
			35M	400				35M				K090290					
			35G	400				35G				K090300					
			35U	400				35U			K090310						
			4MA	400				4MA			K090320						
			4TS	400				4TS			K090330						
			4UN	400				4UN			K090340						
			25T	400				C			E	4F	25T	10-55	S - 10	10-3UN	K090350
			3MA	400									3MA				K090360
			3TS	400	3TS	K090370											
			3UN	400	3UN	K090380											
			35M	400	35M	K090390											
			35G	400	35G	K090400											
			35U	400	35U	K090410											
			4MA	400	4MA	K090420											
			4TS	400	4TS	K090430											
			4UN	400	4UN	K090440											

# CODICE KIT KIT CODE

## GR 225

MOTORE 4 POLI 4 POLE MOTOR 1450 rpm			POMPA PUMP	LANTERNA - BELL HOUSING				GIUNTO COMPLETO COMPLETE COUPLING			CODICE KIT KIT CODE							
Kw	TAGLIA SIZE	HP		Ø LANTERNA BELL HOUSING DIAM.	TIPO TYPE	ANELLO DI CENTRAGGIO CENTERING RING	FORATURA HOLES CONFIGURATION	CODICE POMPA PUMP CODE	GIUNTO LATO MOTORE MOTOR SIDE COUPLING	INSERTO ELASTICO SPIDER		GIUNTO LATO POMPA PUMP SIDE COUPLING						
37 ÷ 45	225	50 ÷ 60	25T	450	C	S	8F	25T	10-60	S - 10	10-3UN	K100010						
			3MA	450				3MA				K100020						
			3TS	450				3TS				K100030						
			3UN	450				3UN				K100040						
			ZNR	450				ZNR				K100050						
			ZGR	450				ZGR				K100060						
			35M	450				35M				K100070						
			35G	450				35G				K100080						
			35U	450				35U				K100090						
			4MA	450				4MA				K100100						
			4TS	450				4TS				K100110						
			4UN	450				4UN				K100120						
			25T	450				C				S	4F	25T	10-60	S - 10	10-3UN	K100130
			3MA	450										3MA				K100140
			3TS	450										3TS				K100150
			3UN	450	3UN	K100160												
			ZNR	450	ZNR	K100170												
			ZGR	450	ZGR	K100180												
			35M	450	35M	K100190												
			35G	450	35G	K100200												
			35U	450	35U	K100210												
			4MA	450	4MA	K100220												
			4TS	450	4TS	K100230												
			4UN	450	4UN	K100240												
			25T	450	C	E	8F		25T	10-60	S - 10			10-3UN				K100250
			3MA	450					3MA									K100260
			3TS	450					3TS									K100270
			3UN	450				3UN	K100280									
			35M	450				35M	K100290									
			35G	450				35G	K100300									
			35U	450				35U	K100310									
			4MA	450				4MA	K100320									
			4TS	450				4TS	K100330									
			4UN	450				4UN	K100340									
			25T	450				C	E			4F	25T		10-60	S - 10	10-3UN	K100350
			3MA	450									3MA					K100360
			3TS	450									3TS					K100370
			3UN	450									3UN					K100380
			35M	450									35M					K100390
			35G	450	35G	K100400												
			35U	450	35U	K100410												
			4MA	450	4MA	K100420												
			4TS	450	4TS	K100430												
			4UN	450	4UN	K100440												

# RACCORDO POMPA DIRITTO STRAIGHT PUMP CONNECTOR

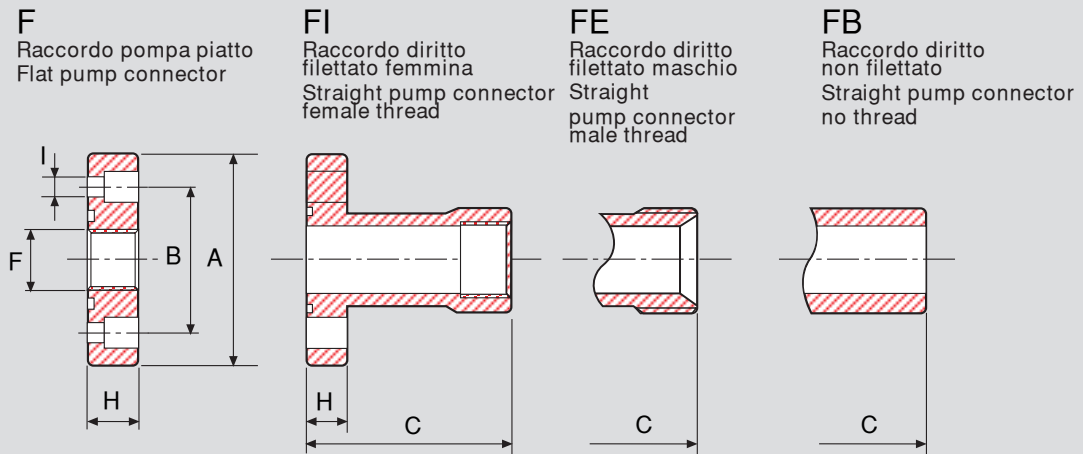

RACCORDO CONNECTOR	POMPA PUMP	DIMENSIONI / DIMENSIONS									FORI HOLES N°	VITI SCREWS	O-RING
		A	B	C	D	E	F	H	I				
<b>F 1</b>	1	45	30	/	/	/	3/8"	13	6,5	4	M 6 X 16	2075	
<b>FI 1</b>	1	45	30	55	21	/	3/8"	10	6,5	4	M 6 X 20	2075	
<b>FE 1</b>	1	45	30	55	/	14	1/2"	10	6,5	4	M 6 X 21	2075	
<b>FB 1</b>	1	45	30	55	19	14	/	10	6,5	4	M 6 X 22	2075	
<b>F 2</b>	2	58	40	/	/	/	1/2"	15	8,5	4	M 8 X 20	2100	
<b>FI 2</b>	2	58	40	60	26,5	/	1/2"	12	8,5	4	M 8 X 25	2100	
<b>FE 2</b>	2	58	40	60	/	19	3/4"	12	8,5	4	M 8 X 25	2100	
<b>FB 2</b>	2	58	40	60	25,4	19	/	12	8,5	4	M 8 X 25	2100	
<b>F 3/A</b>	3/A	75	51	/	/	/	3/4"	18	10,5	4	M10 X 25	3125	
<b>FI 3/A</b>	3/A	76	51	72	33,5	/	3/4"	16	10,5	4	M10 X 35	3125	
<b>FE 3/A</b>	3/A	76	51	72	/	24	1"	16	10,5	4	M10 X 35	3125	
<b>FB 3/A</b>	3/A	76	51	72	32	24,5	/	16	10,5	4	M10 X 35	3125	
<b>F 3/B</b>	3/B	75	56	/	/	/	3/4"	18	10,5	4	M10 X 25	3125	
<b>FI 3/B</b>	3/B	76	56	72	33,5	/	3/4"	16	10,5	4	M10 X 35	3125	
<b>FE 3/B</b>	3/B	76	56	72	/	24	1"	16	10,5	4	M10 X 35	3125	
<b>FB 3/B</b>	3/B	76	56	72	32	24,5	/	16	10,5	4	M10 X 35	3125	
<b>F 3,5/A</b>	3,5/A	88	62	/	/	/	1"	20	10,5	4	M10 X 25	144	
<b>F 3,5/B</b>	3,5/B	88	62	/	/	/	1"	20	12,5	4	M12 X 25	144	
<b>F 4</b>	4	98	72,5	/	/	/	1"1/4	22	12,5	4	M12 X 30	4187	

Costruiti in acciaio, permettono di collegare tubi di aspirazione o mandata sulle pompe oleodinamiche evitando perdite di carico dovute a raccordi a gomito. Sono forniti completi di viti, rondelle ed O-ring.

Made of steel, they allow the connection between rigid pipe and inlet or outlet ports of hydraulic pumps. They are supplied complete with screws, washers and o-ring.

# RACCORDO POMPA A 90° A 3 FORI IN ACCIAIO

## STEEL 90°PUMP CONNECTOR WITH 3 HOLES

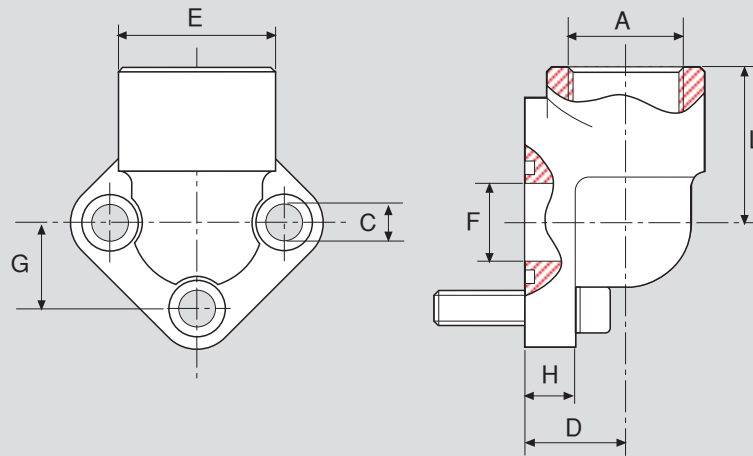

RACCORDO CONNECTOR	POMPA PUMP	DIMENSIONI / DIMENSIONS											
		B	G	C	E	A	L	F	H	FORI / HOLES N°	VITI SCREWS	O-RING	
RPA 0,5 / 38	0,5	26	13	5,5	30	3/8"	31	11	9	17	3	M 5 X 18	2056
RPA 0,5 / 12						1/2"							
RPA 1 / 38	1	30	15	6,5	30	3/8"	31	12	9	17	3	M 6 X 20	121
RPA 1 / 12						1/2"							
RPA 2 / 12	2	40	20	8,5	36	1/2"	36	19	11,5	23	3	M 8 X 25	132
RPA 2 / 34						3/4"							
RPA 3 / 34 / A	3 / A	51	25,5	10,5	45	3/4"	46	24	13	26	3	M10 X 30	4118
RPA 3 / 100 / A						1"							
RPA 3 / 34 / B	3 / B	56	28	10,5	45	3/4"	46	24	13	26	3	M10 X 30	4118
RPA 3 / 100 / B						1"							
RPA 3,5 / 114 / A	3,5 / A	62	31	11	55	1" 1/4	55	31	14	35	3	M10 X 30	4150
RPA 3,5 / 100 / A						1"		25					
RPA 3,5 / 114 / B	3,5 / B	62	31	13	55	1" 1/4	55	31	14	35	3	M12 X 35	4150
RPA 3,5 / 100 / B						1"		25					
RPA 4 / 112	4	72,5	36,2	13	62	1" 1/2	58	38	15	38	3	M12 X 35	4187
RPA 4 / 114						1" 1/4		31					

Costruiti in acciaio, sono adatti per il montaggio su motori e pompe oleodinamiche.

A richiesta si possono eseguire anche a saldare, filettati DIN o secondo specifica del cliente.

Made of steel, they are able to be mounted on hydraulic pump and motor. They can be supplied with other connections (DIN, Socket weld ...) or according to customer specifications.

### CODICE D'ORDINE / ORDERING EXAMPLE

RPA... = Solo flangia / Only connector

RPA... M = Raccordo completo di viti, rondelle ed O-ring / Complete connector with screws, washers and o-ring.

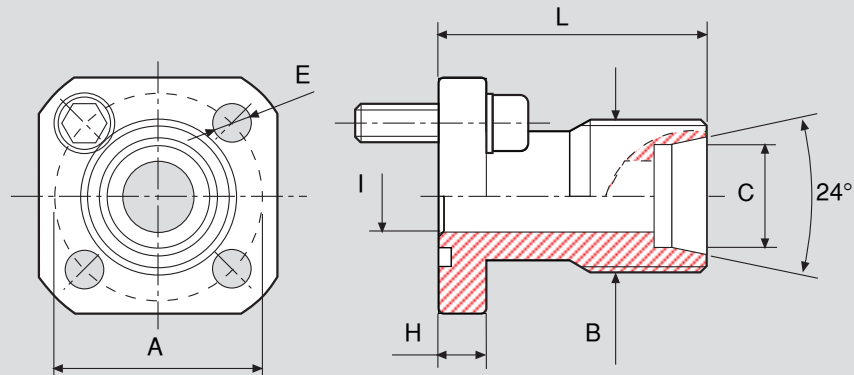

RACCORDO CONNECTOR	DIMENSIONI / DIMENSIONS									
	A	B	C	E	H	I	L	VITI / SCREWS	O-RING	
RD 35 10L	35	M16 X 1,5	10	6,5	8	8	30	M 6 X 20	3075	
RD 35 12L		M18 X 1,5	12			10				
RD 35 15L		M22 X 1,5	15			12				
RD 35 16S		M24 X 1,5	16			12				
RD 40 15L	40	M22 X 1,5	15	6,5	8	12	35	M 6 X 20	3100	
RD 40 18L		M26 X 1,5	18			15				
RD 40 22L		M30 X 2	22			19				40
RD 40 28L		M36 X 2	28			19				40
RD 40 20S		M30 X 2	20			16				35
RD 55 20S	55	M30 X 2	20	8,5	12	16	50	M 8 X 25	3125	
RD 55 25S		M36 X 2	25			20				
RD 55 30S		M42 X 2	30			26				
RD 55 35L		M45 X 2	35			26				

Costruiti in acciaio, vengono forniti completi di viti, rondelle ed O-ring. Sono adatti per il montaggio su motori e pompe oleodinamiche. A richiesta si possono eseguire secondo specifica del cliente.

Made of steel, they are able to be mounted on hydraulic pump and motor. They can be supplied according to customer specification.

**CODICE D'ORDINE / ORDERING EXAMPLE**

RD...M = Raccordo completo di viti, rondelle ed O-ring / Complete connector with screws, washers and o-ring.



# RACCORDO POMPA A 90° FILETTATO DIN 2353

## 90° STEEL PUMP CONNECTOR DIN 2353 THREAD

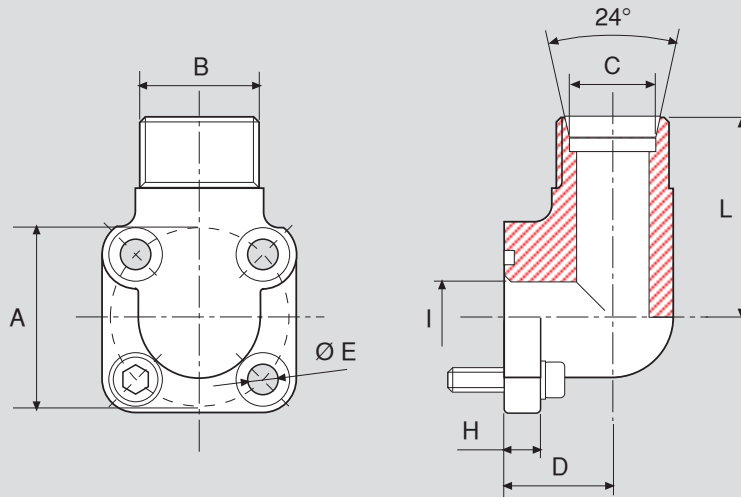

RACCORDO CONNECTOR	DIMENSIONI DIMENSIONS											
	A	B	C	D	E	H	I	L	N° 2 VITI N° 2 SCREWS	N° 2 VITI N° 2 SCREWS	O-RING	
R 35 10L 90	35	M16 X 1,5	10	16,5	6,5	8	8	38	M 6 X 20	M 6 X 35	3075	
R 35 12L 90		M18 X 1,5	12				10					
R 35 15L 90		M22 X 1,5	15	12			M 6 X 40					
R 35 16S 90		M24 X 1,5	16	20						40		
R 40 15L 90	40	M22 X 1,5	15	22,5	6,5	8	12	M 6 X 20	M 6 X 40	3100		
R 40 18L 90		M26 X 1,5	18				15				38	
R 40 22L 90		M30 X 2	22	28			18		40		M 6 X 50	
R 40 28L 90		M36 X 2	28				16					M 6 X 40
R 40 20S 90		M30 X 2	20	22,5			16		M 6 X 40			
R 55 35L 90	55	M45 X 2	35	31	8,5	12	26	49	M 8 X 25	M 8 X 60	3125	
R 55 20S 90		M30 X 2	20	24			16			46		M 8 X 45
R 55 25S 90		M36 X 2	25	31			20			49		M 8 X 60
R 55 30S 90		M42 X 2	30									
R 55 42L 90		M52 X 2	42	40			26			49		M 8 X 70
R 55 38S 90		M52 X 2	38									

Costruiti in acciaio, vengono forniti completi di viti, rondelle ed O-ring. Sono adatti per il montaggio su motori e pompe oleodinamiche.

A richiesta si possono eseguire secondo specifica del cliente.

Made of steel, they are able to be mounted on hydraulic pump and motor. They can be supplied according to customer specification.

#### CODICE D'ORDINE / ORDERING EXAMPLE

R...90M = Raccordo completo di viti, rondelle ed O-ring / Connector with screws, washers and o-ring.

**Tipo < E >**  
**FILETTATO GAS MASCHIO**  
**< E > Type**  
**BSP MALE**

**Tipo < I >**  
**FILETTATO GAS FEMMINA**  
**< I > Type**  
**BSP FEMALE**

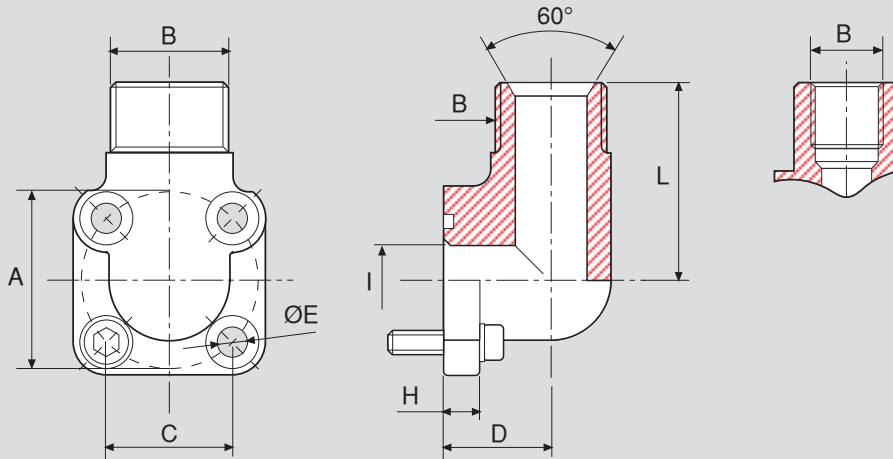

RACCORDO CONNECTOR	DIMENSIONI / DIMENSIONS											
	A	B	C	D	E	H	I	L	N° 2 VITI N° 2 SCREWS	N° 2 VITI N° 2 SCREWS	O-RING	
R 35 90 3/8"	35	3/8"	24,8	16,5	6,5	8	10	38	M 6 X 20	M 6 X 35	3075	
R 35 90 1/2"		1/2"		16,5			12					
R 35 90 3/4" *		3/4"		20			15					40
R 40 90 3/8"	40	3/8"	28,2	22,5	6,5	8	10	38	M 6 X 20	M 6 X 40	3100	
R 40 90 1/2"		1/2"					12					
R 40 90 3/4"		3/4"					17					
R 40 90 1" *		1"		19			40					M 6 X 50
R 55 90 1/2"	55	1/2"	38,8	24	8,5	12	12	49	M 8 X 25	M 8 X 45	3125	
R 55 90 3/4"		3/4"		31			17			46		M 8 X 60
R 55 90 1"		1"		31			22			49		M 8 X 70

\* = Disponibile solo tipo "E" / available only on type "E"

Costruiti in acciaio, vengono forniti completi di viti, rondelle ed O-ring. Sono adatti per il montaggio su motori e pompe oleodinamiche. A richiesta si possono eseguire secondo specifica del cliente.  
Made of steel, they are able to be mounted on hydraulic pump and motor. They can be supplied according to customer specification.

#### CODICE D'ORDINE / ORDERING EXAMPLE

R...90...I M = Raccordo filettato femmina completo di viti, rondelle ed OR / Female thread complete connector with screws, washers and o-ring

R...90...E M = Raccordo completo di viti, rondelle ed O-ring / Male thread complete connector complet with screws, washers and o-ring

# RACCORDO POMPA A 90° A 4 FORI IN ALLUMINIO ALUMINIUM 90° PUMP CONNECTOR 4 HOLES

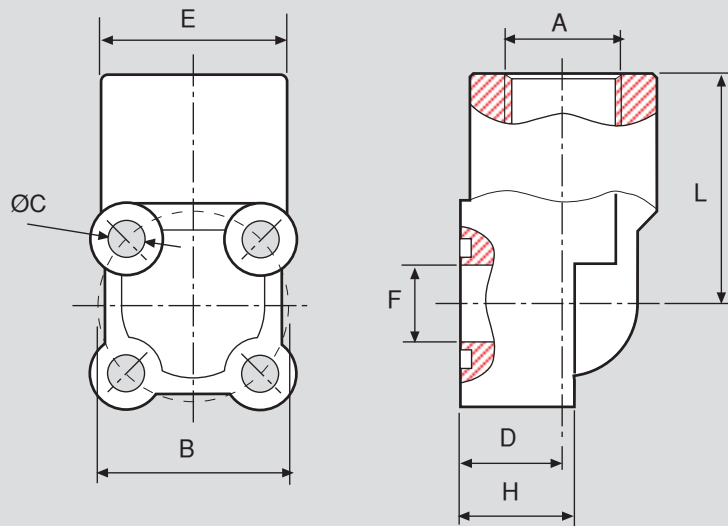

RACCORDO CONNECTOR	DIMENSIONI / DIMENSIONS												
	TAGLIA SIZE	A	B	C	D	E	F	H	L	FORI / HOLES N°	N° 2 VITI N° 2 SCREWS	N° 2 VITI N° 2 SCREWS	O-RING
RPB 38 30	30	3/8"	30	6,5	18	33	11,5	20	39	4	M 6 X 30	M 6 X 40	121
RPB 12 30		1/2"											
RPB 38 35	35	3/8"	35	6,5	18	34	14	20	42,5	4	M 6 X 30	M 6 X 40	3075
RPB 12 35		1/2"											
RPB 12 40	40	1/2"	40	6,5	24	41	18	28	47,5	4	M 6 X 40	M 6 X 50	130
RPB 34 40		3/4"											
RPB 34 55	55	3/4"	55	8,5	29	49	24,5	31	54	4	M 8 X 45	M 8 X 60	4118
RPB 100 55		1"											

Costruiti in alluminio, vengono forniti completi di viti, rondelle ed O-ring. Sono adatti per il montaggio su motori e pompe oleodinamiche.

Made of aluminium, they are able to be mounted on hydraulic pumps and motor. They are supplied complete with screws, washers and o-ring.

#### CODICE D'ORDINE / ORDERING EXAMPLE

RPB...M = Raccordo completo di viti, rondelle ed O-ring / Complete connector with screws, washers and o-ring

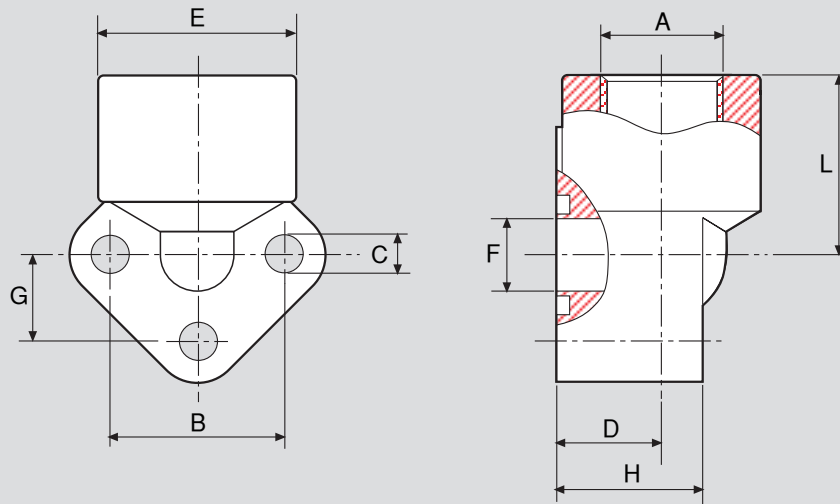

RACCORDO CONNECTOR	DIMENSIONI / DIMENSIONS												
	TAGLIA SIZE	A	B	C	D	E	F	G	H	L	FORI / HOLES N°	N° 2 VITI N° 2 SCREWS	O-RING
RAP 05 38	0,5	3/8"	26	5,5	18	31	10	13	25	31	3	M 5 X 35	2056
RAP 05 12		1/2"											
RAP 1 38	1	3/8"	30	6,5	18	34	12,5	15	26	31	3	M 6 X 35	121
RAP 1 12		1/2"											
RAP 2 12	2	1/2"	40	8,5	21,5	42	18	20	31	40	3	M 8 X 45	130
RAP 2 34		3/4"											
RAP 3 34	3	3/4"	51-56	11	26	49	24,5	25,5-28	42	46	3	M10 X 60	4118
RAP 3 100		1"											

Costruiti in alluminio, vengono forniti completi di viti, rondelle ed O-ring. Sono adatti per il montaggio su motori e pompe oleodinamiche.

Made of aluminium, they are able to be mounted on hydraulic pumps and motor. They are supplied complete with screws, washers and o-ring.

#### CODICE D'ORDINE / ORDERING EXAMPLE

RAP...M = Raccordo completo di viti, rondelle ed O-ring / Complete connector with screws, washers and o-ring.

# RACCORDO A 90° A SALDARE DI TASCA

## 90° SOCKET WELD CONNECTOR

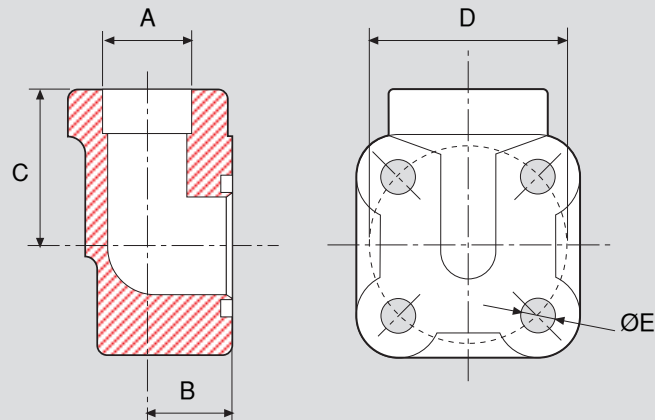

RACCORDO CONNECTOR	DIMENSIONI / DIMENSIONS						
	A	B	C	D	E	VITI / SCREWS	O-RING
F 30 12 90 SA	12	13	27	30	6,5	M 6 X 30	121
F 30 14 90 SA	14						
F 30 16 90 SA	16						
F 30 18 90 SA	18						
F 35 14 90 SA	14	14	30	35	6,5	M 6 X 35	3075
F 35 16 90 SA	16						
F 35 18 90 SA	18						
F 35 20 90 SA	20						
F 40 18 90 SA	18	17	32	40	6,5	M 6 X 40	132
F 40 20 90 SA	20						
F 40 22 90 SA	22						
F 40 25 90 SA	25						

RACCORDO CONNECTOR	DIMENSIONI / DIMENSIONS						
	A	B	C	D	E	VITI / SCREWS	O-RING
F 30 12 90 SB	12	13	27	30	8,5	M 8 X 35	121
F 30 14 90 SB	14						
F 30 16 90 SB	16						
F 35 14 90 SB	14	14	30	35	8,5	M 8 X 40	3075
F 35 16 90 SB	16						
F 35 18 90 SB	18						
F 40 18 90 SB	18	17	32	40	8,5	M 8 X 40	132
F 40 20 90 SB	20						
F 40 22 90 SB	22						
F 40 25 90 SB	25						

Costruiti in acciaio a richiesta si possono eseguire secondo specifica del cliente.  
Made of steel, on request they can be supplied according to customer specification.

#### CODICE D'ORDINE / ORDERING EXAMPLE

F...A = Raccordo per viti M6 / Connector for M6 screws

F...B = Raccordo per viti M8 / Connector for M8 screws

La SETCO s.r.l. fa il suo esordio sulla scena industriale nel 2004, formata da uno staff tecnico-dirigenziale che vanta una pluriennale esperienza maturata nel segmento merceologico in cui opera.

Basata sulla potenzialità dei singoli, perciò sul valore umano, si avvale di personale altamente qualificato che agisce al meglio, secondo le direttive aziendali, non disdegnando l'impiego delle più moderne attrezzature di cui dispone. Grazie all'esperienza dell'azienda nella progettazione, l'alta capacità tecnologica delle attrezzature utilizzate dai reparti produttivi, la SETCO è già in grado di produrre una vasta gamma di prodotti che nell'insieme costituiscono la componentistica per l'assemblaggio di centrali ed impianti oleodinamici fra cui lanterne, giunti elastici, piedini per accoppiamenti motore-pompa e raccordi per pompe, flange sae e valvole a sfera per alta pressione particolarmente indicati per trasmissioni oleodinamiche. Sia la progettazione che la produzione sono sempre in fermento, destinate ad essere ampliate nel volgere di breve tempo e tali da coprire e far fronte alle più svariate richieste di mercato.

In particolare, i giunti elastici utilizzati per la trasmissione del moto delle pompe sono studiati secondo un design particolare, che permette loro un esercizio intrinsecamente più equilibrato di quelli proposti dalla concorrenza. Vengono prodotti in pressofusione di alluminio, assemblati con l'interposizione di un elemento ammortizzante che separa, evitando il diretto contatto dei denti, ciascun semigiunto.

Peculiarità di questi giunti è che a parità di diametro trasmettono il 25% di potenza in più rispetto ai corrispondenti di altra marca; questo grazie alle ridotte dimensioni e all'aumentato raggio di azione della forza tangenziale agente sui denti, perciò, a parità di potenza trasmessa, la loro durata (vita) è notevolmente superiore, la quale determina una diminuzione dei costi di gestione della trasmissione.

La serie dei giunti è stata sottoposta a test di cedimento strutturale (distruzione) e di durata a fatica (collasso del materiale) in collaborazione con il "Politecnico di Milano - Dipartimento di Meccanica" che ne ha certificato i collaudi dando risultati di gran lunga superiori alle torsioni a cui sono normalmente sottoposti.

L'azienda è concepita e strutturata per avere la massima flessibilità dei suoi reparti, è in grado di rispondere con estrema rapidità alle più svariate problematiche ed esigenze particolari dei singoli clienti sia dal punto di vista tecnico che produttivo, offrendo un servizio che oggi poche aziende sono in grado di espletare. Un occhio particolare è riservato alla efficienza operativa, alla pronta risposta dello staff commerciale ed a un reparto spedizioni in grado di rispondere alle sempre più frequenti richieste urgenti e "just in time" della clientela, fanno sì che vengano soddisfatte in tempi brevi le richieste della clientela con loro piena soddisfazione. La SETCO, commercialmente, si avvale di una rete di vendita che ricopre sia il territorio nazionale che estero nell'ambito europeo e asiatico, curando un servizio ed una assistenza tecnico/commerciale di completa soddisfazione del cliente.

SETCO S.r.l. started their activity on the industrial scene in 2004, formed by a staff of managers and technicians with many year of experience in the branch they're working in.

Based on individuals' potentiality, therefore on the human value, they avail themselves of highly qualified personnel who acts at his best, according to the company guidelines, profiting by the most advanced technologies they've got at their disposal.

Thanks to the company's experience in design as well to the high technological capacity of the equipments used by the production departments, SETCO is already able to manufacture a wide range of products, that on the whole make up the components for the assembly of oleohydraulic power pack and plants: bell-housing, drive couplings, feet flange, to couple motors and pump, pump connectors, SAE flanges, high pressure ball valves particularly fit for oleohydraulic transmissions.

Both design and production departments are always in full activity and are aimed at being enlarged in the course of a short time, in order to fulfil and face the most different market's requests.

In particular, the drive couplings used for the transmission of the motion of pumps are studied according to a specific design, allowing them an intrinsically more balanced operation than the one proposed by the competitors.

They're manufactured by aluminium diecasting and assembled by the interposition of a shock-absorbing element which separates, by avoiding the direct contact of the teeth, each half-coupling.

The special feature of these coupling is that, diameter being equal, they transmit 25% more power in comparison with the correspondents of other makes; this is possible thanks to the reduced dimensions as well as to the increased range of the tangential force acting on the teeth, therefore, the transmitted power being equal, their duration (life) is substantially longer, this involving a reduction of costs in the management of the transmission.

The series of couplings underwent a structural yielding (destruction) and fatigue life test (material collapse) in cooperation with the "Politecnico di Milano - Dipartimento di Meccanica" ("Milan University - Department of Mechanics"), which certified the tests with results much higher than the torsional stresses they're normally submitted to.

The Company is conceived and structured to have the greatest flexibility in its departments and is able to react very rapidly to the most different problems and specific needs of each customer, both on the technical and production side, by offering a service that nowadays only a few company are able to supply.

A particular attention is dedicated to the operating efficiency, to the prompt reaction of the commercial staff and to a shipping department ready to respond to the more and more frequent urgent and just-in-time requests of the customers; all this enables the Company to fulfil customers' needs promptly with their full satisfaction.

From the commercial point of view, SETCO avail themselves of a sales net covering both the domestic and foreign (Europe and Asia) markets, implementing a service and a technical commercial assistance to customers' full satisfaction.





Setco srl  
Via Treviglio, 44 - Brignano G. d'Adda (BG)-I  
Tel. +39 0363 817058 - Fax +39 0363 383661  
[www.setco.it](http://www.setco.it) - [info@setco.it](mailto:info@setco.it)