



FA5 SERIES

In line medium pressure filters

Inline filters with spin-on cartridge for operating pressure up to 24 bar, flow rate up to 250 l/min.

The indicator ports allow to fit a visual electrical differential indicator and an absolute clock manometer or pressure switch.

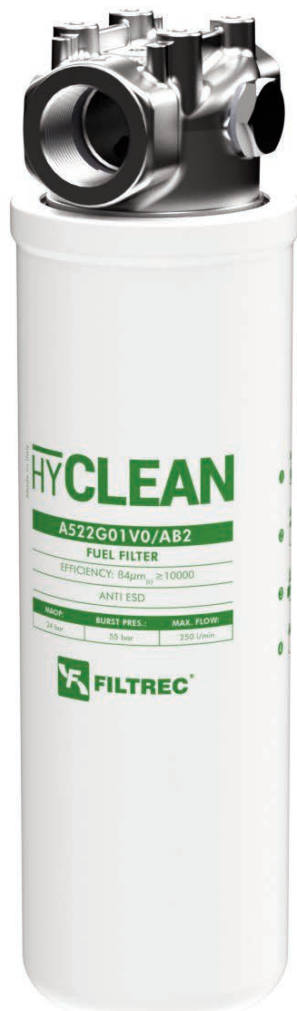

HOUSING	tested according to NFPA T3.10.17, ISO12829, ISO3968
PRESSURE:	Max operating: 24 bar Burst: 55 bar
CONNECTION:	G 1 1/4"
MATERIALS:	Head: aluminium alloy Bowl: painted steel Seal: FKM
BYPASS VALVE:	No by-pass
ELEMENT	tested according to ISO 11170, 2941, 2942, 2943, 3724, 3968, 16889, 16908, 23181
FILTER MEDIA:	Inorganic microfiber: G01 - G03 - G06 - G10 - G25 Inorganic microfiber + water absorbent: GW40
COLLAPSE PRESSURE:	12 bar
TEMPERATURE RANGE:	from -25 °C to +120 °C
FLUID COMPATIBILITY:	Full with HH-HL-HM-HV HETG-HEES (acc. to ISO 6743/4). Diesel EN590, ASTM D975 Biodiesel B0 to B100 EN14214 Fuel oil EN51603-1 For use with other fluid please contact Filtrac Customer Service (info@filtrac.it).

OVERALL DIMENSIONS

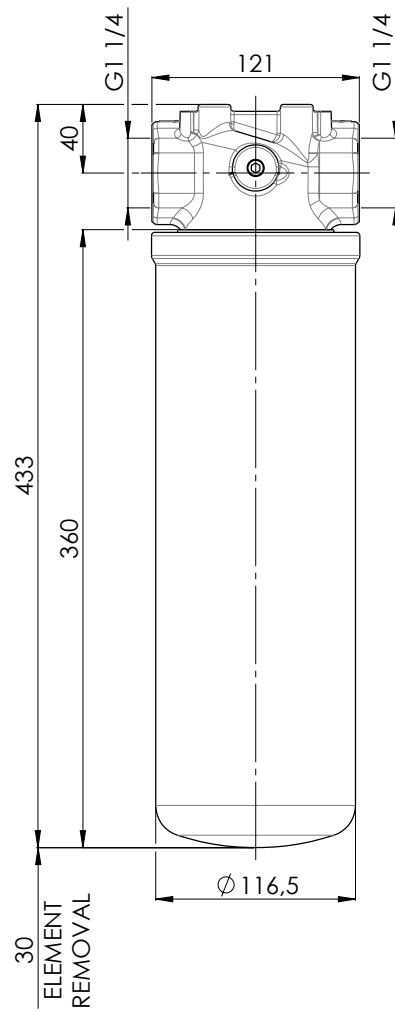

Weight: 3,9Kg

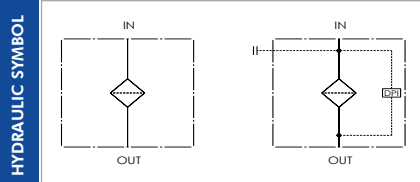
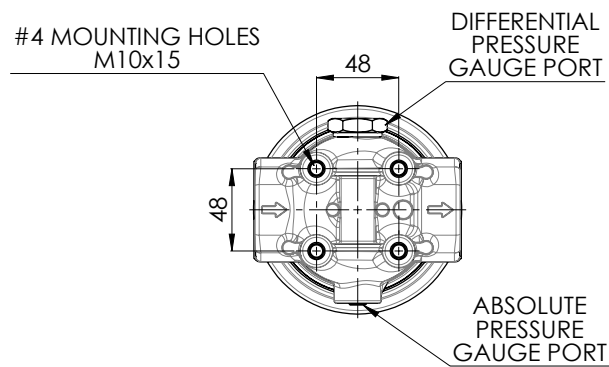

ORDERING INFORMATION

	1.	2.	3.	4.	5.	6.	7.	8.	9.	10.	11.	12.	13.
	FA5	22	G01	V	0	AB2	B6	0	Z	000	S	0	
SPARE ELEMENT	A5	22	G01	V	0	/AB2							

1. FILTER SERIES	FA5	
2. FILTER ELEMENT SERIES	A5	
3. FILTER SIZE	22	
4. FILTER MEDIA	000	no element
	G01	glassfiber $\beta_{4\mu\text{m(c)}} > 10.000$
	G03	glassfiber $\beta_{5\mu\text{m(c)}} > 5.000$
	G06	glassfiber $\beta_{7\mu\text{m(c)}} > 2.000$
	G10	glassfiber $\beta_{10\mu\text{m(c)}} > 2.000$
	G25	glassfiber $\beta_{25\mu\text{m(c)}} > 2.000$
	GW40	glassfiber $\beta_{35\mu\text{m(c)}} > 1.000$ + water absorbent
5. SEALS	V	FKM
6. BYPASS VALVE	0	no by-pass (element inbuilt)
7. ELEMENT SUFFIX	AB2	AbsoluteBeta 2 - very high capacity / efficiency filter element
8. CONNECTIONS	B6	G 1 1/4"
9. BYPASS VALVE	0	no by-pass (housing inbuilt)
10. INDICATOR PORT OPTION	0	no indicator port
	Z	ports for absolute pressure gauge and differential clogging indicator both plugged with metal plug
11. COMPULSORY FIELD	000	Filtrec standard
12. CORROSION PROTECTION	S	standard (Filter head with no treatment)
13. OPTIONS	0	no options

ACCESSORIES

The accessories must be ordered separately

INDICATOR	MP0	pressure gauge rear connection, scale 0-16 bar
For other options see clogging indicators catalogue	MPC	pressure gauge rear connection, setting 3 bar, scale 0-10 bar
	MRC	pressure gauge radial connection, setting 3 bar, scale 0-10 bar
	VEXF2	differential visual electric 2,7 bar
	PF1	metal plug for indicator seat - FKM

PRESSURE DROP (Δp) INFORMATION FOR FILTER SIZING

The total Delta P through a filter assembly is given from Housing Δp + Element Δp ; this ideally should not exceed 1,0 bar. N.B. All the reported data have been obtained at our laboratory, according to specification ISO3968 with mineral oil having 32 cSt viscosity and density 0,875 Kg/dm³.

HOUSING PRESSURE DROP

The housing Δp is given by the curve of the considered model and port, in correspondence of the flow rate value.

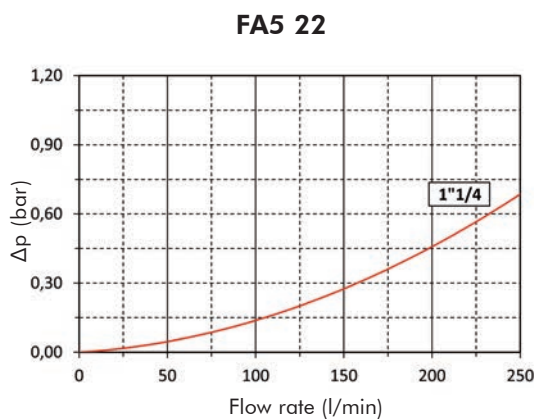

ELEMENT PRESSURE DROP

The element Δp (bar) is given by the flow rate (l/min) multiplied by the factor in the table here below corresponding to the selected media and divided by 1000. If the oil has a viscosity V_x different than 32 cSt a corrective factor $V_x/32$ must be applied.

Example: 100 l/min with A522G01V0/AB2 and oil viscosity 46 cSt $> 100 \times 5,8/1000 \times 46/32 = 0,83$ bar

	G01	G03	G06	G10	G25	GW40
A522	5,8	3,29	1,08	0,83	0,65	0,98

EXAMPLE OF TOTAL Δp CALCULATION

FA522G01V0AB2B60Z000S0 with 100 l/min and oil 46 cSt

Housing Δp 0,14 bar + element Δp 0,83 bar ($100 \times 5,8/1000 \times 46/32$) = total assembly Δp 0,97 bar

USER TIPS



- 1 FILTER HEAD
- 2 INDICATOR PORT
- 3 FIXING HOLES
- 4 FILTER CARTRIDGE
- 5 GASKET

CARTRIDGE TIGHTENING TORQUE

All models	1/2 turn
------------	----------

INDICATOR TIGHTENING TORQUE

Differential	50 Nm
Absolute	10 Nm

SPARE SEAL KIT

	FKM
FA5-2x	06.021.00411



WARNING

-  Make sure that Personal Protective Equipment (PPE) is worn during installation and maintenance operation.

DISPOSAL OF FILTER ELEMENT

-  The used filter elements and the filter parts dirty of oil or fuel are classified as "Dangerous waste material": they must be disposed according to the local laws by authorized Companies.



INSTALLATION

-  1. the IN and OUT ports must be connected to the hoses in the correct flow direction (an arrow shows on the filter head (1))
- 2. the filter housing should be preferably mounted with the cartridge (4) downward
- 3. secure to the frame the filter head (1) using the threaded fixing holes (3)
- 4. verify that no tension is present on the filter after mounting
- 5. enough space must be available for filter element cartridge replacement
- 6. the visual clogging indicator must be in a easily viewable position
- 7. when a electrical indicator is used, make sure that it is properly wired
-  8. never run the system with no filter element fitted
- 9. keep in stock a spare FILTREC filter element for timely replacement when required

OPERATION

-  1. the filter must work within the operating conditions of pressure, temperature and compatibility given in the first page of this data sheet
- 2. the filter element must be replaced as soon as the clogging indicator signals at working temperature (in cold start conditions, fluid temperature lower than 30°C, a false alarm can be given due to oil viscosity)
- 3. If no clogging indicator is mounted, replace the element according to the system manufacturer's recommendations

MAINTENANCE

-  1. make sure that the system is switched off and there is no residual pressure in the filter
- 2. unscrew the filter cartridge (4) by turning it anti-clockwise and remove it. Check the condition of the gasket located at the end of the threaded spigot; replace it if necessary
- 3. fit a new FILTREC cartridge element (4), verifying the part number, particularly concerning the micron rating
- 4. ensure that the head mounting face is clean
-  5. lubricate the gasket of the replacement cartridge and the thread prior to assembly
- 6. spin on the new cartridge until it reaches the mounting face and tighten for 1/2 turn.

