

Valvola direzionale automatica - luce 10
Automatic directional valve - NG10

mod. VAD-F-C5

Corpo in ghisa
Cast iron body

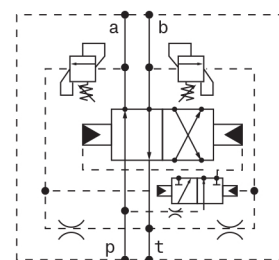
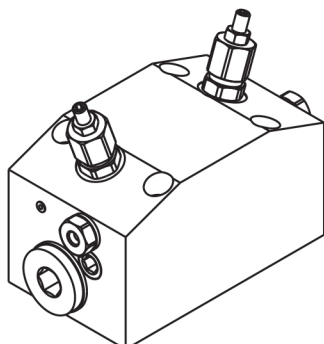

Portata massima Max flow	70 l/min 18.5 gpm
Pressione massima Max pressure	250 bar 3600 psi
Taratura standard Standard setting	180 bar 2600 psi
Campo di taratura Adjustment pressure range	40 ÷ 250 bar 580 ÷ 3600 psi
Portata minima Min flow	6 l/min 1.6 gpm

Dati e tarature ottenuti usando olio con viscosità 30 cSt a 50°C
Performances and calibrations are carried out by using hydraulic oil with 30 cSt viscosity at 50°C

Viscosità consigliate Recommended viscosity	10 ÷ 420 cSt
Temperature di lavoro Working temperature	-20 ÷ +90 °C
Filtrazione assoluta Absolute filtration	25 µ

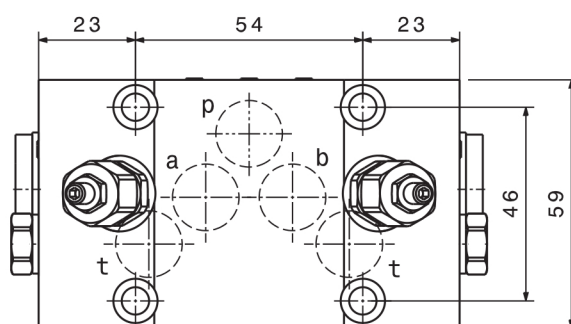
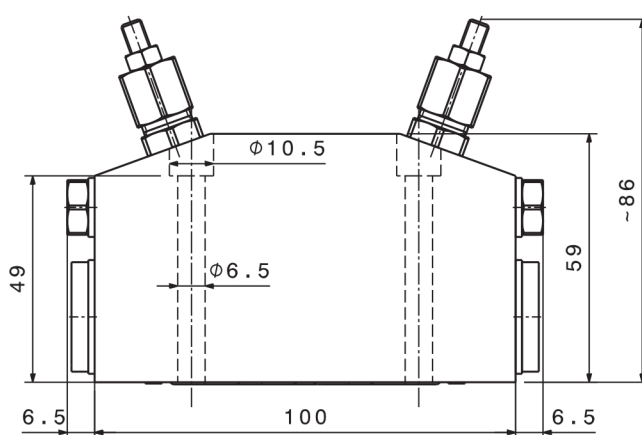

Sigla di ordinazione / Ordering code

VAD-F-C5

Modello
Type