

FFS16/80T

Portable Hose Crimping Machine Max 1" 2-SN (DN25, -16)

The FFS16/80T is ideal for on-site hose repairs as it will help to repair hoses with uneasy access. The magnetic head of the FFS16/80T also allows you to position the head at an ideal height or safely position the head onto the boom of a machine where a hose needs to be repaired.

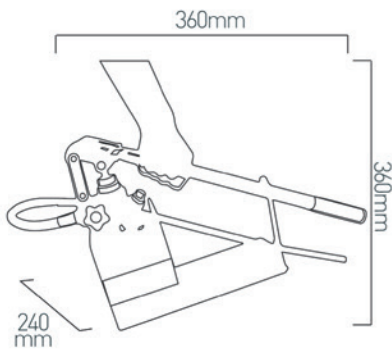

Crimps up to 1" Hose

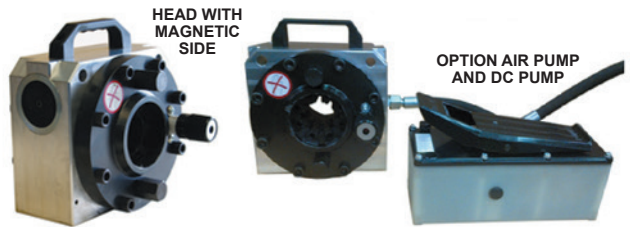

PRODUCT FEATURES

- SPLITTED HEAD AND PUMP CONCEPT
- HEAD WITH MAGNET
- IDEAL FOR ON SITE HOSE REPAIRS

TECHNICAL SPECIFICATION

Capacity : For hydraulic hose crimping and intermittent use	2-SN: 1" (DN25; -16) 4-SP: 1/2" (DN13; -10) Limit for assembly with 2 x 90° elbows: max 1/2" (DN13)
Hand Pump	Double Stage 25cm3 + 5cm3, Max 320 Bar
Radial Crimp force	80 tons
Die opening	Ø Die. + 20mm
Opening without dies	56 mm
Head Dimensions	Width: 240mm Depth: 130mm Height: 240mm
Pump Dimensions	Width: 360mm Depth: 130mm Height: 360mm
Net weight (with oil, without dies)	20 Kg for one magnetic head (NKS16.1) 9 Kg for hand pump support with drawer (NKS16-HP1)
Packing details (for transport purposes)	Wooden crate conform to ISPM15 Crate size: 26x41x48cms Gross weight (with 6 sets of dies): 35 Kgs

PRICE FOR MACHINE

1" DIE PART OF CRIMPER				
SELECT DIES FROM TABLE BELOW				
PART NO.	DIE SIZE Ø	HOSE SIZE	NETT. PRICE	
			£ STERLING	€ EUROS
FF60DIES-10	10	*BY MAN		
FF61DIES-12	12	*BY MAN		
FF62DIES-15	15	*BY MAN		
FF63DIES-18	18	**1/4"		
FF64DIES-21	21	**3/8"		
FF65DIES-24	24	**1/2"		
FF66DIES-27	27	**5/8"		
FF67DIES-30	30	**3/4"		
FF67DIES-30	30	3/4"		

**The hose sizes stating hose size in table above are for use with Flowfits Vincke Hydraulic Hose!

*BY MAN = By Manufacturer, Hose size determined by hose manufacturers crimping data- Please check with YOUR hose supplier!