

CILINDROS D.E. VÁSTAGO LISO [8600]

D.A. cylinders with plain rod [8600] / Vérins D.E. avec tige lisse [8600]

D.W. Hydraulikzylinder ohne Gewinde an der Kolbenstange (Glatt) [8600]

03

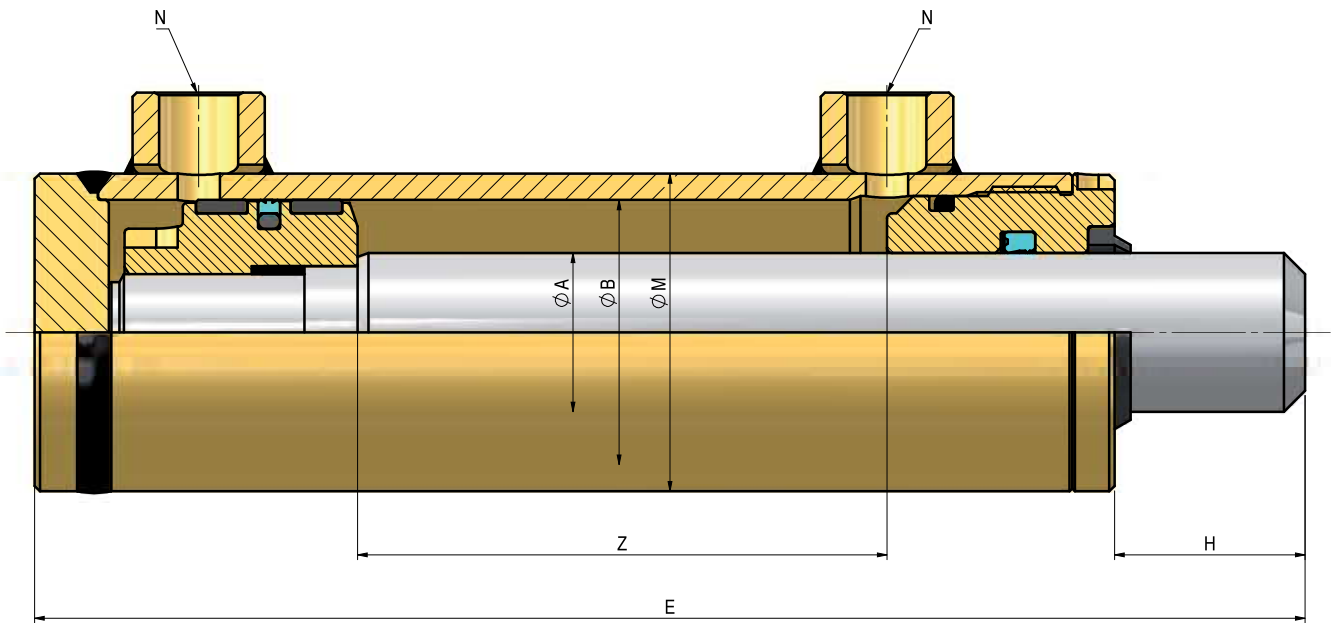

SERIE 8600 / SERIES 8600 / SÉRIE 8600 / SERIE 8600

REF.	ØA	ØB	ØM	E	H	N BSP
8600/Z	20	32	40	130+Z	23	1/4"G
8601/Z	22	40	50	120+Z	23	3/8"G
8602/Z	25	40	50	120+Z	23	3/8"G
8603/Z	28	40	50	120+Z	23	3/8"G
8604/Z	25	50	60	130+Z	26	3/8"G
8605/Z	28	50	60	130+Z	26	3/8"G
8606/Z	30	50	60	130+Z	26	3/8"G
8607/Z	36	50	60	130+Z	26	3/8"G
8608/Z	30	60	70	130+Z	24	3/8"G
8609/Z	35	60	70	130+Z	24	3/8"G
8610/Z	40	60	70	130+Z	24	3/8"G
8611/Z	36	63	75	130+Z	24	3/8"G
8612/Z	40	63	75	130+Z	24	3/8"G
8613/Z	45	63	75	130+Z	24	3/8"G
8614/Z	35	70	80	140+Z	26	3/8"G
8615/Z	40	70	80	140+Z	26	3/8"G
8616/Z	45	70	80	140+Z	26	3/8"G
8617/Z	36	80	90	150+Z	24	3/8"G
8618/Z	40	80	90	150+Z	24	3/8"G
8619/Z	45	80	90	150+Z	24	3/8"G
8620/Z	50	80	90	150+Z	24	3/8"G
8621/Z	56	80	90	150+Z	24	3/8"G
8622/Z	45	100	115	170+Z	32	1/2"G
8623/Z	50	100	115	170+Z	32	1/2"G
8624/Z	56	100	115	170+Z	32	1/2"G
8625/Z	60	100	115	170+Z	32	1/2"G
8626/Z	70	100	115	170+Z	32	1/2"G
8627/Z	70	125	145	230+Z	35	3/4"G
8628/Z	90	125	145	230+Z	35	3/4"G
8629/Z	80	140	160	262+Z	37	3/4"G
8630/Z	90	160	180	280+Z	42	1"G
8631/Z	110	160	180	280+Z	42	1"G
8632/Z	110	200	230	330+Z	52	1"G

Z = carrera (a definir por el cliente) / Z = stroke (to be defined by customer)
 Z = course (à définir par le client) / Z = Hub (vom Kunden festzulegen)

