

CILINDROS D.E. BRIDA DELANTERA [8000]

Front-bridle D.A. Cylinders [8000] / Vérins D.E. avec bride avant [8000]
 D.W. Hydraulikzylinder mit Kopfflansch [8000]

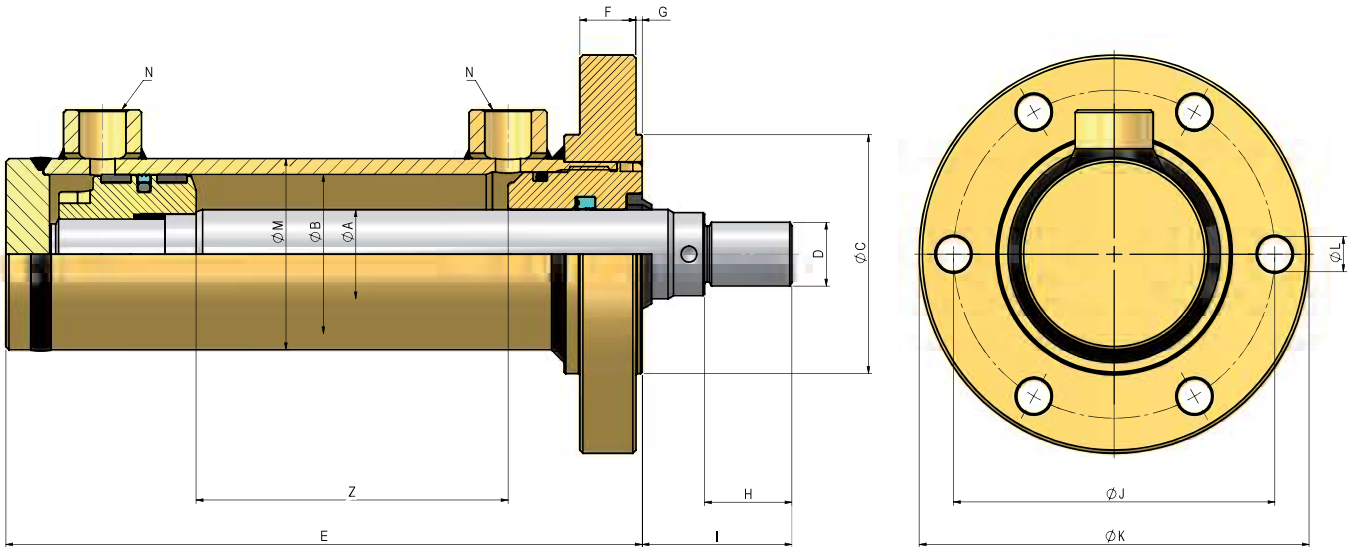

SERIE 8000 / SERIES 8000 / SÉRIE 8000 / SERIE 8000

REF.	ØA	ØB	E	C	D	F	G	H	I	J	K	L	M	N BSP
8000/Z	20	32	107+Z	52	M14x1.5	15	2	18	35	67	80	7	42	1/4
8001/Z	22	40	97+Z	60	M16x1.5	15	2	22	40	82	100	9	50	3/8
8002/Z	25	40	97+Z	60	M16x1.5	15	2	22	40	82	100	9	50	3/8
8003/Z	28	40	97+Z	60	M16x1.5	15	2	22	40	82	100	9	50	3/8
8004/Z	25	50	104+Z	75	M20x1.5	18	2	28	48	103	125	11	60	3/8
8005/Z	28	50	104+Z	75	M20x1.5	18	2	28	48	103	125	11	60	3/8
8006/Z	30	50	104+Z	75	M20x1.5	18	2	28	48	103	125	11	60	3/8
8007/Z	36	50	104+Z	75	M20x1.5	18	2	28	48	103	125	11	60	3/8
8008/Z	30	60	106+Z	90	M27x2	20	2	36	58	120	145	13	70	3/8
8009/Z	35	60	106+Z	90	M27x2	20	2	36	58	120	145	13	70	3/8
8010/Z	40	60	106+Z	90	M27x2	20	2	36	58	120	145	13	70	3/8
8011/Z	36	63	106+Z	90	M27x2	20	2	36	58	120	145	13	75	3/8
8012/Z	40	63	106+Z	90	M27x2	20	2	36	58	120	145	13	75	3/8
8013/Z	45	63	106+Z	90	M27x2	20	2	36	58	120	145	13	75	3/8
8014/Z	35	70	114+Z	100	M27x2	24	2	36	58	130	160	15	85	3/8
8015/Z	40	70	114+Z	100	M27x2	24	2	36	58	130	160	15	85	3/8
8016/Z	45	70	114+Z	100	M27x2	24	2	36	58	130	160	15	85	3/8
8017/Z	36	80	126+Z	110	M33x2	28	2	45	68	142	170	15	95	3/8
8018/Z	40	80	126+Z	110	M33x2	28	2	45	68	142	170	15	95	3/8
8019/Z	45	80	126+Z	110	M33x2	28	2	45	68	142	170	15	95	3/8
8020/Z	50	80	126+Z	110	M33x2	28	2	45	68	142	170	15	95	3/8
8021/Z	56	80	126+Z	110	M33x2	28	2	45	68	142	170	15	95	3/8
8022/Z	45	100	138+Z	135	M42x2	30	3	56	85	170	202	17	115	1/2
8023/Z	50	100	138+Z	135	M42x2	30	3	56	85	170	202	17	115	1/2
8024/Z	56	100	138+Z	135	M42x2	30	3	56	85	170	202	17	115	1/2
8025/Z	60	100	138+Z	135	M42x2	30	3	56	85	170	202	17	115	1/2
8026/Z	70	100	138+Z	135	M42x2	30	3	56	85	170	202	17	115	1/2
8027/Z	70	125	210+Z	170	M48x2	40	3	63	92	210	250	21	145	3/4
8028/Z	90	125	210+Z	170	M48x2	40	3	63	92	210	250	21	145	3/4
8029/Z	80	140	225+Z	190	M64x3	40	3	85	120	230	280	21	160	3/4
8030/Z	90	160	238+Z	215	M80x3	54	3	95	130	270	320	29	180	1
8031/Z	110	160	238+Z	215	M80x3	54	3	95	130	270	320	29	180	1
8032/Z	110	200	278+Z	270	M80x3	65	3	95	130	330	385	32	230	1

Z = carrera (a definir por el cliente) / Z = stroke (to be defined by customer)

Z = course (à définir par le client) / Z = Hub (vom Kunden festzulegen)