

# NEW

## 2SPW

Cast Iron Gear Pump



# start POWER



 **walvoil**  
FLUID POWER E|MOTION

A member of



# 2SPW

## Cast Iron Gear Pump



Walvoil presents the new range of 2SPW Cast Iron Pumps. These pumps are particularly suitable for all applications where traditional aluminum pumps are used at the limit of their performance; eg. for installation on mobile equipment intended for heavy duty operating cycles, where pressures or mechanical stresses are typically higher.

Its modular construction allows the same versatility of the Group 2 series with aluminum body, while maintaining the possible configurations in terms of flanges, shafts and integrated valves.

- Long life expectancy
- High efficiencies
- High pressure limits
- Reduced number of components
- Reduced overall dimension

GENERAL WORKING CONDITIONS		
<b>Displacement</b>		from 14 to 31.5 cm <sup>3</sup> /rev from 0.85 to 1.92 in <sup>3</sup> /rev
<b>Max continuous pressure</b>	up to	250 bar - 3600 psi
<b>Fluid</b>		hydraulic mineral oil-based
<b>Fluid temperature range</b>	with NBR (buna N) seals	from -20 to +80 °C from -4 to +176 °F
	with FPM (viton) seals	from -20 to +100 °C from -4 to +212 °F
<b>Viscosity</b>	Recommended	from 15 to 92 mm <sup>2</sup> /s (cSt)
	Permitted for starting	2000 mm <sup>2</sup> /s (cSt)
<b>Max level of contamination</b>	Recommended for operating pressure > 150 bar (2150 psi)	20/18/15 ISO 4406 class 9 (NAS 1638)
	Recommended for operating pressure < 150 bar (2150 psi)	21/18/15 ISO 4406 class 10 (NAS 1638)

### Technical data

GROUP 2SPW	Displacement		Max continuous pressure		Max Intermittent Pressure		Max Peak Pressure		Max rotation speed rpm
	cm <sup>3</sup> /rev	in <sup>3</sup> /rev	bar	psi	bar	psi	bar	psi	
<b>2SPW 140</b>	14.0	0.85	250	3,600	280	4,060	300	4,350	3500
<b>2SPW 160</b>	16.5	1.01	250	3,600	280	4,060	300	4,350	3500
<b>2SPW 190</b>	19.5	1.19	250	3,600	280	4,060	300	4,350	3500
<b>2SPW 220</b>	22.5	1.37	250	3,600	270	3,900	300	4,350	3500
<b>2SPW 260</b>	26.0	1.59	230	3,330	250	3,600	280	4,060	3000
<b>2SPW 310</b>	31.5	1.92	200	2,900	240	3,480	250	3,600	2800

# NEW

## Dimensions

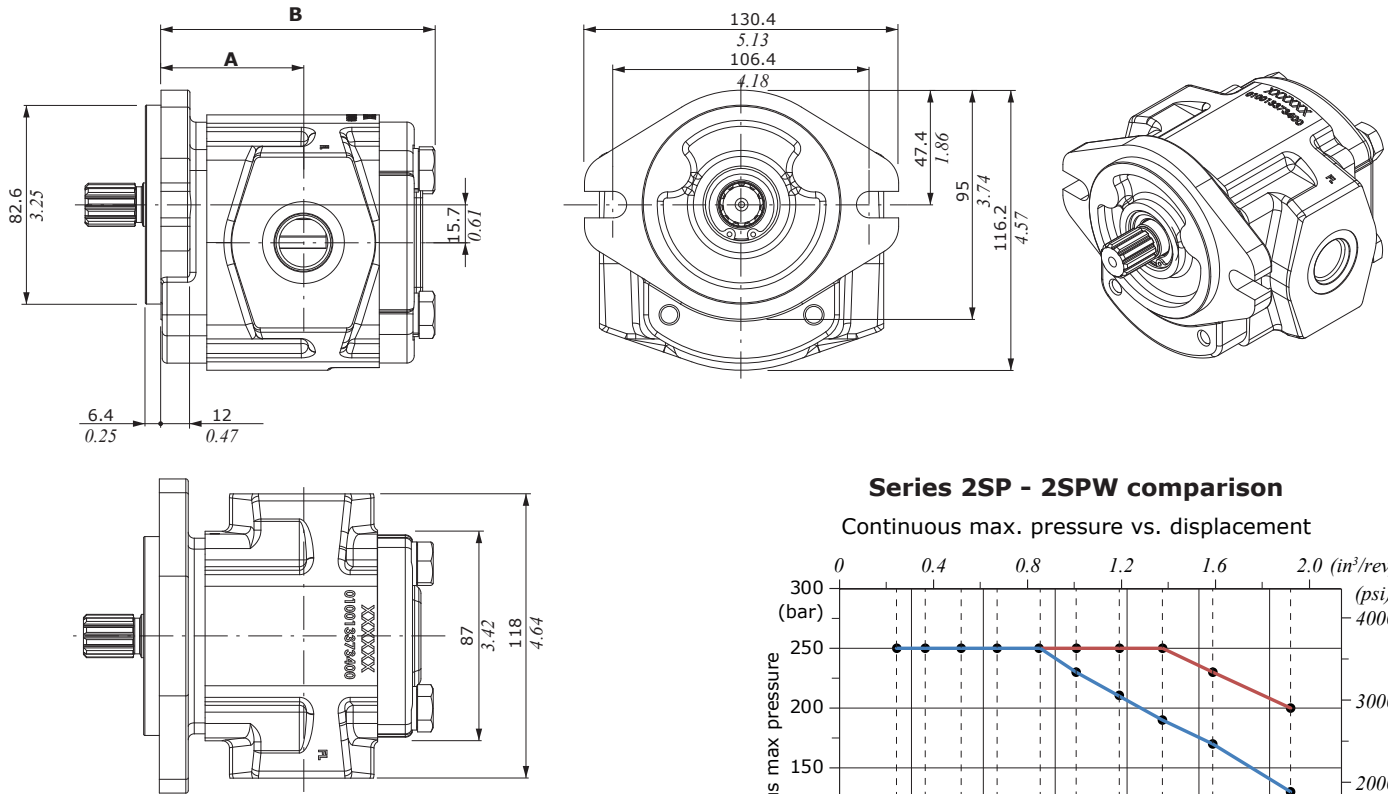

### Series 2SP - 2SPW comparison

Continuous max. pressure vs. displacement

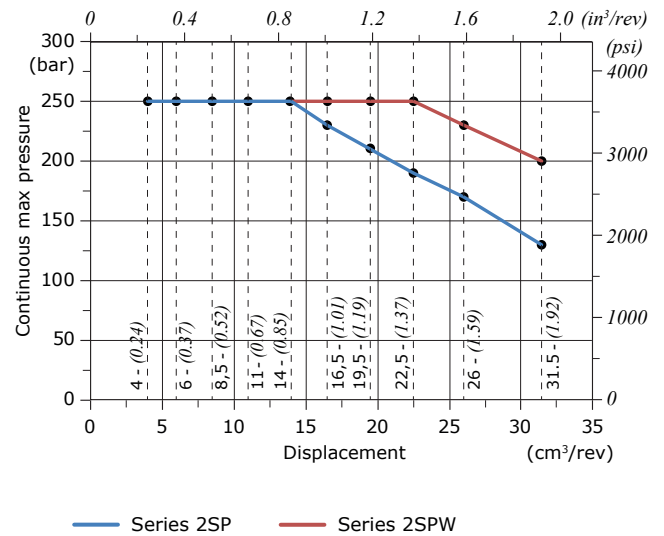

GROUP 2SPW	A		B	
	mm	in	mm	in
2SPW 140	54.9	2.161	109.5	4.311
2SPW 160	59.1	2.326	113.7	4.476
2SPW 190	64.1	2.524	118.7	4.673
2SPW 220	68.1	2.681	123.7	4.870
2SPW 260	67.9	2.673	129.5	5.098
2SPW 310	68.3	2.689	137.9	5.429

GROUP 2SPW	Ports Threading									
	BSP					UN-UNF				
	IN	OUT	IN*	OUT*	DRAIN*	IN	OUT	IN*	OUT*	DRAIN*
140	G3/4	G1/2	G3/4	G3/4	G1/4	SAE12	SAE10	SAE12	SAE12	SAE6
160	G3/4	G1/2	G3/4	G3/4	G1/4	SAE12	SAE10	SAE12	SAE12	SAE6
190	G3/4	G1/2	G3/4	G3/4	G1/4	SAE12	SAE10	SAE12	SAE12	SAE6
220	G1	G1/2	G3/4	G3/4	G1/4	SAE16	SAE10	SAE12	SAE12	SAE6
260	G1	G1/2	G3/4	G3/4	G1/4	SAE16	SAE10	SAE12	SAE12	SAE6
310	G1	G1/2	G3/4	G3/4	G1/4	SAE16	SAE10	SAE12	SAE12	SAE6

NOTE(\*): Only for reversible motor/pump configuration





## Dimensions: configuration with priority valve

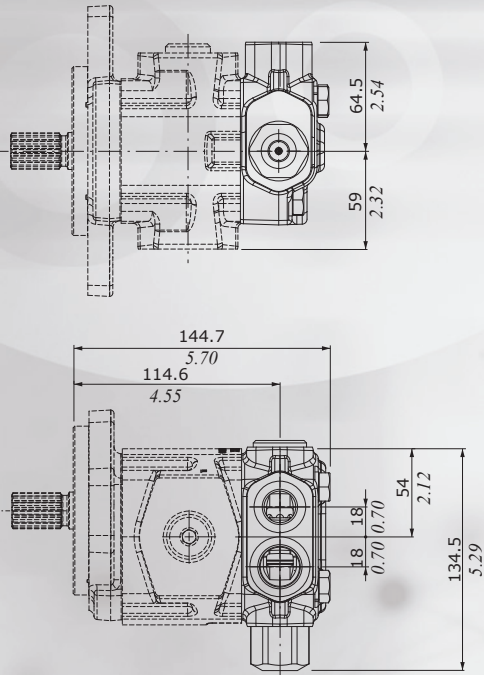

## Configuration with priority valve built in the back cover of the pump

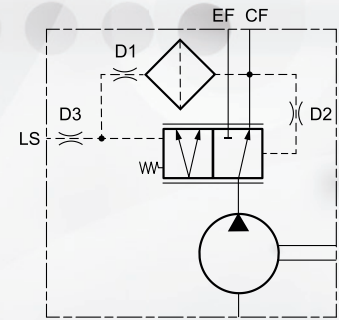
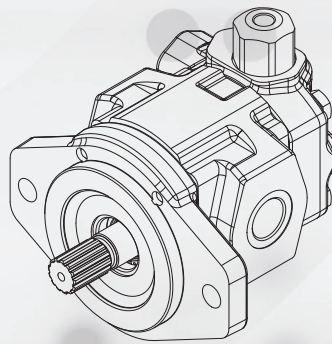

## Combinations available with cast iron flanges

GROUP 2SPW		Shaft type											
		10 Tapered 1:8	11 Tapered 1:5	12 EUR Parallel shaft	13 SAEA Parallel shaft	14 SAEA 9T splined	15 DIN5482 9T splined (26/24)	16 DIN5482 9T splined (20)	40 SAE 10T splined (52)	41 SAE 10T splined (37.5)	42 SAEA 11T splined (55.6)	43 SAEA 11T splined (31.5)	44 SAEA 11T splined (13.5)
EUR		◆	●	◆	●	●	●						
SAEA		●	●	●	◆	◆	●	●	●	●	●	●	●
SAEB		●	●	●	◆	◆	●	●	●	●	●	●	●

◆ = STANDARD COMBINATION  
● = AVAILABLE COMBINATION

**walvoil**  
FLUID POWER EMOTION

**walvoil**

**hydro control**

**Caltech**  
ELECTRONICS

D1WGCM01A - 3<sup>rd</sup> edition October 2018

Walvoil S.P.A. • 42124 Reggio Emilia • Italy • Via Adige, 13/D • Tel.+39.0522.932411 • Fax +39.0522.300984  
www.walvoil.com

